

Document Control Input	
Document #	027
Project File #	401.2
Subject:	
Keyword:	
Action Req'd:	Y N
Action By:	
Due Date:	

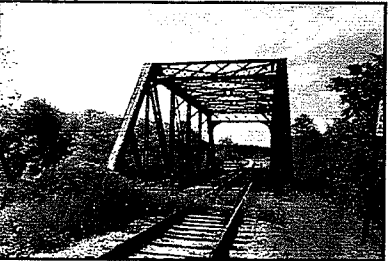
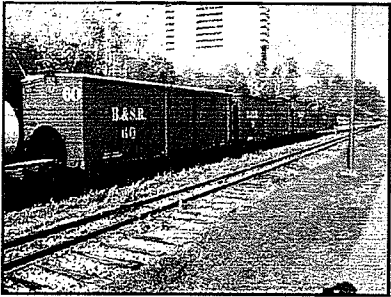
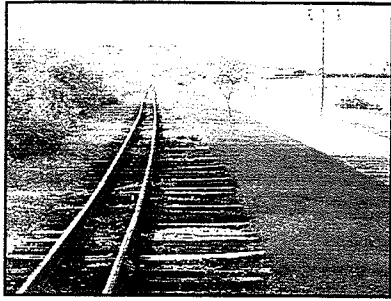

COST FEASIBILITY STUDY

for

Portland Commuter Rail Study

Portland, Maine
to
Brunswick & Auburn, Maine

PIN 9503.20

December 14, 2005

HNTB



COST FEASIBILITY STUDY

Portland Commuter Rail Study

TABLE OF CONTENTS

1. Introduction

2. Summary of Study Area

3. Summary of Link Costs

4. Rail Corridor Costs

5. Station Platform & Additional Siding Costs

Appendix

- **Breakdown of Link Costs**
- **Underwater Inspection Report**

1. INTRODUCTION

This Feasibility Study provides a summary of preliminary construction costs for track and related improvements necessary for commuter rail service from Portland to Brunswick and Auburn.

The information in this study will be incorporated into a "Portland North Alternatives Review" Report being developed by KKO and Associates for NNEPRA, which will evaluate costs, ridership and revenue projections for passenger rail service extension north of Portland.

This cost feasibility study considers cost for track, signal, and bridge improvements associated with the rail, highway improvements at highway-rail grade crossings, warning system upgrade work at highway-rail crossings, railroad train control signal work, new rail connection in Yarmouth (Yarmouth Junction), and one 3 mile passing siding.

As part of this study, an evaluation of the existing Portland RR trestle was completed. The evaluation included structural, underwater, mechanical and electrical inspection of the swing span and structural, underwater, track and signal inspection of the timber trestles approaching the swing span. The inspection findings, analysis and rehabilitation costs of the Portland RR trestle are included in this report.

Costs for train station platforms and additional sidings requested by KKO and Associates are also included in this assignment and can be found in Section 5.

2. SUMMARY OF STUDY AREA

The study area extends from Portland, Maine north to Brunswick and west to Auburn, Maine. North of Portland, the study limits follow the active railroad lines of St. Lawrence & Atlantic and Guilford Rail Systems. The study limits are comprised of Study Nodes and Links as described in detail below.

Reference Maps have been provided at the back of this Section for further clarification.

Study Nodes

Eleven (11) junctions or terminal points have been identified for this study. These locations represent existing train stations, proposed train stations, existing track junctions or proposed track junctions. A summary of the Nodes is provided below.

NODE	DESCRIPTION
N1	Portland Waterfront - Ocean Gateway, Proposed Hancock Street Extension
N2	Portland RR Trestle - South End
N3	Portland RR Trestle - North End
N4	Portland Transportation Center, Amtrak Terminal
N5	Guilford and Union Branch Junction
N6	Proposed Bayside Station, Marginal Way & Franklin Arterial
N7	Proposed Back Cove Bridge – South End
N8	Proposed Yarmouth Station - I-295 Exit 15
N9	Yarmouth Junction, Guilford and St. Lawrence & Atlantic
N10	Proposed Brunswick Station – Main Street
N11	Proposed Auburn Station, Auburn Intermodal Facility & Airport

Study Links

Eleven (11) Links or connectors have been identified for this study. These Links are comprised of portions of track owned or used by St. Lawrence & Atlantic (SLR), Maine Narrow Gauge (MNGRR), Guilford Rail System (GRS) and Maine Eastern Railroad (MERR). A summary of the Links is provided below.

LINK	NODES	DESCRIPTION	LENGTH
L1	N1-N2	portland waterfront to portland RR trestle south	7000 ft (1.3mi)
L2	N2-N3	portland RR trestle	1550 ft (0.3mi)
L3	N4-N5	proposed portland wye	2100 ft (0.4mi)
L4	N5-N6	proposed union branch, south of franklin arterial	6900 ft (1.3mi)

L5	N6-N7	proposed union branch, north of franklin arterial	3300 ft (0.6mi)
L6	N7-N3	proposed back cove bridge	1700 ft (0.3mi)
L7	N3-N8	portland RR trestle to proposed yarmouth station @ I295, exit15	44900 ft (8.5mi)
L8	N8-N9	proposed yarmouth station @ I295, exit15 to yarmouth junction	10500 ft (2.0mi)
L9	N9-N10	yarmouth junction to proposed brunswick station, main street	75000 ft (14.2mi)
L10	N9-N11	yarmouth junction to proposed auburn station at intermodal facility, airport	96000 ft (18.2mi)
L11	N7-N2	proposed union branch connection to portland waterfront RR	2000 ft (0.4mi)

See included Reference Maps to actual locations of Links and Nodes.

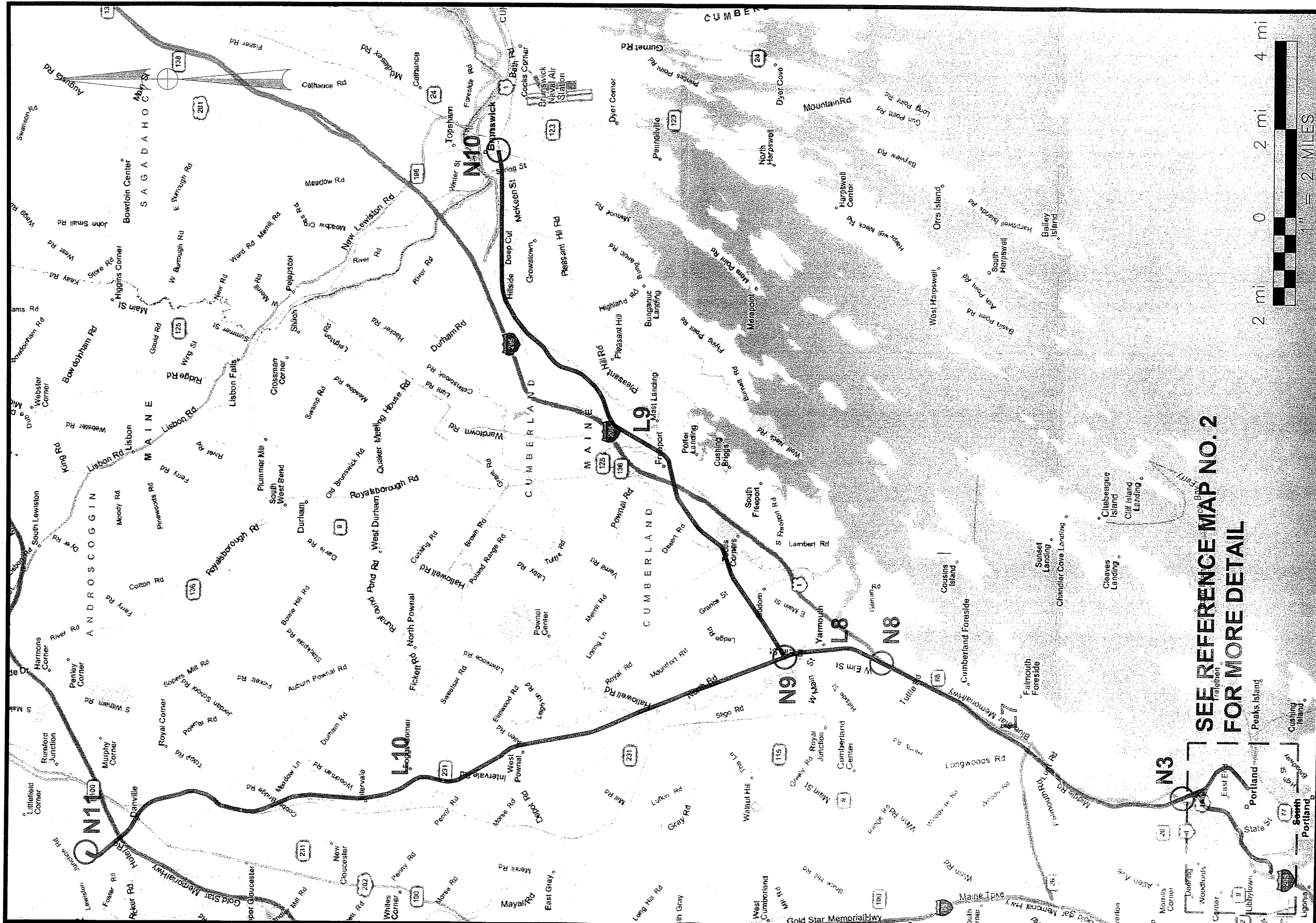

**SEE REFERENCE MAP NO. 2
FOR MORE DETAIL**

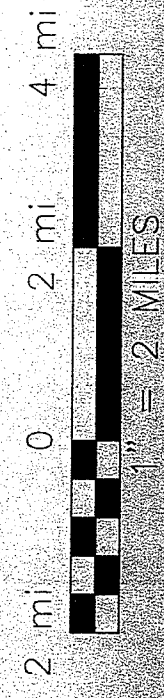

HNTB		REFERENCE MAP NO. 1	
		PIN 9503.41	
PROJ. MANAGER	DESIGN-DETAILED	DATE	
	CHECKED-REVIEWED		
PORTLAND COMMUTER RAIL STUDY REFERENCE MAP NO. 1			
SHEET NUMBER		1	
OF 2			

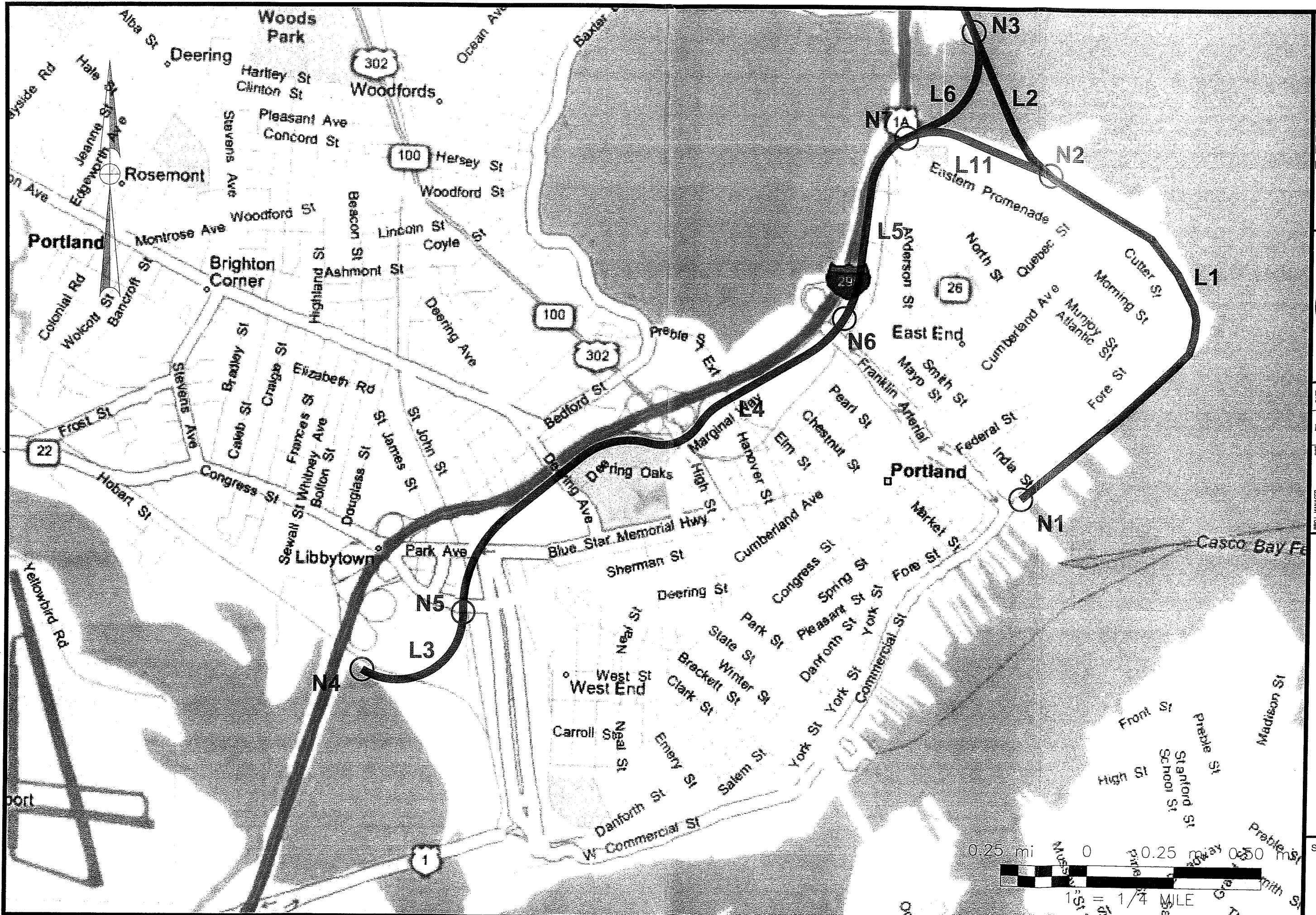

PROJ. MANAGER	DATE
DESIGN-DETAILED	
CHECKED-REVIEWED	
DRAWN	
BY	
DATE	

3. SUMMARY OF LINK COSTS

Preliminary construction cost estimates for each of the Links within the Study area were developed for this report. The chart below provides a summary of the link costs.

LINK	DESCRIPTION	TOTAL
L1	Portland Waterfront to Portland RR Trestle South	\$4,890,000.00
L2	Portland RR Trestle	\$8,880,000.00
L3	Portland Wye Junction	\$4,540,000.00
L4	Proposed Union Branch, South of Franklin Arterial	\$4,760,000.00
L5	Proposed Union Branch, North of Franklin Arterial	\$2,160,000.00
L6	Proposed Back Cove Bridge	\$8,860,000.00
L7	SLR, Portland RR Trestle to Proposed Yarmouth Station @ I295, Exit 15	\$17,590,000.00
L8	SLR, Proposed Yarmouth Station @ I295, Exit 15 to Yarmouth Junction	\$4,370,000.00
L9	Guilford, Yarmouth Junction to Proposed Brunswick Station, Main Street	\$19,170,000.00
L10	SLR, Yarmouth Junction to Auburn Intermodal Facility	\$31,380,000.00
L11	Proposed Union Branch Extension to Portland Waterfront RR	\$2,090,000.00

The following general assumptions have been made regarding this study:

1. All tracks are signalized for the length of the project. All highway-rail grade crossings are equipped with Constant Warning Time predictors, except for the MNGRR track.
2. Costs include improvements to at-grade roadway crossings. A separate funding source may be used for improvements to at-grade roadway crossings.
3. Continuous welded rail to be used on RR mainline except on bridges. Existing rail on Link 9, Guilford line, is 115 lb jointed rail, installed in the 1980's. If negotiated through Guilford, it maybe feasible that this existing rail could be reused on the project, however this is not accounted for in this report.
4. Limits of future MNGRR operations to remain on Link 1 only. Cost estimates for other links do not account for MNGRR service.
5. This report assumes the Federal Railroad Administration (FRA) will permit MNGRR operations on an active commuter rail line. FRA waiver is required for dual mode of operation. It is assumed that operations will be time separated and FRA will grant waiver.
6. The costs in this section do not include layover facilities, train stations, other facilities, engineering, inspection, or land acquisition. Train station platform costs discussed in Section 4.

7. The costs are construction estimates only. Maintenance, equipment and operation costs not included.
8. Environmental testing/services not included.
9. Contingency costs have been assigned as follows; 5% contingency to final designed sections, 10% to preliminary designed sections, and 15% to sections where no design has occurred.
10. Structures over the RR excluded from estimates.
11. A dispatching system is required to control sidings and interlockings. Dispatching system cost to be \$275,000, not included in Link costs below.

The remaining portion of this section provides specific costs, details and assumptions made for each Link during the analysis.

Link 1 – Portland Waterfront to Portland RR Trestle South

This MaineDOT owned section of track is currently active with the Maine Narrow Gauge train service (MNGRR). It's approximately 1.3 miles in length and the existing infrastructure includes 2 ft. gauge track only.

The required action for this link includes full replacement of rail, tie, and ballast on a modified alignment. Improvements to several roadway and bike path crossings are required along this section. The repair of undermined sections of the existing sea wall is included.

The costs for Link 1 are summarized below. See Appendix for detailed cost estimate.

DESCRIPTION	TOTAL
Track Improvement Costs	\$1,721,906.40
Track Improvement Costs for Narrow Gauge Service	\$896,310.35
Signal Improvement Costs	\$1,279,306.00
Roadway, Drainage, Wall Repair Costs	\$350,500.00
15% Contingency	\$637,203.41

TOTAL(ROUNDED) : \$4,890,000.00

Link 1 Assumptions

1. Rail crossing estimates are for average road width of 30 feet and include pavement markings, additional crossing effort noted in Signal Pay Items
2. Unit prices gathered from latest DOT Bid Price Averages or previous unit prices adjusted for 3.5% annual inflation.

3. Adjacent tracks of MNGRR will be maintained in solid class 1 condition and that a separation barrier is not required. MNGRR will have all turnouts on the west side of main line.
4. MNGRR will be time separated from commuter rail traffic.
5. MNGRR shop switch turnout can be relocated from mainline to yard lead. Northerly MNGRR runaround relocated between Cutter Street and Bike Path crossings on tangent.
6. MNGRR 3rd rail cost could be reduced if materials removed from Brunswick Branch are reused.
7. Recommend that new track alignment be designed prior to track reconfiguration along Portland Gateway Phase 1.
8. Maximum design speed of 30 mph anticipated on this link. Partial bike path realignment recommended along this link to increase separation from track, not included in this estimate.
9. MNGRR operations will not be governed by standard gauge signal system.
10. MNGRR hand throw switches on the main track will not include electric locks but will be point protected for standard gauge signal system.
11. MNGRR crossings will be activated by overlay track circuits. Assumes the MNGRR trains are capable of shunting.
12. MNGRR maximum authorized speed is 15 mph.

Link 2 – Portland RR Trestle

This MaineDOT owned section of track is currently inactive. The bridge has been out of service since a fire damaged the south approach trestle, we assume to have occurred in the 1984. In an effort to activate this bridge for commuter rail service, HNTB conducted a detailed inspection, evaluation and analysis of the structure.

The evaluation included structural, underwater, track and signal inspection of the timber trestles approaching the swing span and structural, underwater, mechanical and electrical inspection of the swing span. The inspection findings and resulting analysis is discussed in the following sections.

❖ Timber Trestle

A field evaluation of the timber trestle was conducted the week of October 24, 2005. As part of the evaluation, field measurements were taken of timber and pile member sizes, framing arrangement, pile pattern and bent spacing. In addition to a general condition assessment of the entire length of trestle, an in-depth inspection was conducted of approximately 100 ft of timber trestle. This section was located along the north approach trestle, closest to the movable swing span. Based on data collected from the field, rating calculations were performed in accordance with Chapter 7, Section 2.10 of the American Railway

Engineering and Maintenance of Way Association, Manual for Railway Engineering, from here on referred to as AREMA. Existing bridge records provided by the Department generally did not provide information regarding the timber trestle approaches.

- North Approach Trestle

The north approach trestle was constructed of six (6) 10 x 18 inch heavy timbers supporting 10 x 10 inch timber ties at 16 inch center to center spacing. Stringers were positioned in two sets of 3 centered under the track rails in a typical AREMA trestle arrangement. Total length of the north trestle was found to be approximately 750 feet. A maintenance walk with railing is located along the west side of the trestle. Substructure consisted of pile bents typically spaced at 12 feet on center. Cap beams were found to have minimum dimensions of 12 x 14 inches. Bents were typical braced with horizontal and diagonal 3 x 10 inch timbers on each side. Minimum pile diameter was found to be 12 inches with a majority of the bents consisting of 6 piles with the outer piles battered. The thirteen (13) bents located closest to the swing span were constructed of 8 piles with the outer two piles (4 per bent) battered. The additional batter piles appear to be for transverse stability only as they do not extend up to the bent cap, but fastened laterally to adjacent batter piles. All timber dimension referred to in this summary are undressed unless otherwise noted.

Field evaluation found the stringers to be in general fair to good condition. A majority of steel bands that bound the timber groups have failed. Bridge timber (ties) were found to be in fair condition. A dapping pattern on the tie sides indicates the stringer arrangement was originally similar to that of south approach trestle (see description below) and later reconstructed to their current state. At that time the ties were rotated 90 degrees. For reliable commuter rail service it was assumed that timbers (ties) would have to be replaced in their entirety. Pile bents were found to be in fair to poor condition with some ice damage and splits. Splits generally occurred at the location of the horizontal brace connections. A dive inspection indicated evidence of marine borer activity (see appendix for complete dive inspection report). Some of the outer batter piles at the 8 pile bents are wild having become unfastened from their adjacent pile. Horizontal and diagonal bracing was found to be in poor condition and will require complete replacement along the entire length of the trestle.

All timbers and piles were assumed to be southern yellow pine. Because the actual grade is unknown, permissible unit stresses were based on the recommendations of AREMA Chapter 7, Article 2.10.14d. Based on these requirements, the north trestle stringers were found to have a rating of Cooper E65 for regularly assigned equipment or locomotives. Pile bents were found to have a somewhat lower minimum rating of E60. This is primarily due to the large (± 30 feet) unsupported pile lengths found in deeper water adjacent to the navigation channel.

Rehabilitation of the north trestle is assumed to consist of removal and replacement of all bridge timber ties, timber maintenance walk and safety rail; select replacement of decayed stringers, bent caps and piles; and complete replacement of bent bracing timbers. To attain a Cooper E72 rating, the stringers will be reset with the addition of two 10 x 18" stringers arranged in two (2) sets of four (4) stringers centered under the track rails. Piles will be added to the bents in deeper water adjacent to the movable swing span in order to relieve loads on this section and increase the rating to E72.

- South Approach Trestle

The framing of the south approach trestle is non-traditional consisting of three (3) sets of two (2) 10 x 16 inch timbers. There is ± 4 inch clear space between the two timbers and each set is spaced at approximately 3'-6" on center. The center of the stringer pattern is coincidental with the centerline of track. Tie timbers were found to be 10 x 10 inches similar to the north trestle however were spaced at 14 inches on center rather than 16 inches. The total length of the south trestle was measured to be 580 ft. All other aspects of trestle including pile pattern, bent construction, bracing and maintenance walk were similar to the north trestle except that bent spacing is reduced approaching the navigation channel presumably due to the increased unsupported length and corresponding reduction in allowable pile load.

A large section (± 400 feet) of the south trestle located adjacent to the movable swing span was damage by fire with much of the section, a complete lose. The remaining portions of south trestle were found to be in condition similar to that of the north trestle. The less efficient stringer framing results in a calculated load rating of E48 for regularly assigned equipment or locomotives.

Rehabilitation of the south trestle is assumed to be similar to the north trestle except that additional stringers would match the existing 10 x 16 inch timbers and sections of the most severe fire damage would require complete replacement in-kind.

- ❖ **Swing Span**

- History

- The Back Cove Swing Bridge carried a single track of the Atlantic and St. Lawrence (later renamed the Grand Trunk and later Canadian National) Railroad over the Back Cove in Portland, Maine. The existing bridge was constructed in 1912 by the Pennsylvania Steel Company, Steelton, PA and consists of a two-span continuous, Pratt through-truss, with counters. The bridge has an open deck with timber ties supported on a pair of longitudinal stringers. The overall length of the bridge is $222\pm$ feet. The bridge also has three prominent signal towers straddled across the top chords of both trusses. The Swing Bridge is currently inoperable and remains in the open position.

The center pier on which the bridge pivots is an octagon shaped, concrete-filled, granite faced pier supported on timber piling and constructed using the sunken caisson method around 1892. The height of the pier was raised 5.75' with an additional three courses of granite block in 1906. Rehabilitation was performed sometime after 1950 (based on the limited drawing information made available to HNTB) which consisted of installing steel plate around all eight sides of the pier extending down approximately 5' below MLW. The sheeting served as formwork for a reinforced concrete fill placed to form a protective jacket around the pier.

Similarly, the north and south rest piers are elongated hexagon shaped, concrete-filled piers constructed using the sunken caisson method presumably around 1892 as well. The caisson for the south rest pier is supported on timber piling whereas the north rest pier is founded on dense "hardpan". Both piers are skewed 11° to the centerline of track. Rehabilitation was performed at both piers sometime after 1912 which consisted of installing steel sheet piling around the perimeter of each pier and placing concrete into the annular space. The north rest pier measures 27.5'W x 54'L while the south rest pier is narrower and approximately 45' long.

- Inspection

Structural inspection of the bridge was performed in late October 2005 by HNTB personnel. The inspection involved gathering basic dimensional data, determining member sizes, identifying locations and extent of deterioration and visual observation of the trusses, floor beams, stringers and bracing components from above and below the track.

In general, the main truss components (i.e. diagonals, verticals, chords and end posts) exhibited light to moderate pitting and a uniformly oxidized surface. Built-up members consisting of angles/channels/plates, lacing bars, batten plates, gusset plates and rivet heads all exhibited full section thicknesses. There was little, if any, paint system remaining on any of the truss members however, although some paint residue was occasionally observed.

Similarly, the portal frames, knee-braces and diagonal bracing connecting the top chords of the trusses similarly exhibited light to moderate pitting and a uniformly oxidized surface with little, if any, section loss on these built-up members. Note, the signal towers were not inspected as part of this work.

There was an isolated section of the bottom chord on the east truss found to have significant deterioration for which a repair had been made. The top and bottom flanges of the channels that compose the member's cross section have from 50% to 100% loss. Previous repair of this member consisted of additional angles and/or side plates bolted to the side of the webs. The length of the repairs, however, were judged to be inadequate therefore, it is recommended that the entire continuous section of bottom chord between be replaced in-kind.

There is also exterior steel framing attached to the east truss that supports the operator's house. This framing, as well as the operator's house itself, is considered functionally obsolete and removal is recommended. New structural framing based on mechanical/electrical recommendations will be less expensive than salvaging existing.

The floor system consists of the stringers, floor beams, interior cross frames between stringers and diagonal bracing connecting the bottom chords. Typically, these components also exhibited light to moderate pitting and a uniformly oxidized surface with little section loss on these built-up members. The stringers on the southern half of the bridge are replacement stringers having the same dimensions as the original but bolted rather than riveted built-up members. These stringers are in good condition having little section loss. The remaining original stringers are also in good condition except for an eastern stringer. This stringer has 100% section loss along the bottom flange tips and along the web plate. In this same area, the floor beam has section losses similar to the supported stringer. Hence, it is recommended these two members be completely replaced. All other floor beams are in good condition.

Other areas where section loss was observed occurred at the lower clip angles of the stringer-to-floor beam connections. Here, holes through the web plate of the floor beam were observed at several locations. These holes were generally small, isolated and do not significantly affect the connection capacity. Therefore, it is recommended that these areas not be repaired.

The post 1950 rehabilitation of the center pier has severely deteriorated to the point where large voids in the reinforced concrete fill and steel plate have exposed the original granite blocks. Given this, it is recommended that the remains of the existing reinforced concrete fill and steel sheets be entirely removed and replaced. The replacement could consist of installing steel sheet piling extended well below the mud line and attaching it to an upper and lower steel ring frame which itself is attached to standoffs embedded into the original granite pier. The sheet piling would serve as formwork for a tremied concrete fill encapsulating the pier.

The north and south rest piers also require repairs. Inspection of the south rest pier showed large deteriorated areas of sheet piling and deep voids extending into the concrete fill. Inspection of the north rest pier showed sections of the sheet piling that has tilted and pulled away from the concrete fill. A timber whaler has been added at the southeast face in an attempt to halt the movement. Underwater inspection also revealed large deteriorated areas of sheet piling and deep voids extending into the concrete fill below the waterline similar to the south rest pier. Recommended repairs to the rest piers consists of replacing deteriorated sections of sheet piling and pressure grouting behind the piling to fill the voids. Additionally, at the south rest pier, the six steel H pilings exposed in front of the sheeting supporting the ends of

the embedded girders which apparently support the bridge bearings are severely deteriorated below the waterline. It is recommended that these H-piles also be replaced unless additional information reveals these embedded girders offer no support for the bridge bearings.

- Analysis

The bridge ratings given herein were based on the assumption that ordinary carbon steel manufactured in accordance with ASTM A7-09 "Standard Specifications for Structural Steel for Bridges" was used throughout the bridge. No mechanical or chemical testing was performed to verify this, however, the use of higher strength nickel and silicon steels was not typical practice for ordinary bridge construction, especially bridges of this span length.

A computer model was developed for the truss analyses based on actual member sizes measured in the field. Five separate load combinations were analyzed in accordance with AREMA Section 15-6.3.13 "Special Provisions for Swing Bridges" and Section 15-7.3 "Rating". The load combination producing the lowest results determines the rating. Both "Normal" and "Maximum" ratings were evaluated using a Cooper E series loading. Note, a minor live load impact reduction ($\approx 5\%$) was applied in accordance with AREMA Section 15-7.3.3.3 assuming a posted track speed of 30 MPH across the trestle.

Six diagonals require strengthening in order to achieve the desired Cooper E72 rating under the "Normal" condition defined as the load level which can be carried by the existing structure for its expected service life. However, no strengthening is required under the "Maximum" condition defined as the load level which the structure can support at infrequent intervals. Proposed costs for strengthening the bridge given below are based on the "Normal" condition.

The stringers and floor beams were also analyzed using hand computation. Both the stringers and floor beams require strengthening to achieve the desired Cooper E72 rating under the "Normal" condition, however, no strengthening is required under the "Maximum" condition.

Based on the results of these analyses, period of construction and previous bridge rating experience, the Back Cove Swing Bridge was likely originally designed to carry a Cooper E42 loading. This is based on the knowledge of allowable design stresses in common use at that time and the prevailing use of high-impact steam locomotives compared to more modern diesel and electric locomotives.

- Mechanical

The main components of the span drive, including racks, rack pinions, rack pinion shafts, and several pairs of open gearing are not salvageable

and require replacement. This is due to the heavy surface rust, exfoliation, section loss, and heavy wear observed in these components. The drive motors and brakes have been removed from the structure and require replacement. The bearings demonstrated evidence of excessive clearances due to the wear patterns in the open gearing. The balance wheel track, which is integral with the rack, demonstrated significant yielding, which further emphasizes the replacement of this component. The balance wheels were in poor condition demonstrating heavy surface rust and pitting and require replacement. Since replacement of these major components is required a complete replacement of the span drive is recommended.

It is recommended to jack the span off the center bearing (approximately 6") to remove and refurbish the center bearing assembly. It is anticipated, at a minimum, the bronze plate bushings within would need replacement.

The wedge drive machinery was generally in poor condition with worm gears and open gearing displaying varying degrees of surface rust and corrosion. These machinery components require replacement. The wedge drive motor and brake have been removed from the structure and require replacement. The longitudinal and lateral shafting displayed surface rust and pitting and should be replaced. Given these major components require replacement, new wedge drive machinery is recommended.

Several wedge assembly components are considered to be salvageable including the wedges, wedge supports, wedge seats, and cranks. These components will require removal from the structure for rehabilitation.

The center latch machinery requires rehabilitation including shaft and crank replacement. The rollers are not salvageable and also require replacement. The latch bar requires rehabilitation except for the roller wheels which should be replaced. The center latch seats can be re-used but require removal and rehabilitation.

The operating machinery for the rail joint system requires a full replacement.

- Electrical

Due to the lack of an existing electrical system it is recommended that a completely new power and control system be designed and constructed to place the bridge back into operation under current standards. The installation of a new electrical system may require both structural and mechanical modifications in order to meet current requirements of the National Electrical Code. A new control house will be required as the existing 10'x10' space may not be sufficient to house the necessary modern day equipment required.

The electrical estimate assumes that an operator will be on site to operate the bridge. If remote operation is desired, significant research into the

required data communications infrastructure will be required to generate an accurate estimate.

For the purposes of this study, it is assumed that this bridge will be rehabilitated and strengthened in order to meet an E72 loading requirement, The required action for this link includes full replacement of rail, open deck bridge timbers, walkway, railing, partial replacement of trestle structure on the existing alignment. The swing span will require structural rehabilitation, new electrical and partial replacement of the mechanical components. Signal improvements for the swing span and turnout from Link 1 are required.

DESCRIPTION	TOTAL
Trestle Repair Costs (Structural)	\$1,304,435.00
Swing Span Repair Costs (Structural)	\$997,060.00
Painting of Swing Span Costs	\$675,580.00
Swing Span Mechanical Costs	\$1,500,000.00
Swing Span Electrical Costs	\$825,000.00
Track Improvement Costs	\$1,296,378.00
Signal Improvement Costs	\$999,437.00
15% Contingency	\$1,284,043.41

TOTAL(ROUNDED) : \$8,880,000.00

Link 2 Assumptions

1. Unit prices gathered from latest DOT Bid Price Averages or from recent similar projects.
2. New interlocking consisting of a powered switch and bridge interface is required.
3. Operation of the swing span assumes a bridge operator.
4. Two osprey nests exist on Link 2; one on the swing span, other on utility pole. Nest mitigation costs not included in the estimate.
5. Maximum design speed of 30 mph anticipated on this link.

Link 3 – Portland Wye

This approximately 0.4 mile section of new track would be MaineDOT owned, connecting the Portland Transportation Center with the Proposed Union branch track.

The required action for this link includes new installation of rail, tie, ballast, and ditching on a new alignment. Improvements to several roadway and driveway crossings are required along this section. Modifications to the access and parking for the Cumberland County Jail might be necessary. Crossing of Congress Street and the Guilford Mainline double track would also be required.

The costs for Link 3 were provided by MaineDOT. See Appendix for detailed cost estimate.

DESCRIPTION	TOTAL
Track, Signal, & Highway Improvement Costs	\$3,950,000.00
15% Contingency	\$592,500.00

TOTAL(ROUNDED) : \$4,540,000.00

Link 3 Assumptions

1. Original cost estimate provided by DOT.
2. Unit prices adjusted for 3.5% annual inflation.

Link 4 – Proposed Union branch, South of Franklin Arterial

This partial replacement and partial new alignment track is owned by MaineDOT. The replacement section begins at the Guilford Mainline and extends over Park street, behind Hadlock Field and Deering Oaks Park, measuring approximately 0.6 miles in length. The required action for this section includes full replacement of rail, tie, and ballast on a similar alignment. Replacement of Park Street Bridge is included. A preliminary design report with recommended improvements was completed in 2003 for MaineDOT.

The new alignment section begins at Forest Ave and extends northerly within the I295 R/W across Preble Street and Franklin Arterial, measuring approximately 0.7 miles in length. The required action for this section includes new rail, tie, ballast, ditching and drainage on a new alignment. Signalization of three major roadway crossings is required along this section.

The costs for Link 4 are summarized below. See Appendix for detailed cost estimate.

DESCRIPTION	TOTAL
Track Improvement Costs	\$1,608,032.50
Signal Improvement Costs	\$828,565.00

Excavation, Drainage, Retaining Walls, Guardrail, Park St. Bridge Costs	\$1,891,837.50
10% Contingency	\$432,843.50

TOTAL(ROUNDED) : \$4,760,000.00

Link 4 Assumptions

1. Highway-rail grade crossings limited to track surface work on this Link. Estimates exclude highway improvements to Congress Street, Preble Street and Franklin Arterial.
2. Unit prices gathered from latest DOT Bid Price Averages or previous unit prices adjusted for 3.5% annual inflation.
3. MSE segmental retaining walls assumed in estimate
4. Maximum design speed of 30 mph anticipated on this link.
5. Maximum degree of curvature of 8 degrees
6. Turnout to Guilford Mainline not included in estimate
7. No freight traffic on this link.

Link 5 – Proposed Union branch, North of Franklin Arterial

This new alignment track will be owned by MaineDOT. This section begins at Franklin Arterial and extends northerly within the 1295 R/W under the Washington Ave Bridges to Back Cove, measuring approximately 0.6 miles in length. The required action for this section includes new rail, tie, ballast, ditching and drainage on a new alignment. Signalization of one bike path crossing is required along this section. Realignment of the Sewer Treatment Plant (STP) access road may be necessary as part of this work. A preliminary design report with recommended improvements was completed in 2003 for MaineDOT.

The costs for Link 5 are summarized below. See Appendix for detailed cost estimate.

DESCRIPTION	TOTAL
Track Improvement Costs	\$656,705.00
Signal Improvement Costs	\$143,654.00
Excavation, Drainage, Retaining Walls, GR, STP Road, Utilities, R/W Costs	\$1,161,312.50
10% Contingency	\$196,167.15

TOTAL(ROUNDED) : \$2,160,000.00

Link 5 Assumptions

1. Rail crossing estimates are for average road width of 30 feet and include pavement markings, additional crossing effort noted in Signal Pay Items
2. Unit prices gathered from latest DOT Bid Price Averages or previous unit prices adjusted for 3.5% annual inflation.
3. MSE segmental retaining walls assumed in estimate
4. Maximum design speed of 30 mph anticipated on this link.
5. Maximum degree of curvature of 8 degrees
6. Plate C Clearance under Washington Ave NB bridge.
7. No freight traffic on this link.
8. Design assumes no turnout at northern end (track will continue to Link 6 or Link 11, but not both).

Link 6 – Proposed Back Cove Bridge

This new bridge begins at the Portland Sewer Treatment Plant entrance and extends northerly across Back Cove between Tukey's Bridge and the existing Portland RR trestle and terminates at the north end of the existing RR trestle, measuring approximately 1,700 ft in length. This curved fixed structure includes maximum vertical grades of 3%. The final design of this ballasted deck bridge was completed in 2002 for MaineDOT.

The required action for this new bridge includes new substructure, superstructure, rail, tie, ballast, and approach work.

The costs for Link 6 are summarized below. See Appendix for detailed cost estimate.

DESCRIPTION	TOTAL
2005 Structure Costs	\$8,150,000.00
Track, Tie, Stone Costs	\$289,000.00
5% Contingency	\$421,950.00

TOTAL(ROUNDED) : \$8,860,000.00

Link 6 Assumptions

1. Original structure cost estimate excluded ballast, ties, and rail.
2. Structural concrete (pier and deck) and reinforcing steel unit costs adjusted individually.
3. All other structural costs adjusted at 3.5% annual inflation.

4. Assumes Link 11 will not be built with Link 6. Horizontal and vertical geometrics prohibit a turnout for Link 11.
5. Costs exclude hand-throw turnout required on Northern approach to allow SLR use of existing track for storage.

Link 7 – Portland RR Trestle to Proposed Yarmouth Station @ I295, Exit 15

This SLR owned section of track, measuring approximately 8.5 miles in length is currently active with freight operations. This section of track generally runs parallel to I295 from Portland to Yarmouth. A preliminary design report with recommended improvements was completed in 2003 for MaineDOT.

The required action for this link includes rehabilitation of track system, including ballast cleaning, partial ballast resurfacing, partial replacement of ties, and new 115 lb CWR. A proposed 3 mile siding is included in the costs. Improvements to numerous roadway crossings are required along this section. Rehabilitation of the 4-span Presumpscot River bridge is included in the costs.

The costs for Link 7 are summarized below. See Appendix for detailed cost estimate.

DESCRIPTION	TOTAL
Track Improvement Costs	\$7,005,040.40
3 Mi Siding Costs (Track, Signal, Earthwork)	\$5,749,450.00
Signal Improvement Costs	\$1,307,442.00
Roadway, Drainage, Presumpscot River Bridge Costs	\$1,924,500.00
10% Contingency	\$1,598,643.24

TOTAL(ROUNDED) : \$17,590,000.00

Link 7 Assumptions

1. Rail crossing estimates are for average road width of 30 feet and include pavement markings, additional crossing effort noted in Signal Pay Items
2. Unit prices gathered from latest DOT Bid Price Averages or previous unit prices adjusted for 3.5% annual inflation.
3. Proposed Yarmouth Station to be located north of the State Garage entrance at-grade crossing.
4. Removal of yard speed limits between MP 1.74 and MP 3.2 will be required to increase speeds.
5. Turnout reconfigurations in Deering Yard may be necessary. Cost not provided in estimate.

6. All hand throw switches on the main track to include electric locks.
7. Two new interlockings will be provided for the 3 miles siding with one powered turnout at each end.

Link 8 –Proposed Yarmouth Station @ I295, Exit 15 to Yarmouth Junction

This SLR owned section of track, measuring approximately 2.0 miles in length is currently active with freight operations. This section of track travels north parallel to I295 SB, continues through the Town of Yarmouth, over the Royal River and connects to the Guilford RR at Yarmouth Junction. A preliminary design report with recommended improvements was completed in 2003 for MaineDOT.

The required action for this link includes rehabilitation of track system, including ballast cleaning, partial ballast resurfacing, partial replacement of ties, and new 115 lb CWR. Improvements to numerous roadway crossings are required along this section. Rehabilitation of the Royal River bridge is included in the costs.

The costs for Link 8 are summarized below. See Appendix for detailed cost estimate.

DESCRIPTION	TOTAL
Track Improvement Costs	\$1,582,714.70
Signal Improvement Costs	\$902,704.00
Roadway, Drainage, Royal River Costs	\$1,488,750.00
10% Contingency	\$397,416.87

TOTAL(ROUNDED) : \$4,370,000.00

Link 8 Assumptions

1. Rail crossing estimates are for average road width of 30 feet and include pavement markings, additional crossing effort noted in Signal Pay Items
2. Unit prices gathered from latest DOT Bid Price Averages or previous unit prices adjusted for 3.5% annual inflation.
3. Proposed Yarmouth Station to be located north of the State Garage entrance at-grade crossing.
4. All hand throw switches on the main track to include electric locks.

Link 9 – Yarmouth Junction to Proposed Brunswick Station, Main Street

This mainly Guilford owned section of track (MaineDOT owns track section in Brunswick), measuring approximately 14.2 miles in length is currently active with freight operations. This section of track travels from Yarmouth, through downtown Freeport to Brunswick.

The required action for this link includes assumed rehabilitation of track system, including ballast cleaning, partial ballast resurfacing, partial replacement of ties, and new 115 lb CWR, similar to requirements proposed on the SLR, L7 & L8. Improvements to many roadway crossings are required along this section. Repair of small drainage structures is included in the costs.

Upgrade of the Yarmouth Junction to accommodate a connection with Link 8 is included in this cost.

The costs for Link 9 are summarized below. See Appendix for detailed cost estimate.

DESCRIPTION	TOTAL
Track Improvement Costs	\$11,213,820.84
Signal Improvement Costs	\$4,639,997.00
Roadway, Drainage, Small Bridge Costs	\$818,000.00
15% Contingency	\$2,500,772.68

TOTAL(ROUNDED) : \$19,170,000.00

Link 9 Assumptions

1. Rail crossing estimates are for average road width of 30 feet and include pavement markings, additional crossing effort noted in Signal Pay Items
2. Unit prices gathered from latest DOT Bid Price Averages or unit prices used on similar RR projects (SLR PDR) adjusted for 3.5% annual inflation.
3. Cost assumes existing 115 lb jointed rail, installed in the 1980's, is not reused on the project.
4. Replacement of plates on curves only.
5. Costs reflect proposed reconfiguration of proposed wye at Yarmouth Junction.
6. Ballasted deck assumed on all bridges.
7. Partial cost of new interlocking at Yarmouth Junction also included in Link 10. New interlocking to Brunswick will include two powered turnouts.
8. All hand throw switches on the main track to include electric locks.
9. 50% of the at-grade crossings require alignment modifications

Link 10 – Yarmouth Junction to Proposed Auburn Station, Intermodal Facility @ Airport

This SLR owned section of track, measuring approximately 18.2 miles in length is currently active with freight operations. This section of track travels from Yarmouth, through Pownal, New Gloucester to Auburn.

The required action for this link includes assumed rehabilitation of track system, including ballast cleaning, partial ballast resurfacing, partial replacement of ties, and new 115 lb CWR, similar to requirements proposed on the SLR, L7 & L8. Improvements to many roadway and stream crossings are required along this section, including six (6) Royal River crossings. Rehabilitation of eleven (11) structures is included in the costs.

The costs for Link 10 are summarized below. See Appendix for detailed cost estimate.

DESCRIPTION	TOTAL
Track Improvement Costs	\$14,334,637.90
Signal Improvement Costs	\$6,347,124.00
Structural Improvement Costs	\$5,947,390.00
Misc. Roadway & Drainage Costs	\$660,000.00
15% Contingency	\$4,093,372.79

TOTAL(ROUNDED) : \$31,380,000.00

Link 10 Assumptions

1. Rail crossing estimates are for average road width of 30 feet and include pavement markings, additional crossing effort noted in Signal Pay Items
2. Unit prices gathered from latest DOT Bid Price Averages or unit prices used on similar RR projects (SLR PDR) adjusted for 3.5% annual inflation.
3. Cost of new interlocking at Yarmouth Junction also included in Link 9.
4. Yard speed limits assumed to be removed to accommodate higher speeds at Danville Jct.
5. All hand throw switches on the main track to include electric locks.
6. 50% of the at-grade crossings require alignment modifications
7. New interlockings at Danville Junction (no powered turnouts) and new connection at Auburn airport (one powered turnout)

Link 11 – Proposed Union Branch connection to Portland Waterfront RR

This new alignment section of track, measuring approximately 2,000 ft. in length, begins near the Portland Sewer Treatment Plant entrance and extends easterly around the treatment plant along the existing shoreline, connecting with the existing Portland waterfront RR corridor.

The required action for this section includes new rail, tie, ballast, ditching and drainage on a new alignment. Relocation of the existing bike path is required at two locations. Several retaining walls are required as part of this work.

The costs for Link 11 are summarized below. See Appendix for detailed cost estimate.

DESCRIPTION	TOTAL
Track Costs	\$495,500.00
Structural Retaining Wall Costs	\$769,500.00
Excavation, Bike Path, Drainage, Riprap, R/W Costs	\$553,625.00
15% Contingency	\$272,793.75

TOTAL(ROUNDED) : \$2,090,000.00

Link 11 Assumptions

1. Unit prices gathered from latest DOT Bid Price Averages or unit prices used on similar RR projects (UB PDR) adjusted for 3.5% annual inflation.
2. MSE segmental retaining walls assumed in estimate
3. Cost for mitigation of coastal wetlands not included. It is assumed that impacts of coastal wetlands can be permitted.
4. Maximum design speed of 30 mph anticipated on this link.
5. R/W costs assumed, not based on any research.
6. Estimate excludes potential displacement or protection of existing utilities associated with the Sewer Treatment Plant.
7. Design assumes no turnout to Link 6.

4. RAIL CORRIDOR COSTS

Below is a summary of possible commuter rail corridors and their associated infrastructure costs, based on the developed construction costs estimates. The costs noted in this section do not include layover facilities, train stations, additional sidings, engineering, inspection, or land acquisition.

Portland Transportation Center to Brunswick

This is the original alignment proposed as part of Portland North Passenger Rail Service Extension Project, as part of the extension of Amtrak service north of Portland. This option would travel along Marginal Way in Portland, across Back Cove, north to Yarmouth, then through Freeport to Brunswick. This corridor would not utilize the existing Portland RR trestle, instead using the proposed Back Cove Bridge.

LINK	DESCRIPTION	TOTAL
L3	Portland Wye Junction	\$4,540,000.00
L4	Proposed Union Branch, South of Franklin Arterial	\$4,760,000.00
L5	Proposed Union Branch, North of Franklin Arterial	\$2,160,000.00
L6	Proposed Back Cove Bridge	\$8,860,000.00
L7	SLR, Portland Trestle to Proposed Yarmouth Station @ I295, Exit 15	\$17,590,000.00
L8	SLR, Proposed Yarmouth Station @ I295, Exit 15 to Yarmouth Junction	\$4,370,000.00
L9	Guilford, Yarmouth Junction to Proposed Brunswick Station, Main Street	\$19,170,000.00

TOTAL: \$61,450,000.00

Portland Transportation Center to Auburn

This option would travel along Marginal Way in Portland, across Back Cove, north to Yarmouth, then north to the Pineland Center and terminating at the Auburn Intermodal Facility. This corridor would not utilize the existing Portland RR trestle, instead using the proposed Back Cove Bridge.

LINK	DESCRIPTION	TOTAL
L3	Portland Wye Junction	\$4,540,000.00
L4	Proposed Union Branch, South of Franklin Arterial	\$4,760,000.00
L5	Proposed Union Branch, North of Franklin Arterial	\$2,160,000.00
L6	Proposed Back Cove Bridge	\$8,860,000.00
L7	SLR, Portland Trestle to Proposed Yarmouth Station @ I295, Exit 15	\$17,590,000.00

L8	SLR, Proposed Yarmouth Station @ I295, Exit 15 to Yarmouth Junction	\$4,370,000.00
L10	SLR, Yarmouth Junction to Auburn Intermodal Facility	\$31,380,000.00

TOTAL: \$73,660,000.00

Portland Gateway to Brunswick

This option would begin at the Portland Ocean Gateway, travel along the Narrow Gauge alignment, across the existing Portland RR Trestle north to Yarmouth Junction, then through Freeport to Brunswick.

LINK	DESCRIPTION	TOTAL
L1	Portland Waterfront to Portland Trestle South	\$4,890,000.00
L2	Portland Trestle	\$8,880,000.00
L7	SLR, Portland Trestle to Proposed Yarmouth Station @ I295, Exit 15	\$17,590,000.00
L8	SLR, Proposed Yarmouth Station @ I295, Exit 15 to Yarmouth Junction	\$4,370,000.00
L9	Guilford, Yarmouth Junction to Proposed Brunswick Station, Main Street	\$19,170,000.00

TOTAL: \$54,900,000.00

Portland Gateway to Auburn

This option would begin at the Portland Ocean Gateway, travel along the Narrow Gauge alignment, across the existing Portland RR Trestle north to Yarmouth Junction, then north to the Pineland Center and terminating at the Auburn Intermodal Facility.

LINK	DESCRIPTION	TOTAL
L1	Portland Waterfront to Portland Trestle South	\$4,890,000.00
L2	Portland Trestle	\$8,880,000.00
L7	SLR, Portland Trestle to Proposed Yarmouth Station @ I295, Exit 15	\$17,590,000.00
L8	SLR, Proposed Yarmouth Station @ I295, Exit 15 to Yarmouth Junction	\$4,370,000.00
L10	SLR, Yarmouth Junction to Auburn Intermodal Facility	\$31,380,000.00

TOTAL: \$67,110,000.00

Portland Transportation Center to Portland Ocean Gateway

This option could be combined with the previous two options that connect Portland Ocean Gateway to either Brunswick or Auburn. This link would provide connectivity between the Amtrak "Downeaster" service and commuter service North of

Portland. The option would travel along Marginal Way in Portland, around the Eastern Promenade on a new alignment just north of the existing Portland Sewer Treatment Plant, and connect with the Narrow Gauge alignment.

LINK	DESCRIPTION	TOTAL
L3	Portland Wye Junction	\$4,540,000.00
L4	Proposed Union Branch, South of Franklin Arterial	\$4,760,000.00
L5	Proposed Union Branch, North of Franklin Arterial	\$2,160,000.00
L11	Proposed Union Branch Extension to Portland Waterfront RR	\$2,090,000.00

TOTAL: \$13,550,000.00

5. STATION PLATFORM COSTS & ADDITIONAL SIDINGS

The Portland North Alternatives Review Report being completed by KKO and Associates for commuter rail service North of Portland has identified numerous station platforms and passing sidings.

Station Platforms

The following nine (9) locations have been identified as future train station (platform) sites:

LOCATION (NODE)	DESCRIPTION
Ocean Gateway (N1)	Portland Waterfront Station - Proposed Hancock Street Extension
Bayside (N6)	Bayside Station, Marginal Way & Franklin Arterial
East Deering	East Deering Station - Presumpscot Street
Falmouth	Falmouth Station - I-295 Exit 10
Yarmouth (N8)	Yarmouth Station - I-295 Exit 15
Freeport	Freeport Station - Park Street
Brunswick (N10)	Brunswick Station - Maine Street
Pineland	Pineland Station - Route 231
Auburn (N11)	Auburn Station, Auburn Intermodal Facility & Airport

Conceptual cost estimates have been developed for each of the platform sites. In some cases, numerous cost estimates are provided for each site, depending on the requirements established by KKO and Associates. The following cost estimates include track, signal, structural (platforms), and site costs. Site costs include parking, access, lighting, and drainage.

Assumptions made during this assignment are documented at the end of this section.

Ocean Gateway Station (0.2 mi double track)

Per KKO and Associates recommendation, this station will include a double track (0.2 mi) with a center platform, 200-ft in length. No plans for proposed parking at this location.

DESCRIPTION	TOTAL
Track Siding Costs	\$265,000.00
Signal Costs	\$771,825.00
Platform Costs	\$130,000.00
Site & Parking Costs	\$0.00
Lighting Costs	\$25,000.00
15% Contingency	\$178,700.00

TOTAL(ROUNDED) : \$1,370,500.00

Ocean Gateway Station (0.4 mi double track)

Per KKO and Associates recommendation, this station will include a double track (0.4 mi) with a center platform, 200-ft in length. No plans for proposed parking at this location.

DESCRIPTION	TOTAL
Track Siding Costs	\$444,000.00
Signal Costs	\$771,825.00
Platform Costs	\$130,000.00
Site & Parking Costs	\$0.00
Lighting Costs	\$25,000.00
15% Contingency	\$205,600.00

TOTAL(ROUNDED) : \$1,576,500.00

Bayside Station (0.2 mi double track)

Per KKO and Associates recommendation, this station will include a double track (0.2 mi) with a center platform, 200-ft in length. Existing parking is available at this site.

DESCRIPTION	TOTAL
Track Siding Costs	\$265,000.00
Signal Costs	\$771,825.00
Platform Costs	\$130,000.00
Site & Parking Costs	\$0.00
Lighting Costs	\$25,000.00
15% Contingency	\$178,700.00

TOTAL(ROUNDED) : \$1,370,500.00

Bayside Station (0.4 mi double track)

Per KKO and Associates recommendation, this station will include a double track (0.4 mi) with a center platform, 200-ft in length. Existing parking is available at this site.

DESCRIPTION	TOTAL
Track Siding Costs	\$444,000.00
Signal Costs	\$771,825.00
Platform Costs	\$130,000.00
Site & Parking Costs	\$0.00
Lighting Costs	\$25,000.00
15% Contingency	\$205,600.00

TOTAL(ROUNDED) : \$1,576,500.00

East Deering Station (single track)

Per KKO and Associates recommendation, this station will include a single track with a side platform, 200-ft in length. Existing parking is available at this site.

DESCRIPTION	TOTAL
Track Siding Costs	\$0.00
Signal Costs	\$0.00
Platform Costs	\$65,000.00
Site & Parking Costs	\$0.00
Lighting Costs	\$25,000.00
15% Contingency	\$13,500.00

TOTAL(ROUNDED) : \$103,500.00

East Deering Station (0.4 mi double track)

Per KKO and Associates recommendation, this station will include a double track (0.4 mi) with a center platform, 200-ft in length. Existing parking is available at this site.

DESCRIPTION	TOTAL
Track Siding Costs	\$444,000.00
Signal Costs	\$771,825.00
Platform Costs	\$130,000.00
Site & Parking Costs	\$0.00
Lighting Costs	\$25,000.00
15% Contingency	\$205,600.00

TOTAL(ROUNDED) : \$1,576,500.00

Falmouth Station (single track)

Per KKO and Associates recommendation, this station will include a single track with a side platform, 200-ft in length. Proposed parking for 100 vehicles is assumed at this site.

DESCRIPTION	TOTAL
Track Siding Costs	\$0.00
Signal Costs	\$0.00
Platform Costs	\$65,000.00
Site & Parking Costs	\$125,000.00
Lighting Costs	\$25,000.00
15% Contingency	\$32,250.00

TOTAL(ROUNDED) : \$247,250.00

Falmouth Station (0.2 mi double track)

Per KKO and Associates recommendation, this station will include a double track (0.2 mi) with staggered side platforms, 200-ft in length each. Two turnouts are assumed. Proposed parking for 100 vehicles is assumed at this site.

DESCRIPTION	TOTAL
Track Siding Costs	\$440,000.00
Signal Costs	\$1,543,650.00
Platform Costs	\$130,000.00
Site & Parking Costs	\$125,000.00
Lighting Costs	\$25,000.00
15% Contingency	\$339,500.00

TOTAL(ROUNDED) : \$2,603,000.00

Falmouth Station (0.4 mi double track)

Per KKO and Associates recommendation, this station will include a double track (0.4 mi) with staggered side platforms, 200-ft in length each. Two turnouts are assumed. Proposed parking for 100 vehicles is assumed at this site.

DESCRIPTION	TOTAL
Track Siding Costs	\$619,000.00
Signal Costs	\$1,543,650.00
Platform Costs	\$130,000.00
Site & Parking Costs	\$125,000.00
Lighting Costs	\$25,000.00
15% Contingency	\$366,400.00

TOTAL(ROUNDED) : \$2,809,000.00

Yarmouth Station, Exit 15 (single track)

Per KKO and Associates recommendation, this station will include a single track with a side platform, 200-ft in length. Proposed parking for 500 vehicles at this site.

DESCRIPTION	TOTAL
Track Siding Costs	\$0.00
Signal Costs	\$0.00
Platform Costs	\$65,000.00
Site & Parking Costs	\$625,000.00
Lighting Costs	\$125,000.00
15% Contingency	\$122,250.00

TOTAL(ROUNDED) : \$937,250.00

Yarmouth Station, Exit 15 (0.2 mi double track)

Per KKO and Associates recommendation, this station will include a double track (0.2 mi) with a center platform, 200-ft in length each. Proposed parking for 500 vehicles at this site.

DESCRIPTION	TOTAL
Track Siding Costs	\$265,000.00
Signal Costs	\$771,825.00
Platform Costs	\$130,000.00
Site & Parking Costs	\$625,000.00
Lighting Costs	\$125,000.00
15% Contingency	\$287,500.00

TOTAL(ROUNDED) : \$2,204,300.00

Freeport Station, (single track)

Per KKO and Associates recommendation, this station will include a single track with a side platform, 200-ft in length. Proposed parking for 100 vehicles is assumed at this site.

DESCRIPTION	TOTAL
Track Siding Costs	\$0.00
Signal Costs	\$0.00
Platform Costs	\$65,000.00
Site & Parking Costs	\$125,000.00
Lighting Costs	\$25,000.00
15% Contingency	\$32,250.00

TOTAL(ROUNDED) : \$247,250.00

Brunswick Station (0.4 mi double track)

Per KKO and Associates recommendation, this station will include a double track (0.4 mi) with center platform, 200-ft in length. Proposed parking for 100 vehicles is assumed at this site.

DESCRIPTION	TOTAL
Track Siding Costs	\$444,000.00
Signal Costs	\$771,825.00
Platform Costs	\$130,000.00
Site & Parking Costs	\$125,000.00
Lighting Costs	\$25,000.00
15% Contingency	\$224,400.00

TOTAL(ROUNDED) : \$1,720,250.00

Pineland Station, (single track)

Per KKO and Associates recommendation, this station will include a single track with a side platform, 200-ft in length. Proposed parking for 100 vehicles is assumed at this site.

DESCRIPTION	TOTAL
Track Siding Costs	\$0.00
Signal Costs	\$0.00
Platform Costs	\$65,000.00
Site & Parking Costs	\$125,000.00
Lighting Costs	\$25,000.00
15% Contingency	\$32,250.00

TOTAL(ROUNDED) : \$247,250.00

Auburn Station (0.4 mi double track)

Per KKO and Associates recommendation, this station will include a double track (0.4 mi) with center platform, 200-ft in length. Proposed parking for 100 vehicles is assumed at this site.

DESCRIPTION	TOTAL
Track Siding Costs	\$444,000.00
Signal Costs	\$771,825.00
Platform Costs	\$130,000.00
Site & Parking Costs	\$125,000.00
Lighting Costs	\$25,000.00
15% Contingency	\$224,400.00

TOTAL(ROUNDED) : \$1,720,250.00

Station Platform Assumptions

1. Platform locations and track requirements per KKO and Associates recommendations.
2. Wayside signal system assumed.
3. Estimates developed without site visits. Sites assumed to be level with no major earthwork.
4. Platform height to be high-level only. Platform length to be 200-ft. Platform width to be 10-ft for side or staggered platforms and 20-ft for center platforms.
5. Platforms assumed to be constructed from 10' wide Pre-cast double-tee concrete girders, set on cast-in-place concrete piers placed 20-ft. on center.
6. Platform costs include railing, ADA access, steps, and signage.
7. High level platforms may conflict with freight rail service. Estimates do not account for specialty equipment necessary to allow for freight and commuter rail traffic.
8. Estimates assume no buildings, public facilities, or canopy at train stations.
9. Fare collection has not been considered in this analysis.
10. Layover facilities excluded from estimates.
11. Track, site, and signal improvements necessary for pedestrian RR crossings not included in the estimates.
12. Estimates assume no fencing is required.
13. Track and signal costs based on unit cost information developed for links. Costs assume no track subgrade work. No road at-grade crossings or structures are assumed in areas of double track.
14. Ballasted track assumed at stations. Direct fixation of track to platform not considered in the costs.
15. Parking areas to be built with 3" pavement on 15" gravel base. Parking stalls to be 9' by 18' with 24' wide aisles. Limited drainage costs included in the estimates.

Additional Sidings

Numerous additional sidings are recommended along the study links, per KKO and Associates recommendations. The following two sidings lengths have been identified; 0.2 mile and 0.4 mile.

Siding (0.2 mi)

DESCRIPTION	TOTAL
Track Costs	\$440,000.00
Signal Costs	\$1,543,650.00

TOTAL(ROUNDED) : \$1,984,000.00

Siding (0.4 mi)

DESCRIPTION	TOTAL
Track Costs	\$619,000.00
Signal Costs	\$1,543,650.00

TOTAL(ROUNDED) : \$2,163,000.00

Additional Siding Assumptions

1. Wayside signal system assumed.
2. Estimates developed without site visits. Sites assumed to be level with no major earthwork.
3. Track and signal costs based on unit cost information developed for links. Costs assume no track subgrade work. No road at-grade crossings or structures are assumed in areas of double track.

APPENDIX

- Breakdown of Preliminary Construction Costs for each Link
- Portland RR Trestle Underwater Inspection Report

LINK 1

Portland Waterfront to Portland Trestle South

Portland Commuter Rail Study
PIN 9503.20



PRELIMINARY ENGINEER'S ESTIMATE

November 14, 2005

TRACK PAY ITEMS

ITEM NO.	DESCRIPTION	UNIT	QUANTITY	UNIT PRICE	TOTAL
	INSTALL 115# CWR (Rail) 3rd rail NGRR	TK MI	0.71	\$475,085.00	\$337,310.35
	INSTALL #10 TURNOUT NGRR	EA	6	\$85,000.00	\$510,000.00
	RELOCATE NGRR TURNOUT	EA	1	\$25,000.00	\$25,000.00
	RELOCATE NGRR TRACK	TK FT	1200	\$20.00	\$24,000.00
	INSTALL 115# CWR TRACK, TIES, STONE, ETC	TK FT	6700	\$170.00	\$1,139,000.00
	DITCH TRACK	TK MI	1.42	\$29,520.00	\$41,918.40
	BRUSH CUT	TK MI	0.2	\$7,825.00	\$1,565.00
	REPLACE GRADE CROSSING	EA	7	\$43,714.00	\$305,998.00
	REMOVE TRACK	LF	9500	\$6.15	\$58,425.00
	NEW STATION PLATFORM NGRR	LS	1	\$10,000.00	\$10,000.00
	NGRR YARD UPGRADES	LS	1	\$60,000.00	\$60,000.00
	CHAIN LINK FENCE	LF	7000	\$15.00	\$105,000.00

TRACK TOTAL: \$2,618,216.75

SIGNAL PAY ITEMS

ITEM NO.	DESCRIPTION	MATERIAL	LABOR	EQUIPMENT	TOTAL
	ROAD CROSSING 1 & 2 AND STATION SIGNAL	\$258,687	\$56,942	\$14,025	\$329,654
	BIKE PATH CROSSING 1	\$125,822	\$41,225	\$11,725	\$178,772
	PRIVATE CROSSING 1	\$125,822	\$41,225	\$11,725	\$178,772
	PRIVATE CROSSING 2	\$125,822	\$41,225	\$11,725	\$178,772
	CUTTER ST	\$125,822	\$41,225	\$11,725	\$178,772
	BIKE PATH CROSSING 2 (STANDARD GAUGE)	\$104,267	\$30,192	\$9,195	\$143,654
	EXPRESS CABLE AND MNGRR SWITCH PROTECT.	\$60,700	\$25,510	\$4,700	\$90,910

SIGNAL TOTAL: \$1,279,306.00

MISC. PAY ITEMS

ITEM NO.	DESCRIPTION	UNIT	QUANTITY	UNIT PRICE	TOTAL
	ROADWAY APPROACH GRADE IMPROVEMENTS	LS	5	\$56,000.00	\$280,000.00
	DRAINAGE - PIPES/UNDERDRAIN	LF	400	\$55.00	\$22,000.00
	WALL REPAIR - EROSION CONTROL FABRIC	SY	1,700	\$5.00	\$8,500.00
	WALL REPAIR - GRAVEL	CY	2,000	\$20.00	\$40,000.00
	SEWAGE PLANT ROAD & BIKE PATH	SF	0	\$11.00	\$0.00

MISC. TOTAL: \$350,500.00

NOTES:

1. See Feasibility Report for Cost Assumptions

SUBTOTAL: \$4,248,022.75
15% Contingency: \$637,203.41
TOTAL: \$4,885,226.16

SAY: \$4,890,000

LINK 2

Portland Trestle

Portland Commuter Rail Study PIN 9503.20



PRELIMINARY ENGINEER'S ESTIMATE
November 14, 2005

STRUCTURAL PAY ITEMS (TRESTLE)

ITEM NO.	DESCRIPTION	UNIT	QUANTITY	UNIT PRICE	TOTAL
N. ABUT SOUTH 600'	SELECT PILE, BENT CAP, BRACING REPLACEMENT	LF	600	\$398.00	\$238,800.00
	REMOVE, RESET, STRENGTHEN STRINGERS	LF	600	\$262.00	\$157,200.00
SOUTH TO SWING SPAN 150'	SELECT PILE REPLACEMENT, BENT STRENGTHING	LF	150	\$713.00	\$106,950.00
	SELECT BENT CAP, BRACING REPLACEMENT	LF	150	\$128.00	\$19,200.00
	REMOVE, RESET, STRENGTHEN STRINGERS	LF	150	\$262.00	\$39,300.00
MAJOR BURN SECTION	NEW PILES, BENT CAP, BRACING, STRINGERS	LF	150	\$1,519.00	\$227,850.00
MINOR BURN SECTION	NEW PILES, BENT CAP, BRACING, STRINGERS	LF	250	\$1,111.00	\$277,750.00
S. ABUT NORTH 180'	SELECT PILE, BENT CAP, BRACING REPLACEMENT	LF	180	\$398.00	\$71,640.00
	REMOVE, RESET, STRENGTHEN STRINGERS	LF	180	\$262.00	\$47,160.00
	MOBILIZATION	LS	1	\$118,585.00	\$118,585.00
STRUCT. TOTAL:					\$1,304,435.00

STRUCTURAL PAY ITEMS (SWING SPAN)

ITEM NO.	DESCRIPTION	UNIT	QUANTITY	UNIT PRICE	TOTAL
	SUPERSTRUCTURE REHABILITATION	LS	1	\$503,560.00	\$503,560.00
	STRUCTURE PAINTING, CONTAINMENT, DISPOSAL	LS	1	\$675,580.00	\$675,580.00
	SUBSTRUCTURE REPAIR	LS	1	\$493,500.00	\$493,500.00
STRUCT. TOTAL:					\$1,672,640.00

TRACK PAY ITEMS

ITEM NO.	DESCRIPTION	UNIT	QUANTITY	UNIT PRICE	TOTAL
	INSTALL 115# CWR (Rail)	LF	3108	\$72.00	\$223,776.00
	INSTALL MITER RAILS	EA	4	\$30,000.00	\$120,000.00
	INSTALL WALKWAY	LF	1554	\$38.00	\$59,052.00
	INSTALL RAILING	LF	1554	\$125.00	\$194,250.00
	OPEN DECK BRIDGE TIMBER	EA	1332	\$525.00	\$699,300.00
TRACK TOTAL:					\$1,296,378.00

SIGNAL PAY ITEMS

ITEM NO.	DESCRIPTION	MATERIAL	LABOR	EQUIPMENT	TOTAL
	MOVEABLE BRIDGE INTERLOCKING	\$374,781	\$570,668	\$53,988	\$999,437
SIGNAL TOTAL:					\$999,437.00

ELECTRICAL PAY ITEMS

ITEM NO.	DESCRIPTION	UNIT	QUANTITY	UNIT PRICE	TOTAL
	Intercom System	LS	1	\$20,000.00	\$20,000.00
	Lighting (Control House and Navigation)	LS	1	\$20,000.00	\$20,000.00
	Bridge Electrical Service	LS	1	\$75,000.00	\$75,000.00
	Emergency Generator	LS	1	\$60,000.00	\$60,000.00
	Submarine Cables	LS	1	\$150,000.00	\$150,000.00
	Control Console/PLC Cabinets	LS	1	\$100,000.00	\$100,000.00
	Motor Control Centers	LS	1	\$75,000.00	\$75,000.00

Portland Trestle

Portland Commuter Rail Study
PIN 9503.20



PRELIMINARY ENGINEER'S ESTIMATE
November 14, 2005

Span Drive Systems (Main/Aux)	LS	1	\$100,000.00	\$100,000.00
Lightning Protection System	LS	1	\$25,000.00	\$25,000.00
Conduit and Wiring	LS	1	\$150,000.00	\$150,000.00
Miscellaneous	LS	1	\$25,000.00	\$25,000.00
Startup Services	LS	1	\$15,000.00	\$15,000.00
Training and Documentation	LS	1	\$10,000.00	\$10,000.00
			MISC. TOTAL:	\$825,000.00

MECHANICAL PAY ITEMS

ITEM NO.	DESCRIPTION	UNIT	QUANTITY	UNIT PRICE	TOTAL
	Span Drive Machinery	LS	1	\$900,000.00	\$900,000.00
	Wedge Drive Machinery	LS	1	\$300,000.00	\$300,000.00
	Wedge Assembly Rehabilitation	LS	1	\$100,000.00	\$100,000.00
	Rail Lift Machinery	LS	1	\$100,000.00	\$100,000.00
	Center Latch Machinery	LS	1	\$50,000.00	\$50,000.00
	Center Bearing Rehabilitation	LS	1	\$50,000.00	\$50,000.00
			MISC. TOTAL:	\$1,500,000.00	

NOTES:

1. See Feasibility Report for Cost Assumptions

SUBTOTAL: \$7,597,890.00
15% Contingency: \$1,284,043.41
TOTAL: \$8,881,933.41

SAY: \$8,880,000

LINK 3

Portland Wye

Portland Commuter Rail Study PIN 9503.20



PRELIMINARY ENGINEER'S ESTIMATE November 14, 2005

MAY, 2004

ITEM NO.	DESCRIPTION	UNIT	QUANTITY	UNIT PRICE	TOTAL
	DOT COST ESTIMATE	LS	1	\$3,750,000.00	\$3,750,000.00
2004 TOTAL:					\$3,750,000.00

NOV, 2005

ITEM NO.	CROSSING DESCRIPTION	UNIT	QUANTITY	UNIT PRICE	TOTAL
	REVISED COST ESTIMATE	LS	1	\$3,950,000.00	\$3,950,000.00
2005 TOTAL:					\$3,950,000.00

NOTES:

1. See Feasibility Report for Cost Assumptions

SUBTOTAL: \$3,950,000.00
15% Contingency: \$592,500.00
TOTAL: \$4,542,500.00

SAY: \$4,540,000

LINK 4

Proposed Union Branch, South of Franklin Art.

Portland Commuter Rail Study
PIN 9503.20



PRELIMINARY ENGINEER'S ESTIMATE
November 14, 2005

TRACK PAY ITEMS

ITEM NO.	DESCRIPTION	UNIT	QUANTITY	UNIT PRICE	TOTAL
	INSTALL 115# CWR TRACK, TIES, STONE, ETC	TK FT	6100	\$170.00	\$1,037,000.00
	DITCH TRACK (EXISTING ALGN)	TK MI	0.75	\$29,520.00	\$22,140.00
	BRUSH CUT (EXISTING ALGN)	TK MI	0.5	\$7,825.00	\$3,912.50
	REPLACE GRADE CROSSING	EA	3	\$120,000.00	\$360,000.00
	REMOVE TRACK	LF	5800	\$6.15	\$35,670.00
	FENCING	LF	3500	\$15.00	\$52,500.00
	IMPROVEMENTS BR. (PARK ST)	LS	1	\$71,400.00	\$71,400.00
	INSTALL CRASH WALLS	EA	2	\$12,705.00	\$25,410.00

TRACK TOTAL: \$1,608,032.50

SIGNAL PAY ITEMS

ITEM NO.	DESCRIPTION	MATERIAL	LABOR	EQUIPMENT	TOTAL
	FOREST AVE	\$255,510	\$64,870	\$14,025	\$334,405
	PREBLE STREET	\$177,714	\$51,067	\$11,725	\$240,506
	FRANKLIN STREET EXTENSION	\$183,343	\$56,976	\$13,335	\$253,654

SIGNAL TOTAL: \$828,565.00

MISC. PAY ITEMS

ITEM NO.	DESCRIPTION	UNIT	QUANTITY	UNIT PRICE	TOTAL
	COMMON EXCAVATION	CY	21,250	\$12.75	\$270,937.50
	DRAINAGE - CATCH BASINS	EA	11	\$2,400.00	\$26,400.00
	DRAINAGE - PIPES/UNDERDRAIN	LF	2,400	\$55.00	\$132,000.00
	RETAINING WALLS	SF	8,500	\$28.50	\$242,250.00
	GUARDRAIL	LF	1,500	\$13.50	\$20,250.00
	BRIDGE REPLACEMENT - PARK STREET	LS	1	\$1,200,000.00	\$1,200,000.00

MISC. TOTAL: \$1,891,837.50

NOTES:

1. See Feasibility Report for Cost Assumptions

SUBTOTAL: \$4,328,435.00
10% Contingency: \$432,843.50
TOTAL: \$4,761,278.50

SAY: \$4,760,000

LINK 5

Proposed Union Branch, North of Franklin Art.

Portland Commuter Rail Study PIN 9503.20



PRELIMINARY ENGINEER'S ESTIMATE

November 14, 2005

TRACK PAY ITEMS

ITEM NO.	DESCRIPTION	UNIT	QUANTITY	UNIT PRICE	TOTAL
	INSTALL 115# CWR TRACK, TIES, STONE, ETC	TK FT	3300	\$170.00	\$561,000.00
	REPLACE GRADE CROSSING	EA	1	\$38,000.00	\$38,000.00
	FENCING	LF	3000	\$15.00	\$45,000.00
	INSTALL CRASH WALLS	EA	1	\$12,705.00	\$12,705.00
TRACK TOTAL:					\$656,705.00

SIGNAL PAY ITEMS

ITEM NO.	DESCRIPTION	MATERIAL	LABOR	EQUIPMENT	TOTAL
	BIKE PATH CROSSING	\$104,267	\$30,192	\$9,195	\$143,654
SIGNAL TOTAL:					\$143,654.00

MISC. PAY ITEMS

ITEM NO.	DESCRIPTION	UNIT	QUANTITY	UNIT PRICE	TOTAL
	COMMON EXCAVATION	CY	5,750	\$12.75	\$73,312.50
	DRAINAGE - CATCH BASINS	EA	13	\$2,400.00	\$31,200.00
	DRAINAGE - PIPES/UNDERDRAIN	LF	2,400	\$55.00	\$132,000.00
	RETAINING WALLS	SF	3,900	\$28.50	\$111,150.00
	GUARDRAIL	LF	2,500	\$13.50	\$33,750.00
	CONCRETE BARRIER	LF	600	\$125.00	\$75,000.00
	SEWAGE PLANT ROAD & BIKE PATH	SF	40,000	\$11.00	\$440,000.00
	UTILITY - HIGH TOWER LIGHTING	EA	1	\$45,000.00	\$45,000.00
	UTILITY - STD LIGHTING	EA	12	\$2,700.00	\$32,400.00
	UTILITY - 60"RCP	LF	500	\$350.00	\$175,000.00
	RIGHT-OF-WAY - PROPERTY ACQUISITION	LS	1	\$12,500.00	\$12,500.00
MISC. TOTAL:					\$1,161,312.50

NOTES:

1. See Feasibility Report for Cost Assumptions

SUBTOTAL: \$1,961,671.50
10% Contingency: \$196,167.15
TOTAL: \$2,157,838.65

SAY: \$2,160,000

LINK 6

Proposed Back Cove Bridge

Portland Commuter Rail Study
PIN 9503.20



PRELIMINARY ENGINEER'S ESTIMATE
November 15, 2005

SEPT, 2002

ITEM NO.	DESCRIPTION	UNIT	QUANTITY	UNIT PRICE	TOTAL
	HNTB COST ESTIMATE- STRUCTURE ONLY	LS	1	\$6,500,000.00	\$6,500,000.00
2002 TOTAL:					\$6,500,000.00

NOV, 2005

ITEM NO.	DESCRIPTION	UNIT	QUANTITY	UNIT PRICE	TOTAL
	REVISED COST ESTIMATE - STRUCTURE ONLY	LS	1	\$8,150,000.00	\$8,150,000.00
	INSTALL 115# CWR TRACK, TIES, STONE, ETC	TK FT	1700	\$170.00	\$289,000.00
2005 TOTAL:					\$8,439,000.00

NOTES:

1. See Feasibility Report for Cost Assumptions

SUBTOTAL: \$8,439,000.00
5% Contingency: \$421,950.00
TOTAL: \$8,860,950.00

SAY: \$8,860,000

LINK 7

SLR, Portland Trestle to Proposed Yarmouth Station @ I295, Exit 15

Portland Commuter Rail Study PIN 9503.20



PRELIMINARY ENGINEER'S ESTIMATE
November 14, 2005

TRACK PAY ITEMS

ITEM NO.	DESCRIPTION	UNIT	QUANTITY	UNIT PRICE	TOTAL
	INSTALL TIES	EA	6778	\$90.00	\$610,020.00
	INSTALL 115# CWR (Rail)	TK MI	8.88	\$475,085.00	\$4,218,754.80
	SURFACE TRACK 2 PASS 4" LIFT	MI	8.88	\$39,266.00	\$348,682.08
	INSTALL 3 MILE PASSING SIDING	LS	1	\$2,965,800.00	\$2,965,800.00
	INSTALL #10 TURNOUT	EA	6	\$85,000.00	\$510,000.00
	INSTALL #8 TURNOUT	EA	1	\$109,733.00	\$109,733.00
	DITCH TRACK	TK MI	3.55	\$29,520.00	\$104,796.00
	BRUSH CUT	TK MI	8.88	\$7,825.00	\$69,486.00
	CLEAN SHOULDER BALLAST	TK MI	8.88	\$27,754.00	\$246,455.52
	REPLACE GRADE CROSSING	EA	6	\$58,000.00	\$348,000.00
	REMOVE TRACK	LF	800	\$6.15	\$4,920.00
	DEERING RUNAROUND	LS	1	\$50,000.00	\$50,000.00
	REMOVE TURNOUT	LS	1	\$13,578.00	\$13,578.00
	REMOVE/RELOCATE POLE LINE	LS	1	\$15,000.00	\$15,000.00
	EMBANKMENT IMPROVEMENTS	LS	1	\$100,000.00	\$100,000.00
	FENCING	LF	1700	\$15.00	\$25,500.00
	IMPROVEMENTS BR. 4.50	LS	1	\$140,705.00	\$140,705.00
	INSTALL CRASH WALLS	EA	2	\$12,705.00	\$25,410.00
	UNDERCUT BR. 8.89	LF	800	\$80.00	\$64,000.00

TRACK TOTAL: \$9,970,840.40

SIGNAL PAY ITEMS

ITEM NO.	DESCRIPTION	MATERIAL	LABOR	EQUIPMENT	TOTAL
	ELECTRIC LOCK 1.92 (B&M)	\$34,945	\$17,722	\$2,605	\$55,272
	ELECTRIC LOCK 2.11 (DEERING RUNAROUND)	\$34,945	\$17,722	\$2,605	\$55,272
	INDEPENDENT CEMENT PRIVATE CROSSING (EL 2.45)	\$132,863	\$46,066	\$12,570	\$191,499
	ELECTRIC LOCK 2.70 (NAPPI)	\$34,945	\$17,722	\$2,605	\$55,272
	ELECTRIC LOCK 2.701 (INDEPENDENT CEMENT)	\$34,945	\$17,722	\$2,605	\$55,272
	HASCELL AND HALL PRIVATE CROSSING	\$107,486	\$30,192	\$9,195	\$146,873
	SIGNAL 2.8-2.9 ELECTRIC LOCK 2.88 (OIL TRACK)	\$112,759	\$52,873	\$15,275	\$180,907
	LUNT RD - SIGNAL 5.2-5.3	\$184,029	\$50,788	\$12,875	\$247,692
	BUCKNAM RD	\$22,230	\$9,959	\$1,610	\$33,799
	JOHNSON RD	\$101,065	\$30,192	\$9,195	\$140,452
	CP 7 INTERLOCKING	\$287,877	\$441,070	\$42,878	\$771,825
	CP 10 INTERLOCKING	\$287,877	\$441,070	\$42,878	\$771,825
	STATE GARAGE CROSSING	\$105,745	\$30,192	\$9,195	\$145,132

SIGNAL TOTAL: \$2,851,092.00

MISC. PAY ITEMS

ITEM NO.	DESCRIPTION	UNIT	QUANTITY	UNIT PRICE	TOTAL
	ROADWAY APPROACH GRADE IMPROVEMENTS	LS	4	\$56,000.00	\$224,000.00
	DRAINAGE - VERANDA ST. AREA	LS	1	\$78,000.00	\$78,000.00
	DRAINAGE - BOX CULVERT	LS	1	\$22,500.00	\$22,500.00
	BRIDGE IMPROVEMENTS - PRESUMPCOT RIVER	LS	1	\$1,600,000.00	\$1,600,000.00
	3 MI PASSING SIDING	LS	1	\$1,240,000.00	\$1,240,000.00

MISC. TOTAL: \$3,164,500.00

NOTES:

1. See Feasibility Report for Cost Assumptions

SUBTOTAL: \$15,986,432.40
10% Contingency: \$1,598,643.24
TOTAL: \$17,585,075.64
SAY: \$17,590,000

LINK 8

SLR, Proposed Yarmouth Station @ I295, Exit 15 to Yarmouth Junction

Portland Commuter Rail Study PIN 9503.20



PRELIMINARY ENGINEER'S ESTIMATE
November 14, 2005

TRACK PAY ITEMS

ITEM NO.	DESCRIPTION	UNIT	QUANTITY	UNIT PRICE	TOTAL
	INSTALL TIES	EA	1518	\$90.00	\$136,620.00
	INSTALL 115# CWR (Rail)	TK MI	1.73	\$475,085.00	\$821,897.05
	SURFACE TRACK 2 PASS 4" LIFT	MI	1.73	\$39,266.00	\$67,930.18
	INSTALL #10 TURNOUT	EA	1	\$85,000.00	\$85,000.00
	DITCH TRACK	TK MI	0.69	\$29,520.00	\$20,368.80
	BRUSH CUT	TK MI	1.73	\$7,825.00	\$13,537.25
	CLEAN SHOULDER BALLAST	TK MI	1.73	\$27,754.00	\$48,014.42
	REPLACE GRADE CROSSING	EA	5	\$58,000.00	\$290,000.00
	FENCING	LF	1500	\$15.00	\$22,500.00
	HANCOCK LUMBER	LS	1	\$16,737.00	\$16,737.00
	IMPROVEMENTS BR. 11.66	LS	1	\$60,110.00	\$60,110.00

TRACK TOTAL: \$1,582,714.70

SIGNAL PAY ITEMS

ITEM NO.	DESCRIPTION	MATERIAL	LABOR	EQUIPMENT	TOTAL
	PORTLAND ST	\$134,094	\$39,921	\$11,495	\$185,510
	CLEAVES ST	\$111,237	\$32,257	\$10,345	\$153,839
	ELECTRIC LOCK 11.3 (LUMBER CO)	\$34,945	\$17,722	\$2,605	\$55,272
	MAIN ST	\$23,166	\$9,959	\$1,610	\$34,735
	MILL ST	\$105,745	\$30,192	\$9,195	\$145,132
	ELM ST	\$120,799	\$33,404	\$10,345	\$164,548
	RIVER BEND RD	\$119,919	\$33,404	\$10,345	\$163,668

SIGNAL TOTAL: \$902,704.00

MISC. PAY ITEMS

ITEM NO.	DESCRIPTION	UNIT	QUANTITY	UNIT PRICE	TOTAL
	ROADWAY APPROACH GRADE IMPROVEMENTS	LS	1	\$56,000.00	\$56,000.00
	DRAINAGE - 30" CMP	LF	75	\$170.00	\$12,750.00
	BRIDGE REPLACEMENT - ROYAL RIVER	LS	1	\$1,420,000.00	\$1,420,000.00

NOTES:

MISC. TOTAL: \$1,488,750.00

1. See Feasibility Report for Cost Assumptions

SUBTOTAL: \$3,974,168.70
10% Contingency: \$397,416.87
TOTAL: \$4,371,585.57

SAY: \$4,370,000

LINK 9

Guilford, Yarmouth Junction to Proposed Brunswick Station, Main Street

Portland Commuter Rail Study PIN 9503.20



PRELIMINARY ENGINEER'S ESTIMATE
November 14, 2005

TRACK PAY ITEMS

ITEM NO.	DESCRIPTION	UNIT	QUANTITY	UNIT PRICE	TOTAL
	INSTALL TIES	EA	14340	\$90.00	\$1,290,600.00
	INSTALL 115# CWR (Rail)	TK MI	14.34	\$452,461.00	\$6,488,290.74
	SURFACE TRACK 2 PASS 4" LIFT	MI	14.34	\$39,266.00	\$563,074.44
	INSTALL #10 TURNOUT	EA	6	\$85,000.00	\$510,000.00
	INSTALL #15 TURNOUT	EA	2	\$130,000.00	\$260,000.00
	UPGRADE TK 4 RUNAROUND	LS	1	\$95,000.00	\$95,000.00
	RELOCATE TK 3 RUNAROUND	TK FT	2300	\$104.81	\$241,063.00
	DITCH TRACK	TK MI	5.74	\$29,520.00	\$169,444.80
	BRUSH CUT	TK MI	14.34	\$7,825.00	\$112,210.50
	CLEAN SHOULDER BALLAST	TK MI	14.34	\$27,754.00	\$397,992.36
	REPLACE GRADE CROSSING	EA	16	\$64,000.00	\$1,024,000.00
	REMOVE TRACK	LF	2300	\$6.15	\$14,145.00
	FENCING	LF	3200	\$15.00	\$48,000.00
TRACK TOTAL:					\$11,213,820.84

SIGNAL PAY ITEMS

ITEM NO.	DESCRIPTION	MATERIAL	LABOR	EQUIPMENT	TOTAL
	YARMOUTH JCT INTERLOCKING (see note 6)	\$392,228	\$563,207	\$51,128	\$1,006,563
	EAST ELM STREET (NORTH ELM)	\$141,515	\$41,227	\$10,345	\$193,087
	ELECTRIC LOCK 2.3 (WINE TRACK)	\$34,945	\$17,722	\$2,605	\$55,272
	LOW ROAD (NORTH ROAD)	\$141,515	\$41,227	\$10,345	\$193,087
	SIGNAL 3.8-3.9	\$94,951	\$41,899	\$14,125	\$150,975
	WEBSTER ROAD	\$105,745	\$30,192	\$9,195	\$145,132
	SIGNAL 6.0-6.1	\$94,951	\$41,899	\$14,125	\$150,975
	PORTER ROAD (HUNTER ROAD)	\$141,515	\$41,227	\$10,345	\$193,087
	WEST STREET	\$105,745	\$30,192	\$9,195	\$145,132
	BOW STREET	\$141,515	\$41,227	\$10,345	\$193,087
	SCHOOL STREET	\$105,745	\$30,192	\$9,195	\$145,132
	EAST STREET - SIGNAL 8.0-8.1	\$145,296	\$41,701	\$11,725	\$198,722
	UPPER MAST LANDING ROAD (MAST HEAD LANDIN	\$105,745	\$30,192	\$9,195	\$145,132
	HALL ROAD	\$105,745	\$30,192	\$9,195	\$145,132
	SIGNAL 10.4-10.5	\$94,951	\$41,899	\$14,125	\$150,975
	BUNGANUC ROAD	\$105,745	\$30,192	\$9,195	\$145,132
	HILLSIDE ROAD - SIGNAL 12.6-12.7	\$145,296	\$41,701	\$11,725	\$198,722
	CHURCH ROAD - SIGNAL 15.0-15.1	\$184,029	\$50,788	\$12,875	\$247,692
	ELECTRIC LOCK 15.3	\$34,945	\$17,722	\$2,605	\$55,272
	ELECTRIC LOCK 15.5	\$34,945	\$17,722	\$2,605	\$55,272
	STANWOOD STREET	\$164,915	\$47,498	\$12,875	\$225,288
	UNION STREET - ELECTRIC LOCK 16.10	\$167,227	\$56,903	\$15,480	\$239,610
	STATION SIGNAL	\$94,951	\$41,899	\$14,125	\$150,975
	ELECTRIC LOCK (RELOCATED RUNAROUND)	\$34,945	\$17,722	\$2,605	\$55,272
	ELECTRIC LOCK (RELOCATED RUNAROUND)	\$34,945	\$17,722	\$2,605	\$55,272
SIGNAL TOTAL:					\$4,639,997.00

Portland Commuter Rail Study
PIN 9503.20



PRELIMINARY ENGINEER'S ESTIMATE
November 14, 2005

MISC. PAY ITEMS

ITEM NO.	DESCRIPTION	UNIT	QUANTITY	UNIT PRICE	TOTAL
	ROADWAY APPROACH GRADE IMPROVEMENTS	LS	8	\$56,000.00	\$448,000.00
	DRAINAGE	LS	1	\$70,000.00	\$70,000.00
	STONE ARCH REPAIRS	LS	6	\$50,000.00	\$300,000.00

NOTES:

MISC. TOTAL: \$818,000.00

1. See Feasibility Report for Cost Assumptions

SUBTOTAL: \$16,671,817.84
15% Contingency: \$2,500,772.68
TOTAL: \$19,172,590.52

SAY: \$19,170,000

LINK 10

SLR, Yarmouth Junction to Auburn Intermodal Facility

Portland Commuter Rail Study PIN 9503.20



PRELIMINARY ENGINEER'S ESTIMATE
November 14, 2005

TRACK PAY ITEMS

ITEM NO.	DESCRIPTION	UNIT	QUANTITY	UNIT PRICE	TOTAL
	INSTALL TIES	EA	17130	\$90.00	\$1,541,700.00
	INSTALL 115# CWR (Rail)	TK MI	17.13	\$475,085.00	\$8,138,206.05
	SURFACE TRACK 2 PASS 4" LIFT	MI	17.13	\$39,266.00	\$672,626.58
	INSTALL 115# CWR TRACK	FT	2200	\$170.00	\$374,000.00
	INSTALL #10 TURNOUT	EA	10	\$85,000.00	\$850,000.00
	INSTALL #15 TURNOUT	EA	1	\$130,000.00	\$130,000.00
	INSTALL DIAMOND	EA	2	\$175,000.00	\$350,000.00
	UPGRADE 252 RUNAROUND	LF	2100	\$20.00	\$42,000.00
	UPGRADE POWNAL SPUR	LF	430	\$20.00	\$8,600.00
	UPGRADE 231 RUNAROUND	LF	2300	\$20.00	\$46,000.00
	UPGRADE DANVILLE YD (adj tk)	LS	2300	\$20.00	\$46,000.00
	DITCH TRACK	TK MI	6.85	\$29,520.00	\$202,212.00
	BRUSH CUT	TK MI	17.13	\$7,825.00	\$134,042.25
	CLEAN SHOULDER BALLAST	TK MI	17.13	\$27,754.00	\$475,426.02
	REPLACE GRADE CROSSING	EA	20	\$54,000.00	\$1,080,000.00
	OPEN DECK BRIDGE TIMBER	EA	373	\$525.00	\$195,825.00
	REMOVE TRACK	LF	0	\$6.15	\$0.00
	FENCING	LF	3200	\$15.00	\$48,000.00

TRACK TOTAL: \$14,334,637.90

SIGNAL PAY ITEMS

ITEM NO.	DESCRIPTION	MATERIAL	LABOR	EQUIPMENT	TOTAL
	YARMOUTH JCT INTERLOCKING (see note 6)	\$236,003	\$434,646	\$40,128	\$710,777
	ELECTRIC LOCK 12.17 (RUNAROUND)	\$34,945	\$17,722	\$2,605	\$55,272
	ELECTRIC LOCK 12.71 (RUNAROUND)	\$34,945	\$17,722	\$2,605	\$55,272
	OLD FIELD RD	\$141,515	\$41,227	\$10,345	\$193,087
	DEER RUN ROAD	\$105,745	\$30,192	\$9,195	\$145,132
	BLUEBERRY FIELDS (PRIVATE?)	\$105,745	\$30,192	\$9,195	\$145,132
	FARM EDGE ROAD	\$105,745	\$30,192	\$9,195	\$145,132
	NORTH ROAD - SIGNAL 14.2-14.3 (SKILLINGS)	\$184,029	\$50,788	\$12,875	\$247,692
	NORTH ROAD (SAWYERS)	\$141,515	\$41,227	\$10,345	\$193,087
	MEMORIAL HIGHWAY ROUTE 9 (DUNNS)	\$141,515	\$41,227	\$10,345	\$193,087
	NORTH ROAD (BRIDGE RD)	\$141,515	\$41,227	\$10,345	\$193,087
	SIGNAL 16.0-16.1	\$94,951	\$41,899	\$14,125	\$150,975
	CLUFF ROAD	\$105,745	\$30,192	\$9,195	\$145,132
	MILLIKEN ROAD	\$141,515	\$41,227	\$10,345	\$193,087
	ELECTRIC LOCK 18.31 (INDUSTRY)	\$34,945	\$17,722	\$2,605	\$55,272
	DEPOT ROAD - SIGNAL 18.4-18.5	\$145,296	\$41,701	\$11,725	\$198,722
	SIGNAL 20.4-20.5	\$94,951	\$41,899	\$14,125	\$150,975
	INTERVALE ROAD ROUTE 231 - SIGNAL 22.4-22.5	\$184,029	\$50,788	\$12,875	\$247,692
	COBBS RIDGE ROAD - SIGNAL 24.4-24.5	\$184,029	\$50,788	\$12,875	\$247,692
	SIGNAL 26.3-26.4	\$94,951	\$41,899	\$14,125	\$150,975
	ELECTRIC LOCK 26.85 (LONG CROSSOVER TO GUIL)	\$34,945	\$17,722	\$2,605	\$55,272
	ELECTRIC LOCK 26.95 (YARD LEAD)	\$34,945	\$17,722	\$2,605	\$55,272
	ELECTRIC LOCK 27.35 (YARD LEAD)	\$34,945	\$17,722	\$2,605	\$55,272
	DANVILLE JCT	\$236,003	\$434,646	\$40,128	\$710,777
	DANVILLE ROAD	\$141,515	\$41,227	\$10,345	\$193,087
	ELECTRIC LOCK 27.6 (RUNAROUND)	\$34,945	\$17,722	\$2,605	\$55,272
	ELECTRIC LOCK 28.1 (RUNAROUND)	\$34,945	\$17,722	\$2,605	\$55,272

**Portland Commuter Rail Study
PIN 9503.20**



**PRELIMINARY ENGINEER'S ESTIMATE
November 14, 2005**

HOTEL ROAD	\$141,515	\$41,227	\$10,345	\$193,087
ELECTRIC LOCK 29.05 (INDUSTRY)	\$34,945	\$17,722	\$2,605	\$55,272
AIRPORT JCT	\$287,877	\$441,070	\$42,878	\$771,825
KITTY HAWK AVE	\$141,515	\$41,227	\$10,345	\$193,087
STATION SIGNAL	\$80,326	\$41,899	\$14,125	\$136,350

SIGNAL TOTAL: \$6,347,124.00

STRUCTURAL REHABILITATION PAY ITEMS

ITEM NO.	DESCRIPTION	UNIT	QUANTITY	UNIT PRICE	TOTAL
	Royal River, TPT Open Deck	LF	128	\$11,000	\$1,408,000
	Royal River, TRT Open Deck	LF	114	\$11,000	\$1,248,500
	Farm Rd, IBMS Open Deck	LF	17	\$15,000	\$255,000
	Allen Rd, IBMS Open Deck	LF	24	\$15,000	\$352,500
	Farm Rd, IBMS Open Deck	LF	15	\$15,000	\$225,000
	Meadow Brook, IBMS Open Deck	LF	24	\$15,000	\$360,000
	Royal River, TPG Open Deck	LF	64	\$7,000	\$446,250
	Royal River, TPG Open Deck	LF	64	\$7,000	\$446,250
	Royal River, TPG Open Deck	LF	65	\$7,000	\$457,940
	Royal River, DPG Open Deck	LF	44	\$7,000	\$308,000
	Abandoned Rd, TPG Ballasted Deck	LF	29	\$15,000	\$439,950

MISC. TOTAL: \$5,947,390.00

MISC. PAY ITEMS

ITEM NO.	DESCRIPTION	UNIT	QUANTITY	UNIT PRICE	TOTAL
	ROADWAY APPROACH GRADE IMPROVEMENTS	LS	10	\$56,000.00	\$560,000.00
	DRAINAGE	LS	1	\$100,000.00	\$100,000.00

MISC. TOTAL: \$660,000.00

NOTES:

- See Feasibility Report for Cost Assumptions

SUBTOTAL: \$27,289,151.90
15% Contingency: \$4,093,372.79
TOTAL: \$31,382,524.69

SAY: \$31,380,000

LINK 11

Proposed Union Branch connection to Portland Waterfront RR

Portland Commuter Rail Study PIN 9503.20



PRELIMINARY ENGINEER'S ESTIMATE
November 14, 2005

TRACK PAY ITEMS

ITEM NO.	DESCRIPTION	UNIT	QUANTITY	UNIT PRICE	TOTAL
	INSTALL 115# CWR TRACK, TIES, STONE, ETC	TK FT	2150	\$170.00	\$365,500.00
	INSTALL #15 TURNOUT	EA	1	\$130,000.00	\$130,000.00
TRACK TOTAL:					\$495,500.00

MISC. PAY ITEMS

ITEM NO.	DESCRIPTION	UNIT	QUANTITY	UNIT PRICE	TOTAL
	COMMON EXCAVATION	CY	7,500	\$12.75	\$95,625.00
	DRAINAGE - CATCH BASINS	EA	10	\$2,400.00	\$24,000.00
	DRAINAGE - PIPES/UNDERDRAIN	LF	2,300	\$55.00	\$126,500.00
	CHAIN LINK FENCE	LF	2,300	\$15.00	\$34,500.00
	RETAINING WALLS	SF	27,000	\$28.50	\$769,500.00
	BIKE PATH	SF	10,000	\$11.00	\$110,000.00
	HEAVY RIPRAP	CY	1,600	\$55.00	\$88,000.00
	RIGHT-OF-WAY - PROPERTY ACQUISITION	LS	1	\$75,000.00	\$75,000.00
MISC. TOTAL:					\$1,323,125.00

NOTES:

1. See Feasibility Report for Cost Assumptions

SUBTOTAL: \$1,818,625.00
15% Contingency: \$272,793.75
TOTAL: \$2,091,418.75

SAY: \$2,090,000

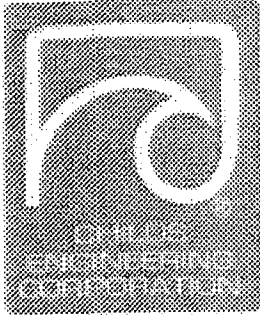

CHILDS ENGINEERING CORPORATION

BOX 3032 MEDFIELD, MASSACHUSETTS 02052 508/258-8943 FAX 508/359-8751

Kenneth M. Childs, Jr., P.E.
Owner/President

David N. Pomeroy, P.E.
President

David G. Bernier, P.E.
Vice President

25 October 2005

Mr. Donald Ettinger
HNTB Corporation
2 Thomas Drive
Westbrook, ME. 04902

Re: Back Cove Railroad Bridge Inspection

Dear Mr. Ettinger:

Childs Engineering is pleased to present the findings on our inspection of the Back Cove Railroad Bridge. The scope of work is limited to the three (3) concrete and granite piers and nine (9) trestle bents. The remaining trestle bents that are underwater at mean low water were inspected by a "swim by" inspection. The objective of the investigation is to identify and document the condition of the submerged components of the piers such that plans could be developed for repair of the found deficiencies. The following report includes the results of our inspection with sketches and photographs to illustrate the conditions found.

Scope of Work

On October 20 and 21, a crew from Childs Engineering performed an in-depth inspection of the Back Cove Railroad Bridge. The assembled three person crew (two divers and one topside) inspected the submerged sections of three granite and concrete piers as well as nine predetermined bents previously located by HNTB. The crew also did a general assessment (i.e. swim by) of the remaining bents which are still covered at low tide.

Inspection Procedure

Using a 14' John boat, two divers, fully outfitted with SCUBA equipment including a top side communicating device, underwater camera, a D-meter, and a number of smaller miscellaneous hand tools performed the inspection. A top-side support person was responsible for recording all descriptive underwater notes as well as observing all weather and tide conditions. All notes were logged in a standard field note book. The underwater inspection of the three piers was done by stationing the perimeter of each pier to establish reference points.. Soundings were taken with a lead line at multiple points on all three piers.

This process not only allowed the crew to accurately report their findings to a stations mark, but to an elevation as well, giving the crew the ability to know their locations at all times. All detailed information was recorded and logged. Many typical and unusual conditions were photographed to further help and support this report and the rehabilitation process of the Back Cove Railroad Bridge.

The timber pile bents of the trestle structure were numbered beginning at the concrete piers and heading inshore in both directions. These bent numbers were designated N for north and S for south. The first 9 bents of the trestle to the north of the piers received a 100% visual examination with band cleaning on at least one pile per bent. The remaining piles on the north side were inspected by "swim by" to establish general conditions of areas below MLW. On the south side of the trestle all piles received a "swim by" examination of areas below MLW.

Description of Structure

The Back Cove Railroad Bridge is made-up of three 3 concrete and granite piers. As no classification differentiating these three piers was given, we designated them as North, South, and Center piers (see sheet number M-04).

The North Pier: The original superstructure of the North Pier was constructed from granite blocks. At some point, to help reinforce the granite blocks a sheet pile wall was driven around the perimeter to act as a form. Concrete and rebar were placed between the sheet pile and the blocks to shore up the multiple courses of granite blocks.

The South Pier: The original superstructure of the South Pier was constructed from granite blocks. At some point, to help reinforce the granite blocks a sheet pile wall was driven around the perimeter to act as a form. Concrete and rebar were placed between the sheet pile and the blocks to shore up the multiple courses of granite blocks. The South Pier also has 6 steel H-piles located on the north face, three on each side of the centerline. These piles provide support to the swing bridge when in the closed position.

The Center Pier granite blocks are in a circular pattern. At a later date repairs were made by setting steel forms around the perimeter of the blocks in the shape of an octagon. The steel forms extend down below MLW approximately 5 feet. From the bottom of the forms to the mudline the granite blocks are exposed (typically 2 courses). The forms were filled with reinforced concrete to make a protective girdle around the granite blocks.

The nine (9) trestle bents identified by HNTB for close examination, were

found to have contained six to eight timber piles and two to four were battered piles. Vertical piles are label A through D and battered piles labeled as 1, 1A, 2 and 2A as needed (for labeling see sheet M-01). Each pile bent has horizontal and diagonal bracing. The trestle superstructure is constructed of heavy timbers.

Inspected Conditions

The South Pier (see sheet M-04)

The South Pier measures 54 feet long tip to tip and is 27.5 feet wide. The steel sheet piling has large corrosion holes at various points around this pier ranging from one to two feet in diameter above and below mean low water (see photo #1). The sheet pile does have some larger holes starting at mean low water at station 0+18; this is where the holes are 4 feet in width and, in some locations, run down to the mudline. Sheet pile thickness readings were taken at station 0+10, the south west corner. The readings were: .205 of an inch at mean high water; .165 inches at mean low water; and .215 at the mudline (see photo # 2).

The concrete displays consistent signs of deterioration, having large voids and, in most cases, missing 3-4 inches of material at all exposed locations. Remaining concrete is hard when hit with a hammer. In the area of missing concrete the reinforcing steel is exposed. The pier at the present time appears stable (see photo # 3). The core of this pier was made of granite blocks, at this time they are not exposed. During this inspection no major geometric anomalies were noted (i.e. rotation)

The six H-piles located on the North face that supports the swing bridge show severe corrosion through the tidal zone amounting to a 95% loss in cross sectional area of all the H-piles.

The Center Pier (see sheet M-04)

The steel form on the Center Pier is mostly gone due to long term effect of salt water corrosion (see photo # 4).

The concrete girdle displays consistent signs of deterioration with large voids, in most cases; 6 to 12+ inches deep at all exposed locations. Where there are voids the reinforcing steel is exposed.

The Center Pier has two courses of granite blocks are exposed below the concrete girdle. One block on the Northeast face of the pier is cracked in half (see photo # 5). On the Northeast face the block joints on the first course of block below the girdle have opened a maximum of 2 1/2". Typically, the blocks and joints are in good shape (see photo # 6).

The pier at present time appears stable and does not exhibit any

geometric anomalies.

The North Pier (see sheet M-04)

The North Pier measures 54 feet long tip to tip and 27.5 feet wide. On the Northeast face of the pier the sheet pile has large corrosion holes. These holes are 5 to 6 feet in length starting at mean low water. On the South side of the pier the sheet pile flanges exhibit 100% loss of cross section area due to corrosion. The sheet pile along the Southeast face has separated from the interior concrete by as much as 6". At station 1+07, the sheet pile has some larger holes starting at mean low water mark on the Northeast face. This is where the holes grow to 4 feet in width and, in some locations, run down to the mudline. The sheet pile thickness readings at station 0+18 are: .250 inches at mean low water; .150 inches at mean high water; and .150 inches at the mud line (see photo # 7).

The concrete displays consistent signs of deterioration with large voids, in most cases, missing 3-4 inches of material at all exposed locations. Remaining concrete is hard when hit with hammer. In these areas the reinforcing steel is exposed.

The pier at present time appears stable and does not exhibit any geometric anomalies (see photo # 8).

North side timber Bents 1N – 9N

The typical pile arrangement of the bents selected for close examination consist of 8 piles, the outside two of each end being battered (see sheet M-03). The bracing is made-up of two horizontal braces located at mean low water and two cross braces running from the pile cap on the outside end to the battered piles on the opposite side. All piles were commonly covered with light to heavy marine growth.

The typical conditions found were: active marine borers; light ice damage; splits; and corroded fasteners. Piles typically have minimum diameters of 12 inches. Marine borer damage, is the decrease of cross section eating away of the wooden piles by marine organisms in this case *Limnoria*. If left untreated the damage can become large enough to have structural implications. Ice damage, is damage occurring as ice forms in the outer fibers of the piles. As the ice freezes on the piles it expands, delaminating the outer timber fibers of the pile. Also ice flows can cause high stress in the piles and bracing as the trestle structure blocks their movement. This will result in split piles and abraded areas on the piles and bracing.

Bent 1, Piles 1A and 2A, although the horizontal bracing is still in place all the connection bolts are completely corroded though and no longer securely fasten the bracing to the structure. Pile 1A has marine borer damage, located at the horizontal bracing. The rest of the piles look to be in good condition.

Page 5 of 14

Bent 2, the horizontal bracing has a split along on the inshore side of the bent. All of the piles are in good condition with a consistent $\frac{1}{4}$ " of ice damage on the outside.

Bent 3, Pile 2 has a 1 inch wide by 4 feet long split, located at the horizontal bracing and shows signs of marine borer damage four inches deep (see photo # 9). Pile D has a 3' split located at the horizontal bracing that runs all the way through the pile. Pile A has marine borer damage about 18" in length by 3" deep at the horizontal bracing (see photo # 10). All connection bolts at mean low water, are severely corroded, or gone and no longer fastening the bracing to the pile.

Bent 4, Pile 2A is no longer fixed to the pile cap. Pile D is a split, at the low horizontal bracing. Horizontal bracing on the south side is not attached to pile 2 and the north side is not attached to piles A and 1.

Bent 5, Pile D has a split 1" wide by 1' long located at mean low water, similar to bent 3, pile D. Pile 5 has an 18" long by 4" wide hole. Both horizontal braces are no longer there.

Bent 6, Piles 2A, 2, and D have ice damage around the perimeter at the mean low water. Both horizontal braces and cross braces are no longer connected.

Bent 7 has nine piles supporting the trestle. Pile 1B is displaying heavy ice damage around the perimeter, roughly 1" deep. Piles 1A, A, and D have marine borer damage approximately 4" long by 2" deep in multiple locations. All piles still have a remaining effective diameter of 10". No horizontal bracing was found at this bent.

Bent 8, pile 2A is no longer fastened to the pile cap. All horizontal bracing is missing from this bent.

Bent 9, pile 1A has light marine bore active approximately 1" deep all the way around the perimeter. The pile still exceeds 12 inches in diameter. This bent has no horizontal bracing. Pile 2A is no longer fastened to the pile cap.

All remaining timber bents inspected on North bound side

Bents 10N – 20N, typically have a total of 6 piles, four of which are vertical and 2 battered (see sheet M-02). Splits are noted on most piles at the horizontal bracing elevation. The horizontal bracing is noted as missing or only partially fastened at most locations. This holds true for both the north and south sides of the piles.

Bent	Pile	Notes
10N	All	Missing all horizontal bracing
11N	2,1	Not fastened to horizontal bracing
	1A	Light marine borer damage at the mud-line
12N	2,2A	Horizontal braces not fastened
	1A, 1	Horizontal braces not fastened
	1A	Light marine borer damage at mud-line
13N		Eight piles
	2,2A	Light marine borer activity at the mud-line. Piles are still 12"+ in diameter
14N		First bent with six piles
15N	2A	Split at mean low water 2' long X ½" wide
16N		No battered pile on the East side
17N	All	In good condition below MLW. Missing all horizontal bracing
18N	All	In good condition below MLW.
19N	2A	Split at mean low water 2' long X ½" wide. Missing all horizontal bracing.
20N	All	Missing all horizontal bracing.
	B	Severe marine borer damage. The condition extends from the mud-line up 2'. The pile also has a 1" split that continues up to MLW from the marine borer damage area.

General conditions for the bents located on South bound side of the Railroad trestle

Bents were originally designed with 6 piles with low water horizontal bracing and cross bracing, one on each side of pile (see sheet M-02). The entire South side has no horizontal bracing or cross bracing or the bracing is hanging from the bolts at the upper connection. The top 6 feet of the all bents are burnt, leaving most piles wild. Other common conditions were light ice damage around the perimeters of all piles at mean low water and light marine borer activity. Typically pile diameters range from 10 to 12 inches. Splits are noted on most piles at the horizontal bracing elevation. Between Bent 13S and Bent 14S there is a rather large bent spacing longer than typical. There are no signs of cut-off piles at the mudline, which would indicate a missing bent.

Bent	Pile	Notes
1S	All	Six piles total. All in good condition below MLW.
2S	All	Six piles total. All in good condition below MLW.
3S	All	Six piles total. All in good condition below MLW.
4S	C	Split 2' long X 1/2" wide at MLW.
5S	All	Six piles total. All in good condition below MLW.
6S	All	Six piles total. All in good condition below MLW.
7S	All	Six piles total. All in good condition below MLW.
8S	1,A,B	Light ice damage 1/2" deep at mean low water. Marine borer activity at the mud-line. Piles are 10" in diameter.
9S	All	Six piles total. All in good condition below MLW.
10S	2	Light ice damage 1/2" deep at MLW.
10S	A	Light ice damage 1/2" deep at mean low water. Light marine borer activity 1/2" deep. Pile 10" in diameter.
11S	1	Light ice damage 1/2" deep at MLW.
12S	2,D	Light ice damage 1/2" deep at MLW.
13S	All	Six piles total. In good condition below MLW.
14S	D	Split at mean low water 2 1/2' long X 1/2" wide
15S	2,B,1	Marine borer at mean low water. Piles 10"+ in diameter.
16S	B,A	Light ice damage 1/4"
	1A	Three splits at mean low water 3' long X 1/2" wide
17S	All	Six piles total. In good condition below MLW.
18S	D	Split at mean low water 12' long X 2" wide. Marine borer activity in the split making split 4" deep.
19S	All	Six piles total. In good condition below MLW.
20S	All	Six piles total. In good condition below MLW.
21S		Pile not connected at the top
22S	All	Seven piles. All in good condition below MLW.
23S	2,D	Light ice damage 1/2" to 1/4" deep at MLW,
	1	Split 4' long X 1/2" wide at MLW.
24S	A	Multiple splits at MLW ranging from 2'-5' long X 1/2" wide.

South Side Bent Conditions Continued

25S	All	Five piles total. Missing batter #2.
26S	All	Six piles total. All in good condition below MLW.
27S	2	Light marine borer damage. Pile is still 12"+ in diameter.
28S	All	Six piles total. All in good condition below MLW.
29S	All	Six piles total. All in good condition below MLW.
30S	All	Six piles total. All in good condition below MLW.
31S	All	Missing batter #2
	C	Ice damage 3/4" deep at MLW.
32S	1	Cut-off pile next to it on the South side running from the mud-line up 8'.
33S	All	Six piles total. All in good condition below MLW.
34S	All	Six piles total. All in good condition below MLW.
35S	All	Six piles total. All in good condition below MLW.
36S	A	Horizontal brace is split on both sides. Light ice damage at MLW.
37S	All	Missing horizontal bracing on the South side
	B	Light ice damage at MLW.
38S	All	No horizontal bracing on the North or South side.
39S	All	Six piles total. All in good condition below MLW.
40S	All	Has lower cross bracing that is hanging
41S	All	Six piles total. All in good condition below MLW.
42S	1	Horizontal bracing is unfastened.
43S	All	Lower cross bracing bolts are corroded-- no longer fastened.
44S	All	Lower cross bracing split on the North and South side. No horizontal bracing.
45S	All	Both lower cross bracings running into the mud-line are split.
46S	All	Both lower cross bracings running into the mud-line are split.
	C,D	Light ice damage at MLW.

Summary

Overall the submerged portions of the structures of the trestle and swing bridge piers are in fair to good condition. It is evident however, that little maintenance has occurred on these structures for a very long time. The piers, while now stable, require significant maintenance in order to stabilize the deterioration of repairs made in the past.

Based on the conditions found during this investigation the swing bridge cannot be used until repairs are made to the support piles on the south pier (steel H-piles).

Page 9 of 14

The repairs made to the granite block piers are in poor condition. The affect of loss of concrete and steel cross section can not be determined at this time, since a majority of the granite blocks are not exposed and their condition cannot be visually determined. A complete review of the designs and reasoning for the additional concrete and steel girdle should be done. This will help determine if these repairs are needed and if so what loading the piers will be able to handle. It's assumed that the repairs were meant to stabilize and protect the original granite block pier, when supporting train loadings.

The timber piles while generally in good condition below MLW and exhibit conditions that require maintenance to insure long term service (load depending). Since there is marine borer activity on some timber piles it is only a matter of time before all the piles are affected. Icing conditions have damaged a large number of timber piles resulting in splits at the lower bolt hole locations. While this is not a serious structural problem now, it has the potential to develop into a structural problem in the future. The splits have opened up the interior of the pile (which is untreated) to marine borer damage. Also there is a loss of lateral stability associated with the split piles.

If you have any questions or wish to discuss the report in further detail please don't hesitate to contact the undersigned.

Respectfully submitted,

Philip Iantosca
Childs Engineering Corp.

Craig Sams
Childs Engineering Corp.

PHOTO APPENDIX

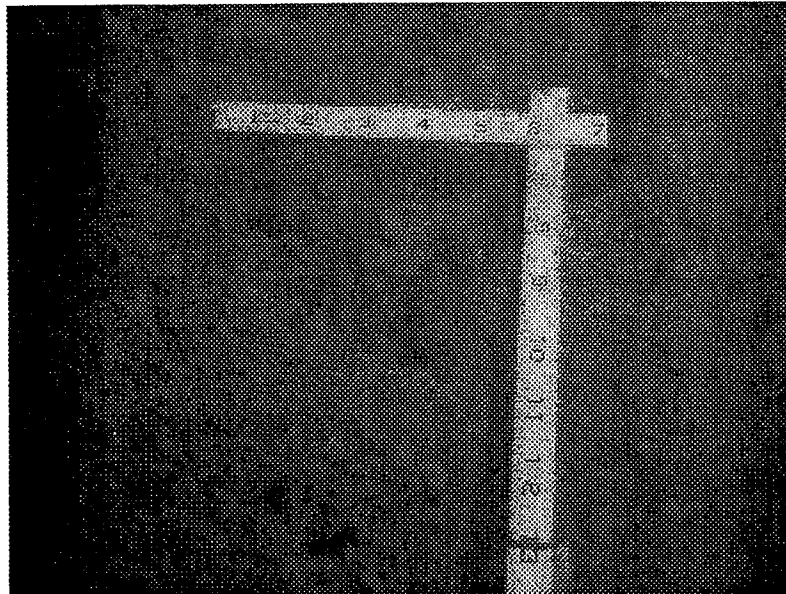

Photo #1, South Pier, 7" wide hole in sheet pile at station 72, at the mudline



Photo # 2 South Pier, Station 10, elevation mean low water, surface cleaned for steel thickness reading



Photo # 3, South pier, Station 18 – 50, general conditions above the water line

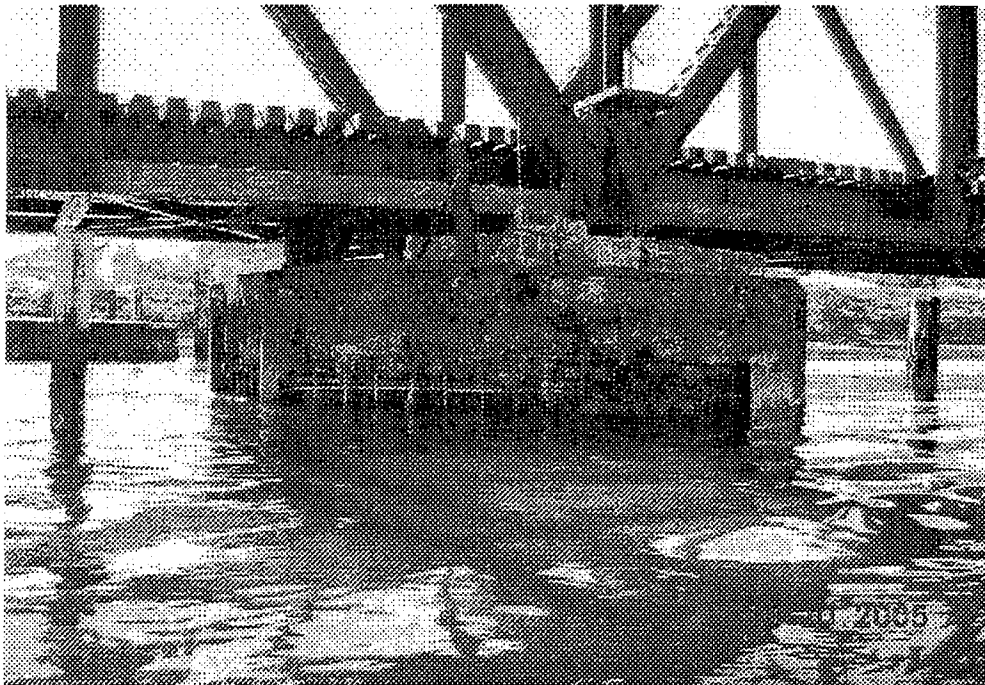

Photo # 4 Center pier, general condition above mean low water

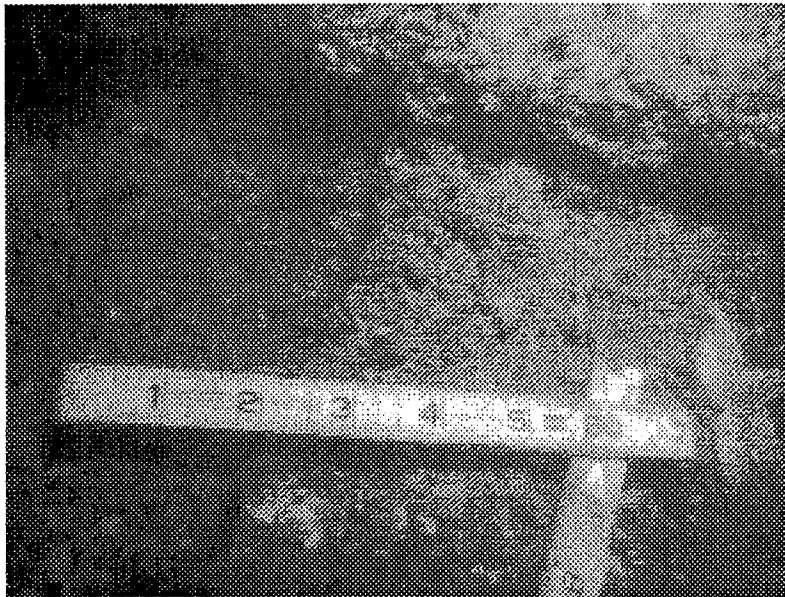

Photo # 5 Center Pier, station 19, crack in granite block



Photo # 6 Center Pier, typical granite block joint open 2 1/2"

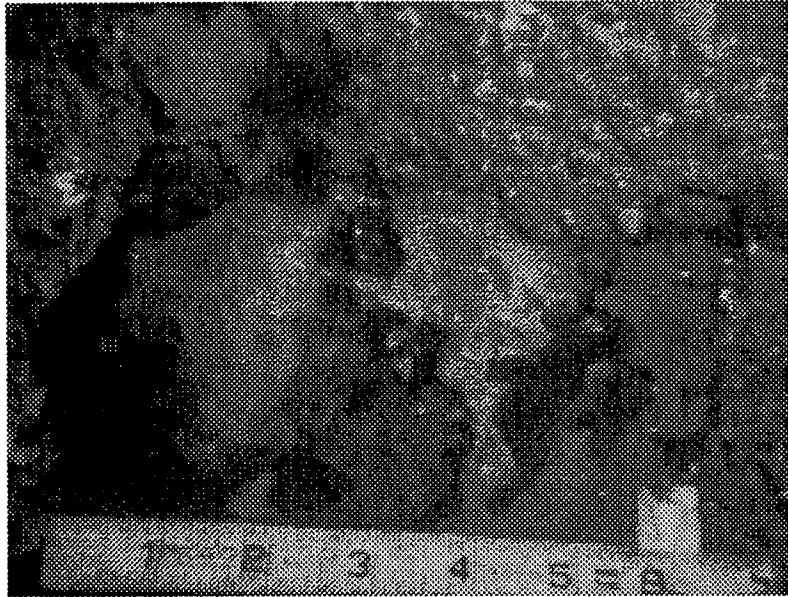

Photo # 7 North Pier, Station 18, elevation mean low water,
Surface cleaned for steel thickness reading



Photo # 8, North Pier, Sheet pile on South east face is separated

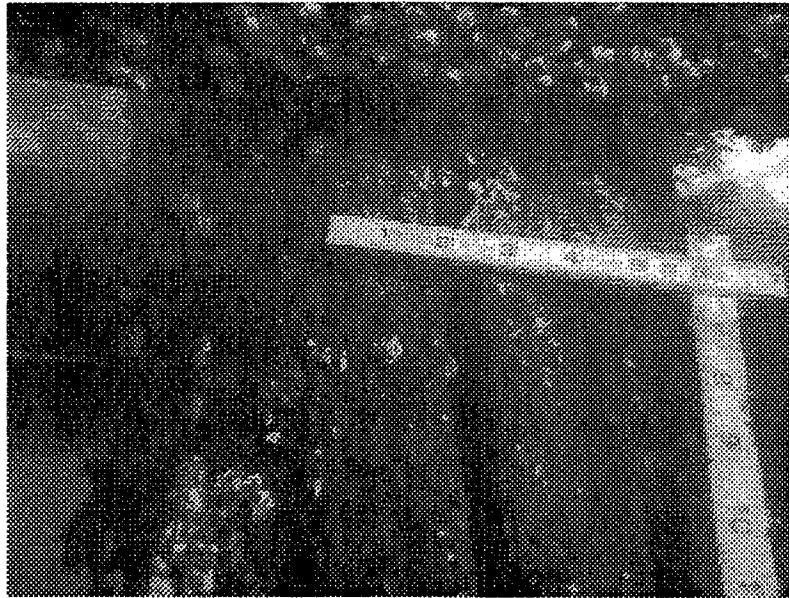

Photo # 9, Bent 3 pile 3, split just below horizontal bracing



Photo 10, Bent 2, pile # 2, split at mean low water

LEGEND

- TIMBER PILE
- TIMBER BATTER PILE
- ⊙ PILE ROW DESIGNATION
- ⊙(40N) PILE BENT DESIGNATION

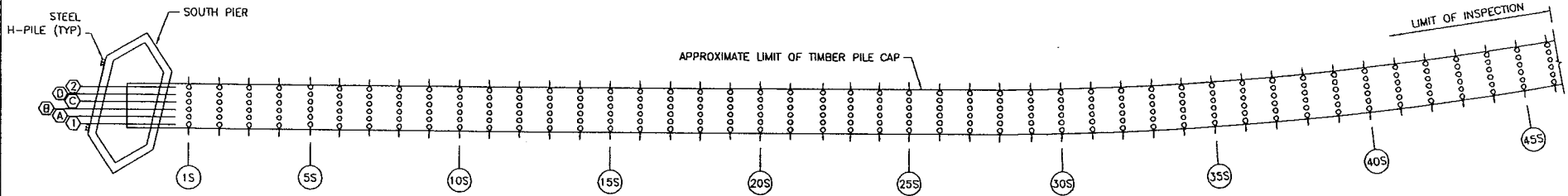

PILE PLAN

SCALE: 1"=40'-0"

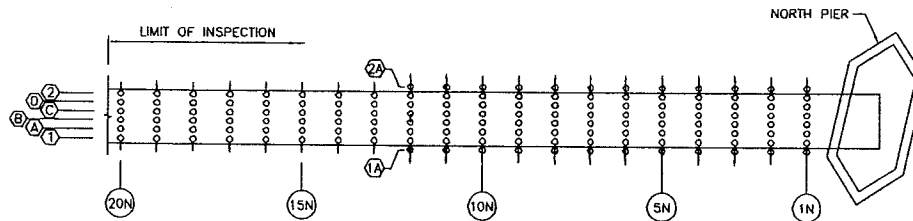

PILE PLAN

SCALE: 1"=40'-0"

NOTE:

- 1.) LOCATION OF PILES ARE APPROXIMATE.
- 2.) PILES OF BENTS 1N TO 9N WERE INSPECTED FULL LENGTH.



CHILDS ENGINEERING CORPORATION

BOX 333 MEDFIELD, MASSACHUSETTS 02052 U.S.A.
 Phone: (508) 359-8945 Fax: (508) 359-2751
 E-mail: mail@childseng.com

Mark	Description	Date	Appr.

Designed by:	PDI	Date:	11/07/05
Drawn by:	APL	Check by:	PDI
		Design file no.:	195505-01
Reviewed by:	CDS	Plot Scale:	1"=0'-1"

BACK COVE RAILROAD BRIDGE INSPECTION
 HNTB CORPORATION
 PORTLAND, ME

PILE PLAN

Sheet reference number:
M-01
 Sheet 1 of 4

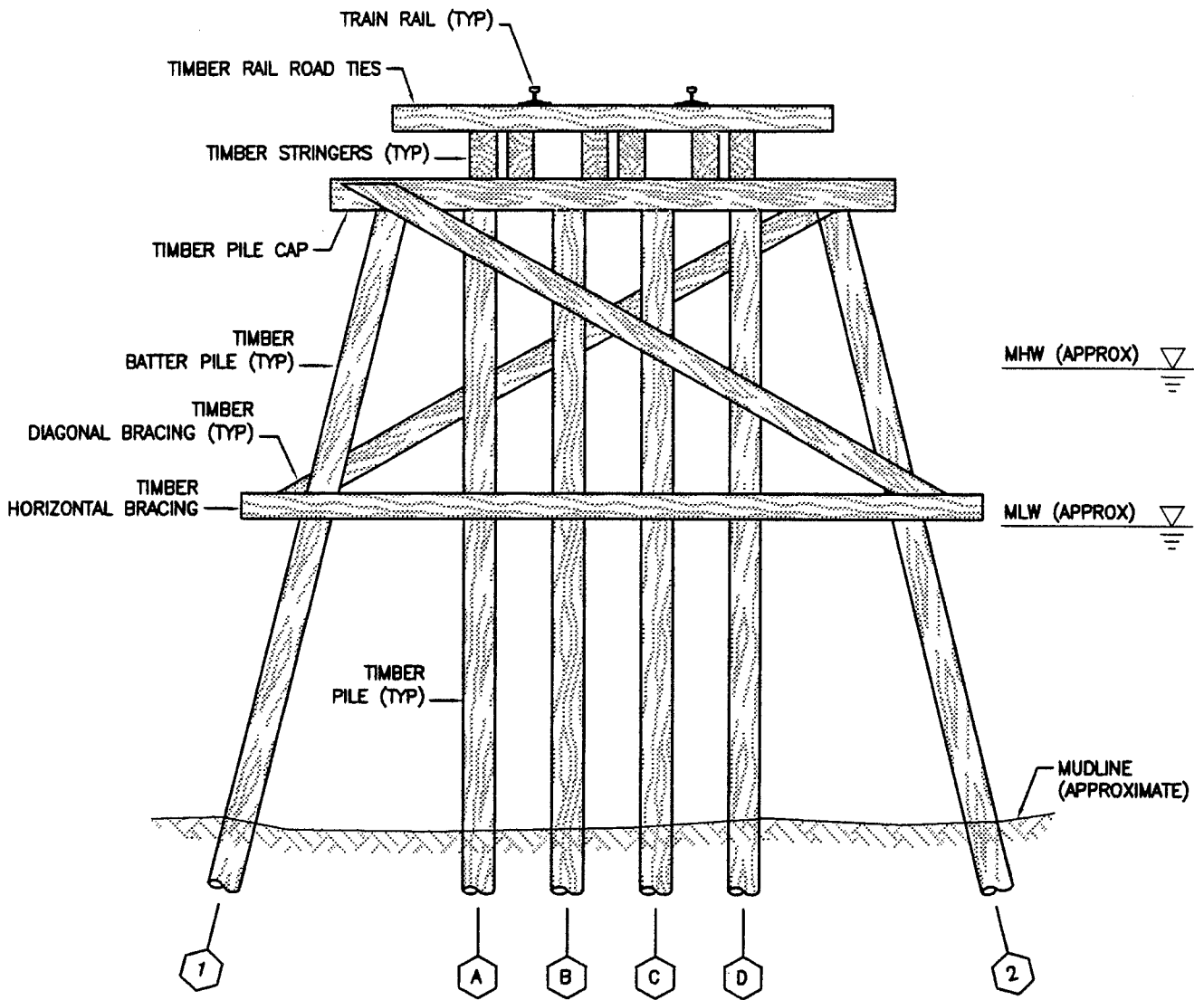

TYPICAL SECTION

SCALE: 3/16" = 1'-0"



CHILDS ENGINEERING CORPORATION
 BOX 333 MEDFIELD, MASSACHUSETTS 02052 U.S.A.
 Phone: (508) 359-8945 Fax: (508) 359-2751
 E-mail: mail@childseng.com

Designed by:		Date:	
PDI		11/07/05	
Own by:	Chk by:	Design file no.	
APL	PDI	195505-02	
Reviewed by:		Plot Scale:	
CDS		1"=0'-1"	

BACK COVE RAILROAD BRIDGE INSPECTION
 HNTB CORPORATION
 PORTLAND, ME

TYPICAL 6 PILE BENT

Sheet
 reference
 number:

M-02
 Sheet 2 of 4

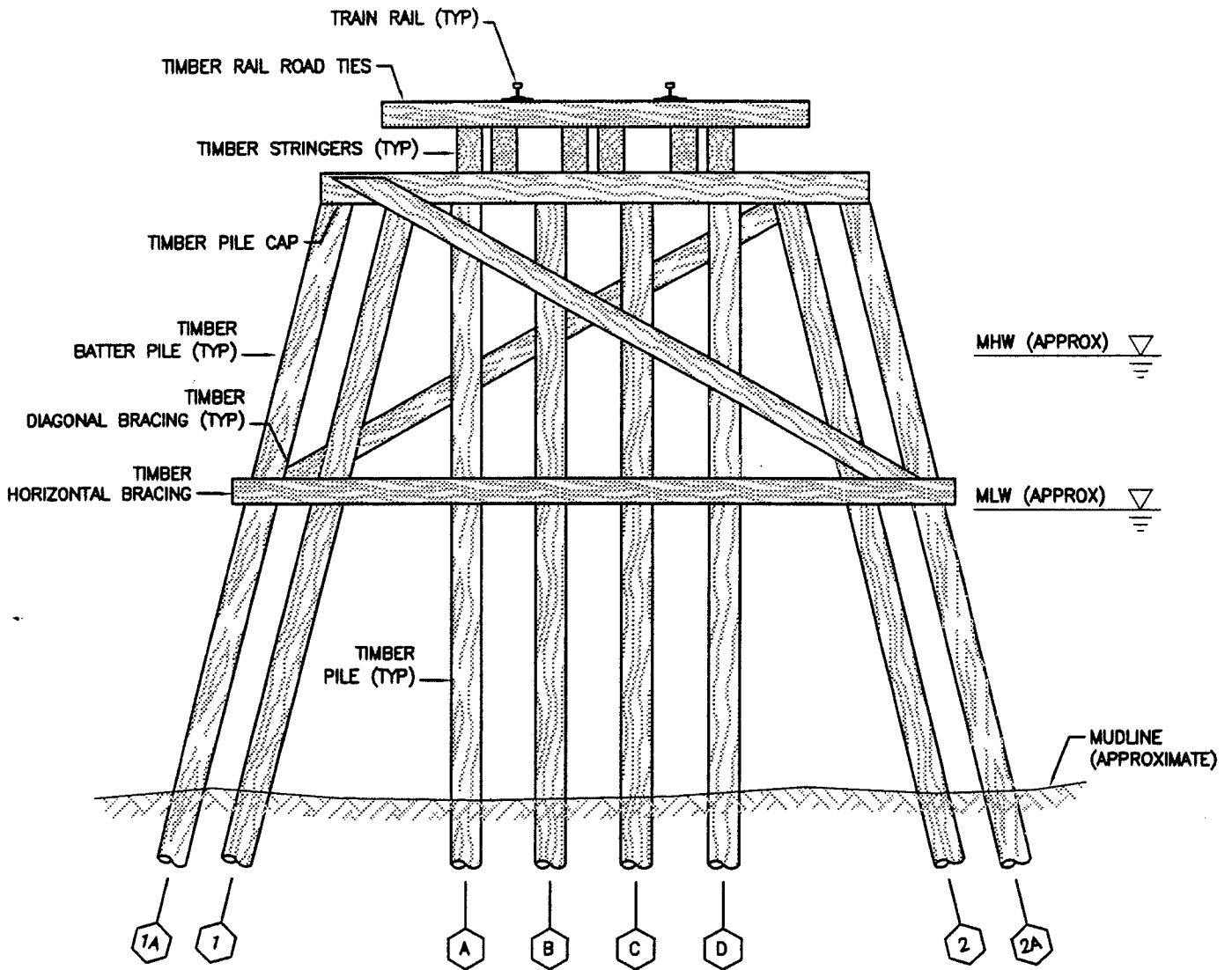

TYPICAL 8 PILE SECTION

SCALE: 3/16"=1'-0"



CHILDS ENGINEERING CORPORATION
 BOX 333 MEDFIELD, MASSACHUSETTS 02052 U.S.A.
 Phone: (508) 359-8945 Fax: (508) 359-2751
 E-mail: mail@childseng.com

Designed by:		Date:	
PDI		11/07/05	
Drawn by:	Chk'd by:	Design file no.	
APL	PDI	195505-03	
Reviewed by:		Plot Scale:	
CDS		1"=0'-1"	

BACK COVE RAILROAD BRIDGE INSPECTION
 HNTB CORPORATION
 PORTLAND, ME

TYPICAL 8 PILE BENT

Sheet
 reference
 number:

M-03
 Sheet 3 of 4

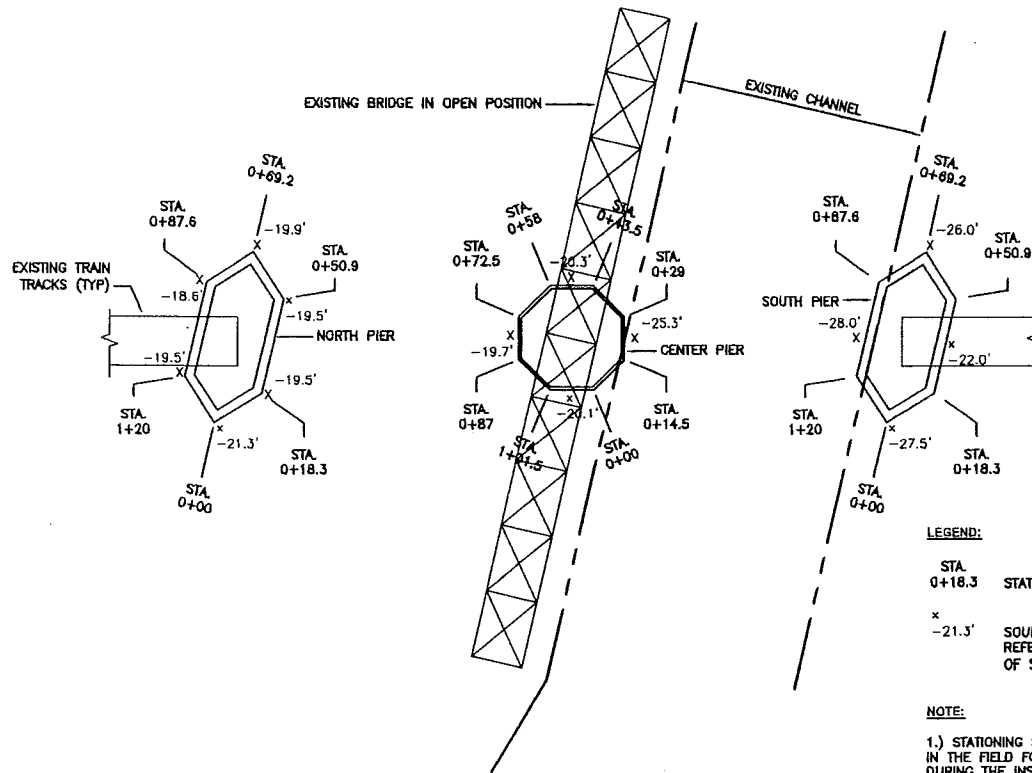

SWING BRIDGE PLAN

SCALE: 1"=40'-0"

LEGEND:

STA
0+18.3 STATIONING IN FEET

x
-21.3' SOUNDING IN FEET,
REFERENCE DATUM IS TOP
OF SHEET PILE EL. 0.0'

NOTE:

- 1.) STATIONING SHOWN WAS IMPLEMENTED IN THE FIELD FOR USE AS REFERENCE DURING THE INSPECTION.
- 2.) ALL STRUCTURES SHOWN ARE APPROXIMATE



CHILDS ENGINEERING CORPORATION
 BOX 333 MEOFIELD, MASSACHUSETTS 02032 U.S.A.
 Phone: (508) 359-8945 Fax: (508) 359-2751
 E-mail: mail@childseng.com

Mark	Description	Date	Appr.

Designed by:		Date:	
PDI		11/07/05	
Drawn by:	Check by:	Design file no.	
APL	PDI	195505-04	
Reviewed by:		Plot Scale:	
COS		1"=0'-1"	

BACK COVE BRIDGE INSPECTION
 HNTB CORPORATION
 PORTLAND, ME

BRIDGE PLAN

Sheet reference number:
M-04
 Sheet 4 of 4

