

Chapter 9 - Separator BMPs

A number of devices, structures and systems are available for providing varying levels of pretreatment of stormwater before it enters a BMP. These range from the relatively simple modified catch basin (catch basin with a sump and oil trap) to the sophisticated (and expensive) coalescing plate oil separator. The devices discussed in this Chapter include:

9.1 - WATER QUALITY INLET

The water quality inlet is a conventional stormwater drainage structure (catch basin) provided with a sump which will trap coarse sediment and non-floating debris, and a hood which prevents floating debris and floating hydrocarbons from exiting the catch basin. Existing catchbasins can be readily modified, in some instances, to retrofit an existing system to intercept coarse sediment and floating debris.

High flow events can result in turbulent flows within the basin and re-suspend accumulated sediments, so the contributing watershed should be kept small; but, size limits on commercially available hood castings will limit the allowable size of the outlet pipe and its drainage area. A standard catchbasin or water quality inlet is shown in Figure 10.1.

Sump: A water quality inlet should be provided with a four foot (minimum) sump to collect sediments. Larger sumps should be provided for areas that receive heavy sanding or where a heavy sediment load is anticipated.

Hood: Hood dimensions are generally determined by the pipe size, and are commercially available through a number of vendors. They typically use a cover, an elbow or tee with the inlet of the fitting pointed toward the floor of the basin. However, the hood must be vented to allow the basin to drain, and to prevent floating material from being suck through the fitting and exiting the basin. A threaded cap should also be placed in-line with the pipe for cleaning access.

Maintenance: Sediment removal from the sump and any floating debris and products is imperative for the continuity of the effectiveness of the structure. The sump needs cleaning when sediments are visible at the bottom of the outlet pipe.

- **Inspection:** Water quality inlets should be inspected three to four times annually.
- **Sediment Removal:** Sediment should be removed when accumulation is within 6 inches of the bottom of the hood.

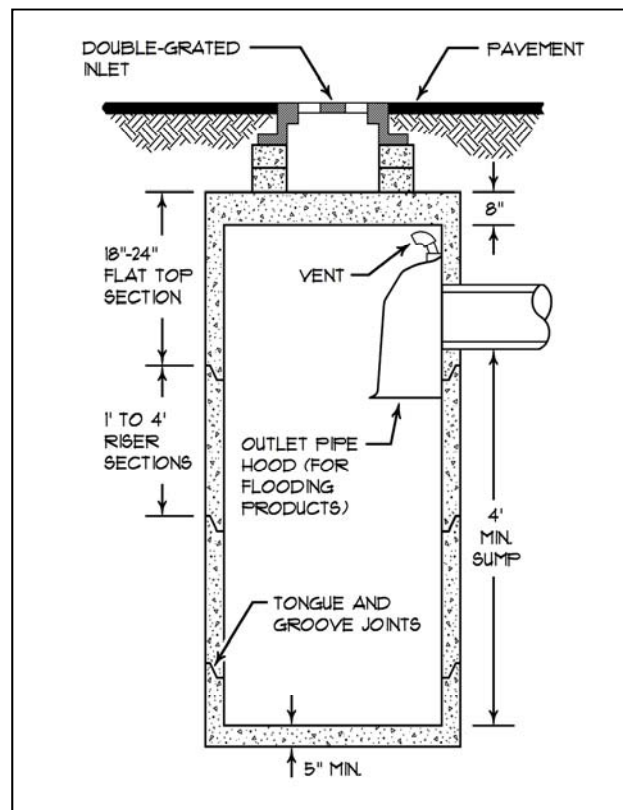

Figure 9.1 - Water Quality Inlet

9.2 - OIL/GRIT AND OIL/WATER SEPARATOR

Oil/grit separators remove sediment and hydrocarbons and are used for areas with heavy traffic or high potential for petroleum spills (fueling stations or commercial loading areas, etc. They should be close to the source of pollutants and before they can be conveyed to storm sewers or BMPs such as infiltration trenches. Soluble pollutants will most likely pass through oil/grit separators.

A typical oil/grit or oil/water separator has two chambers as shown in Figure 10.2. Runoff enters the first chamber, which contains a permanent pool of water and where coarse sediment is trapped by settling. The first chamber can also trap floating trash and debris, such as leaves. Then, runoff is drawn from the lower part of the pool with an inverted pipe elbow to trap floating oils and hydrocarbons to be discharge from to the second chamber which also contains a permanent pool of water for a second settling opportunity. Some hydrocarbons may become adsorbed to sediment particles which will settle out. There are several proprietary oil/grit and oil/water separator devices available for the treatment or pre-treatment of stormwater. For selection and design of proprietary oil/grit separator devices, refer to the product literature for these structures.

Pool Storage: For the structure to provide even moderate pollutant removal benefits, 400 cubic feet or more of permanent pool storage should be provided per acre of drainage area. Also, the pools should be at least 4 feet deep.

Maintenance: The performance of oil/grit separators is very dependent on the regular and frequent removal of trapped sediments and floating products, and should be cleaned out at least twice a year. Failure to clean them out can result in the re-suspension and loss of previously trapped material. The designer should consult the Maine DEP Bureau of Waste Management to determine proper disposal of the oil-contaminated water sediment and slurry prior to the installation of these devices at a site.

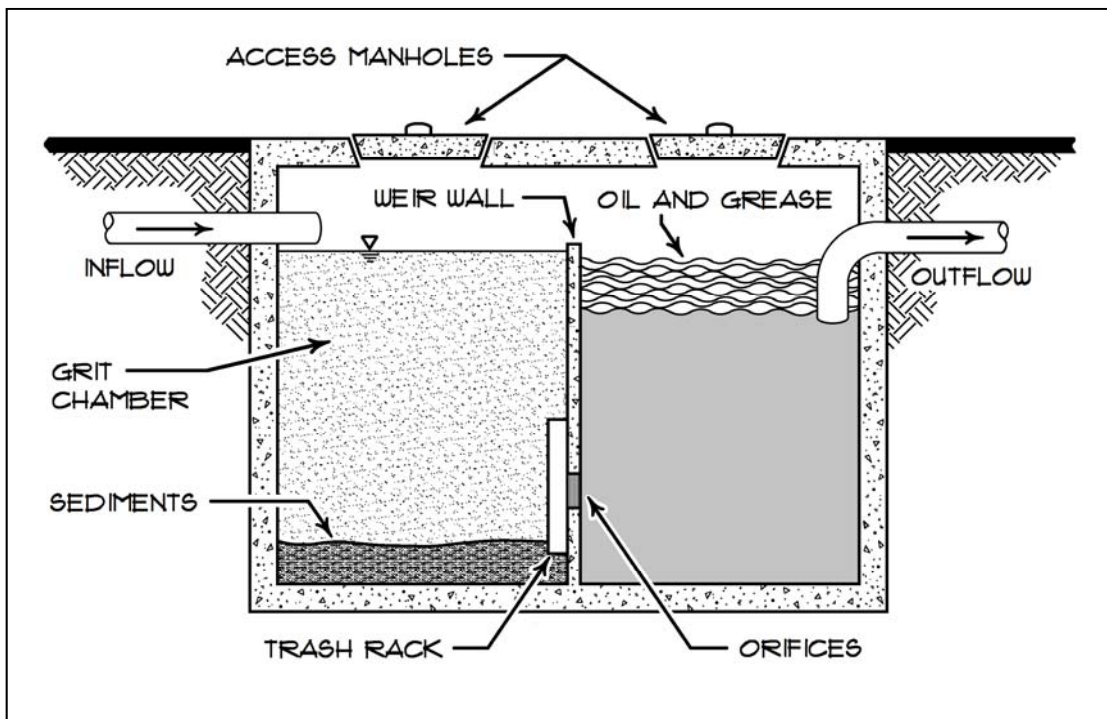

Figure 9.2 – Oil and Water Separator