

# ROXWIND

## RoxWind LLC's Application for Small-Scale Wind Energy Certification

---

March 20, 2018



Prepared By:

### **ROXWIND LLC**

Lindsay Deane-Mayer, Palmer Management Corporation  
13 Elm Street, Suite 200, Cohasset, MA 02025  
781-383-3200

0. Table of Contents

## Table of Contents

1. Project Description
  - 1.1. Summary
  - 1.2. Background
  - 1.3. Wind Energy Generators
  - 1.4. Access Roads and Crane Pads
  - 1.5. Interconnection
  - 1.6. Project Layout and Site Plans
  - 1.7. Site Control
  - 1-A Draft Construction Schedule
  - 1-B Project Layout, Topographic Site Plans, Supporting Documents
  - 1-C Site Control Documentation
  
2. Noise
  - 2.1. State Standards
  - 2.2. Local Standards
  - 2.3. Sound Modeling Approach
  - 2.4. Sound Modeling Results Summary
  - 2.5. Sound Modeling Compliance Testing
  - 2.6. Sound Complaint and Response Procedure
  - 2-A Sound Level Assessment Report
  
3. Shadow Flicker
  - 3.1. State Standards
  - 3.2. Local Standards
  - 3.3. Shadow Flicker Modeling Approach
  - 3.4. Shadow Flicker Modeling Results Summary
  - 3-A Shadow Flicker Assessment Report
  
4. Environmental Impacts
  - 4.1. State Standards
  - 4.2. Local Standards
  - 4.3. Overview
  - 4.4. Environmental Reports



## 0. Table of Contents

- 4.5. Additional Environmental Filings
  - 4.6. Incidental Take Permit Summary
  - 4-A MDIFW Letter RE: Information Request - Horseshoe Valley Wind, Roxbury, May 31, 2016
  - 4-B Roxbury Wind Development Natural Resource Inventory
  - 4-C Rare Species Survey Report
  - 4-D Northern Long-Eared Bat (*Myotis septentrionalis*) Acoustic Survey and Bicknell's Thrush (*Catharus bicknelli*) Survey
  - 4-E Soil Survey Report
  - 4-F Draft - RoxWind: Incidental Take Plan for the little brown bat (*Myotis lucifugus*) & eastern small-footed bat (*Myotis leibii*)
5. Scenic Resource Impact Assessment
- 5.1. State Standards
  - 5.2. Local Standards
  - 5.3. Scenic Resource Impact Assessment Approach
  - 5.4. Scenic Resource Impact Assessment Summary
  - 5-A Visual Impact Assessment
6. Setbacks and Public Safety
- 6.1. State Standards
  - 6.2. Local Standards
  - 6.3. Setback Summary
  - 6.4. Public Safety Summary
  - 6-A Letter RE: Proposed RoxWind Wind Energy Facility: Fire, Health and Safety Plan, February 22, 2018
  - 6-B General Description: Setback Considerations for Wind Turbine Siting (2017)
  - 6-C Letter RE: RoxWind Project - Setback from Property Line, March 5, 2018
  - 6-D RoxWind - 15.2 MW Wind Project: Initial Fire, Health and Safety Plan
7. Decommissioning
- 7.1. State Standards
  - 7.2. Local Standards
  - 7.3. Major Components' Useful Life
  - 7.4. Decommissioning Timeline
  - 7.5. Decommissioning Cost
  - 7.6. Decommissioning Financial Assurance
  - 7.7. Extension and Repowering Options
  - 7-A Decommissioning Cost Estimates from Baldwin Energy and Reed & Reed, Inc.
8. Public Notice and Meetings

RoxWind LLC  
Small Wind Certification Application

0. Table of Contents

- 8.1. State Standards
- 8.2. Public Informational Meeting
- 8.3. Notice of Intent to File
- 8.4. Application Submitted to Town
- 8.5. Public Notice Filing and Certification
- 8-A Notices Published in Sun Journal and Rumford Falls Times
- 8-B List of Property Owners to whom Notices were Sent via Certified Mail and Copy of Such Notices
- 8-C Town of Roxbury's Posting of Public Informational Meeting
- 8-D Public Informational Meeting Handouts
- 8-E Public Notice Filing and Certification Form

9. Miscellaneous

- 9.1 Application for Small-Scale Wind Energy Certification
- 9.2 Certificate of Good Standing
- 9.3 Federal Aviation Administration – Determination of No Hazard
- 9-A Application for Small-Scale Wind Energy Certification
- 9-B RoxWind's Certificate of Good Standing
- 9-C FAA Determinations of No Hazard

**Section 1**  
**Project Description**

## 1. Project Description

# Project Description

## 1.1 Summary

RoxWind LLC (the “Applicant” or “RoxWind”), managed by Palmer Management Corporation (together with its affiliates, “Palmer”)<sup>1</sup> and developed in partnership with Horseshoe Valley Wind LLC<sup>2</sup>, is proposing a 4-turbine wind energy facility in the Town of Roxbury (the “Town”) on North Twin Mountain (the “Project”). The Project includes: 4 wind energy generators, including their foundations, access roads and crane pads to transport the equipment up the mountain and assemble it on site, interconnecting equipment (as determined by the interconnection utility, Central Maine Power (“CMP”), and the Independent System Operator of New England (“ISO-NE”)), and related infrastructure and communication necessary to construct, operate, and maintain the facility. The Project is designed to conform to the State’s Small-Wind Certification process.

## 1.2 Background

The Project has been in development since 2012 when the landowner entered into a lease agreement for the permitting, construction and operation of a wind energy project. Since then, a temporary meteorological tower was erected on site to verify the wind resource and energy analyses have been undertaken. In addition, the project has completed environmental studies, consulted with State agencies, and received determinations of no hazard from the Federal Aviation Administration.

The Project has been presented to the Town at multiple Selectmen and Planning Board hearings starting in 2014.<sup>3</sup> The turbines are sited along the ridgeline of North Twin Mountain. North Twin Mountain is within the Town of Roxbury’s “Mountain District” – the Mountain District is identified in the Town’s Natural Land Use Ordinance as appropriate for wind energy development. The Applicant submitted a Building Permit application to the Town’s Planning Board on February 22, 2018, during a regularly scheduled and public meeting of the Planning Board. On March 7, 2018, the Applicant hosted a Public Informational Meeting in Roxbury to answer questions about the Project from the public. (See Section 8 for more details about the Public Informational Meeting.)

## 1.3 Wind Energy Generators

---

<sup>1</sup> For more on Palmer Management Corporation and its affiliates, please visit [www.palmcap.com](http://www.palmcap.com)

<sup>2</sup> Horseshoe Valley Wind LLC is a collaboration of Maine residents who are actively developing wind energy opportunities in their home state.

<sup>3</sup> Including on: 10/28/2014, 10/27/2015, 11/14/2017, 12/14/2017, 1/25/2018, 2/22/2018

## 1. Project Description

The Applicant proposes installing four GE-3.8-130 (or similar<sup>4</sup>) machines. The machines were selected due to their nameplate capacity (3.8 MW), allowing the Applicant to maximize the output of the site while minimizing the Project's footprint.

### 1.4 Access Roads and Crane Pads

The Project is designed to utilize an existing access road that originates from Horseshoe Valley Road and heads up the mountain to near the peak. The existing access road will be widened during construction for delivery of major components and adequate drainage has been designed to manage water flow and long-term maintenance. After the Project is fully commissioned, the Applicant will revegetate portions of the access road to provide stormwater treatment and decrease the overall footprint of the Project.

At the top of the ridgeline, there are cleared areas that have been created through the historical use of the property – likely attributable to logging and recreational use along the ridgeline. A new road will be constructed, partially using these cleared areas, extending from the first turbine to the fourth turbine. The road at the top of the ridgeline has been designed to avoid and minimize wetland impacts and new clearing while maintaining a feasible route among the turbines. The area around each turbine will be cleared and leveled to allow for the turbines to be erected. Similar to the access road, the extension of road along the ridgeline has been designed with appropriate drainage, and the Applicant will revegetate portions of the cleared area after commissioning, but in any event within one year of disturbance.<sup>5</sup>

### 1.5 Interconnection

The Project is in the ISO-NE queue and awaiting study. The outcome of the studies may impact the final interconnection point and will dictate the equipment required by CMP and ISO-NE to interconnect and operate the facility.

Among the wind turbines, the Applicant proposes to install underground communication and electrical infrastructure. This will be placed within the boundaries of the improved road. Near the existing CMP easement (between turbines 1 and 2), the lines will ascend a riser pole and be overhead.

After the riser pole, there are two proposed routes to complete the interconnection. Both are being discussed with CMP and the final selection will be determined through consultation with CMP. .

Option 1) After the riser pole, install the necessary protection and control equipment, as dictated by CMP and ISO-NE, to tap into a CMP owned line at the top of the mountain that would run to the Project through the existing CMP easement.

Option 2) After the riser pole, follow the existing transmission line down toward the end of the leased property while staying on the leased parcel until reconnecting with a CMP easement at the bottom of

---

<sup>4</sup> The GE turbines have a 150 meter tip height. By using the term "or similar," the Applicant is referring to similarly configured wind turbines with, at a maximum, 150 meter tip heights.

<sup>5</sup> See Exhibit 1-A, Draft Construction Schedule.

## 1. Project Description

the mountain. At that point, the Applicant would install the necessary protection and control equipment, as dictated by CMP and ISO-NE, to tap into a CMP owned line at the bottom of the mountain.

Option 1 increases the Project's footprint by approximately zero acres. Option 2 increases the Project's footprint by approximately one and a half (1.5) acres. Both options keep the project below 20 acres.

### 1.6 Project Layout and Site Plans

An aerial view of the Project is inserted below.



The Project as designed will occupy 16.9 acres plus the interconnection route for a total of between 16.9-18.4 acres. The total new impervious area will be less than three acres. Site Plans assuming Option 1 and supporting documents are included as Exhibit 1-A.

### 1.7 Site Control

The Applicant has an executed lease agreement. The lease extends until the 25<sup>th</sup> anniversary of the Project's commercial operation date with an option to extend for an additional 20-year period. A memorandum of lease was recorded in the Oxford East County Registry of Deeds on April 27, 2015 (Book 5219, Page 54) and a memorandum of the assignment of said lease to Applicant was recorded on January 24, 2018 (Book 5390, Page 86). Recorded copies of the memorandum of lease and memorandum of assignment of lease are included in Exhibit 1-B.



**1-A**

**Draft Construction Schedule**

## ROXWIND Construction Schedule - March 20, 2018 (DRAFT)

Activity	Dur (mos)	Start Month	End Month	1	2	3	4	5	6	7	8	9	10	11	12	13	14	15	16	17	18
<b>Construction</b>																					
Construction Bids & Contracts	6	0	6	X	X	X	X	X	X												
Mobilization	1	7	7							X											
Site & Road Work*	3	8	11								C	C	C	C							
UG Electrical	1	10	11									X	X								
Foundations*	1	11	12										C	C							
Turbine Delivery & Erection*	1	12	13											C	C						
Mechanical Completion*	1	13	14												C	C					
Site Restoration	1	13	14												X	X					
Testing & Commissioning*	1	14	15														C	C			
COD	0	15	15																X		

\*Indicates Critical Path Activities

**1-B**

**Project Layout, Topographic Site Plans,  
Supporting Documents**



**CLIENT**

**ROXWIND LLC**  
 13 ELM STREET, SUITE 200  
 COHASSET, MASSACHUSETTS 02025  
 ATTN: LINDSAY DEANE-MAYER

# ROXBURY WIND PROJECT

## ROXBURY TOWNSHIP, MAINE

### PERMIT DOCUMENTS - MARCH 2018



Stantec Consulting Services Inc.  
 30 Park Drive  
 Topsham ME 04086 U.S.A.  
 Tel. 207.729.1199  
 Fax. 207.729.2715  
 www.stantec.com

**PREPARED BY**

**STANTEC**  
 482 PAYNE ROAD  
 SCARBOROUGH COURT  
 SCARBOROUGH, MAINE 04074  
 207.883.3355  
 ATTN: STEVE BUSHEY  
 KRISTA REINHART

**DATA SOURCE**

**TOPOGRAPHIC INFORMATION:**

**AERIAL SURVEY AND PHOTO, INC.**  
 546 AIRPORT ROAD  
 P.O. BOX 659  
 NORRIDGEWOCK, MAINE 04957  
 207.634.2006

HORIZONTAL DATUM: 1983 NAD (1996adj.) UTM ZONE 19 US FEET

VERTICAL DATUM: 1988 NAVD US FEET

**BOUNDARY INFORMATION:**

TBD

**TOWER LOCATIONS:**

BY OWNER

**WETLANDS / NATURAL RESOURCES:**

**KLEINSCHMIDT**  
 141 MAIN STREET  
 P.O. BOX 650  
 PITTSFIELD, ME 04967  
 207.487.3328

**ELECTRICAL DESIGN:**

TBD

**SOIL SURVEY:**

**STANTEC**  
 482 PAYNE ROAD  
 SCARBOROUGH COURT  
 SCARBOROUGH, MAINE 04074  
 207.883.3355  
 ATTN: RODNEY KELSHAW

**INDEX**

- C-1.0 CIVIL COVER SHEET FOR ACCESS AND CRANE ROADS
- C-2.0 GENERAL NOTES AND LEGEND
- C-3.0 OVERALL ORIENTATION MAP
- C-4.0 ROADWAY AND PAD SECTION DETAILS
- C-5.0 BACK SLOPE DETAILS
- C-6.0 DITCH AND CULVERT DETAILS
- C-7.0 SOIL HYDROLOGY PRESERVATION DETAILS
- C-8.0 EROSION CONTROL DETAILS
- C-8.1 EROSION CONTROL NOTES
- C-8.2 EROSION CONTROL NOTES
- C-9.0 MISCELLANEOUS DETAILS
- C-N1.0 ACCESS ROAD PLAN AND PROFILE (STA 100+00 TO 128+00)
- C-N1.1 ACCESS ROAD PLAN AND PROFILE (STA 128+00 TO 156+00)
- C-N1.2 CRANE ROAD PLAN AND PROFILE (STA 156+00 TO 184+00)
- C-N1.3 CRANE ROAD PLAN AND PROFILE (STA 184+00 TO 189+98)
- C-N1.4 CRANE ROAD PLAN AND PROFILE (STA 200+00 TO 204+77)

Copyright Reserved

The Contractor shall verify and be responsible for all dimensions. DO NOT scale the drawing - any errors or omissions shall be reported to Stantec without delay. The Copyrights to all designs and drawings are the property of Stantec. Reproduction or use for any purpose other than that authorized by Stantec is forbidden.

Consultants

Legend

Notes

**DRAFT**

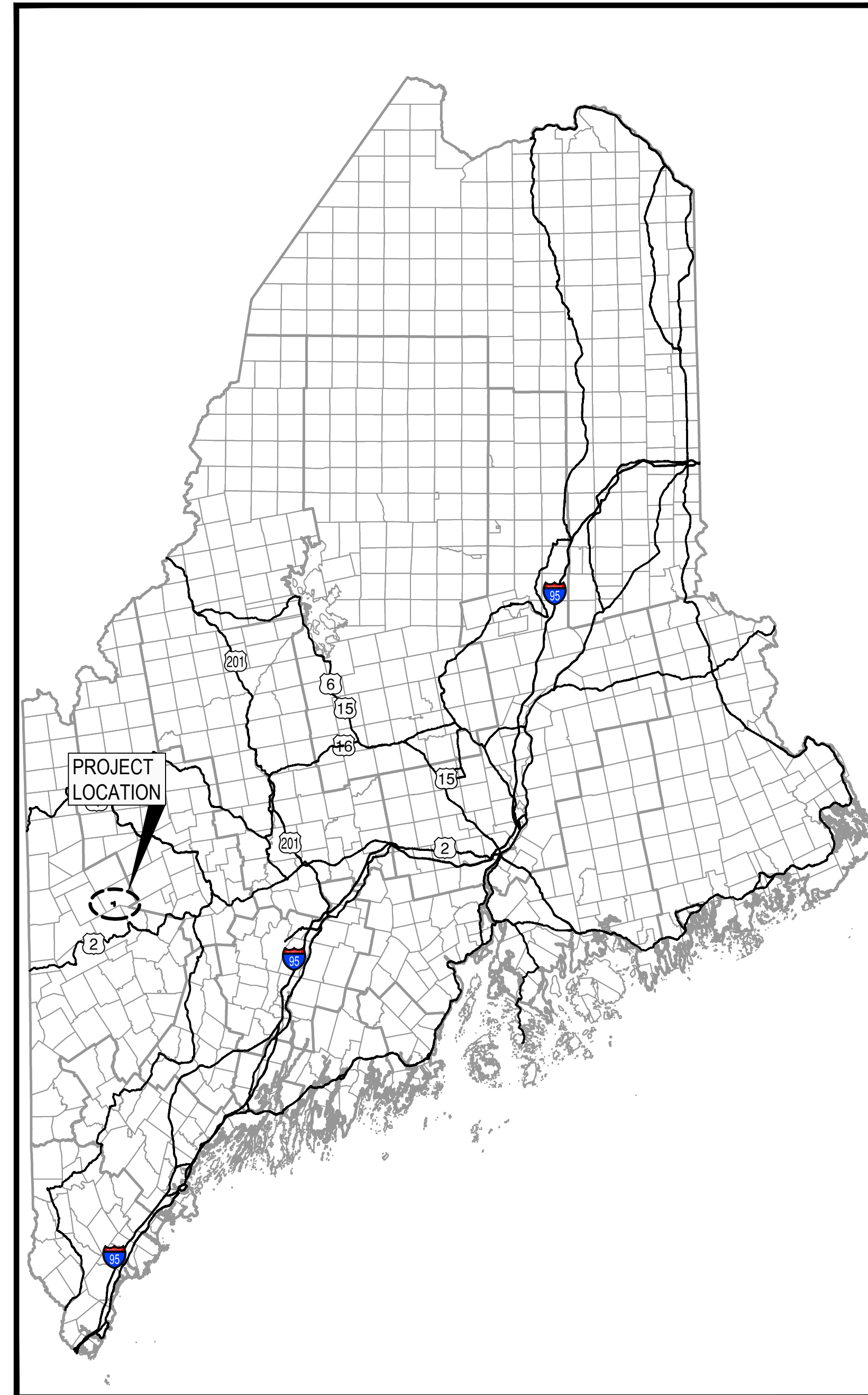

**LOCATION MAP**  
 SCALE: 1" = 24 MILES

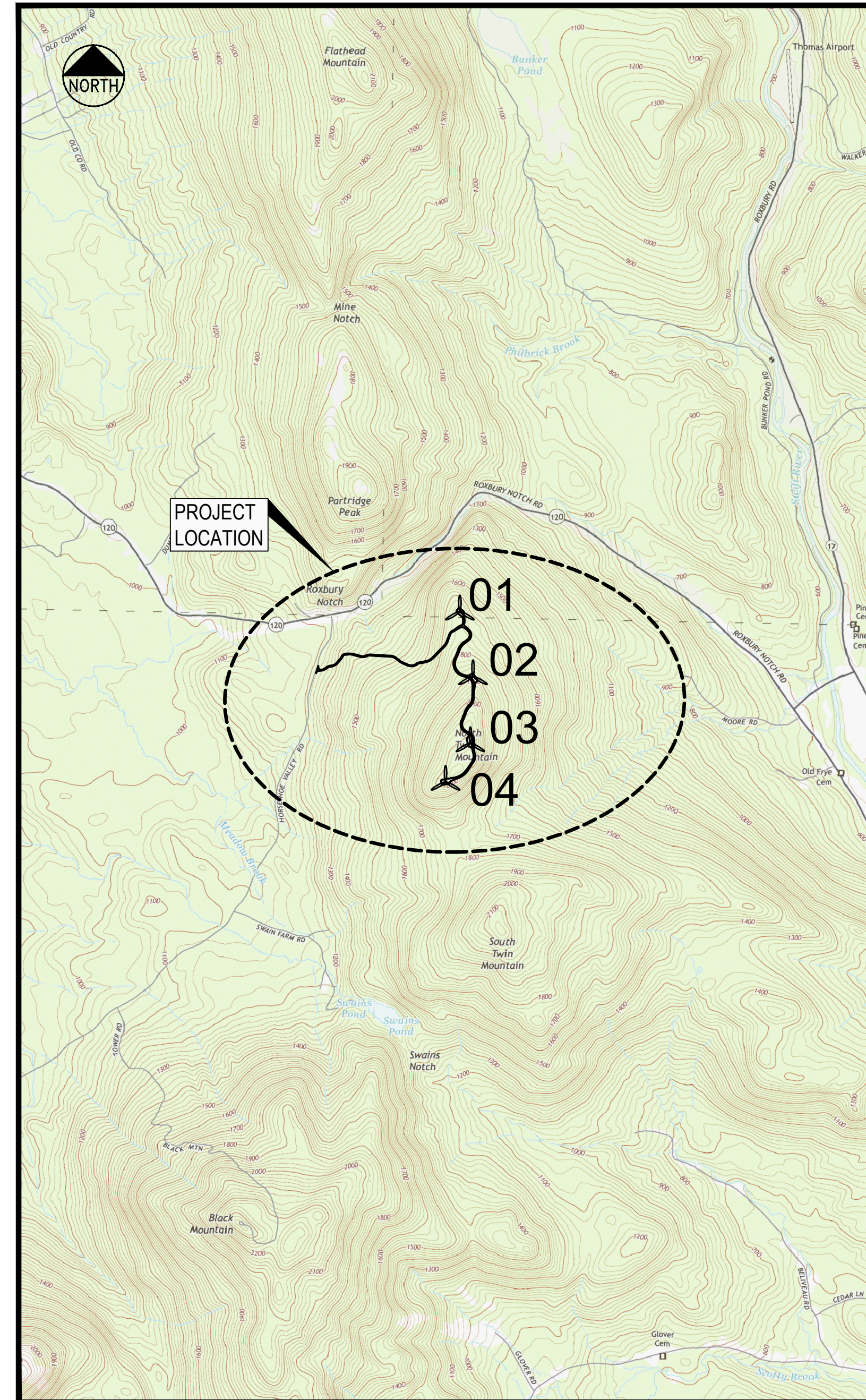

**VICINITY MAP**  
 SCALE: 1" = 2500'

**NOTE:**  
 THESE PLANS REPRESENT ONLY THE TURBINE ACCESS AND CRANE PATH ROADS FOR GENERAL DELIVERY AND ERECTION OF THE WTG. SEE ADDITIONAL PLANS BY (TBD) FOR THE TRANSMISSION SYSTEM.

Revision	By	Appd.	YY.MM.DD
PERMIT DRAWINGS SUBMITTED FOR PROJECT TEAM REVIEW	EPL	SRB	18.03.09

Issued	By	Appd.	YY.MM.DD

File Name:	KAB	SRB	SRB	18.03.04
P.E. STEPHEN R. BUSHEY	Dwn.	Chkd.	Dsgn.	YY.MM.DD

Permit-Seal

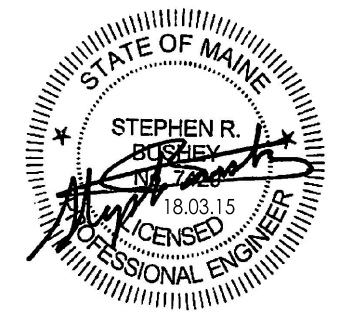

Client/Project  
 ROXWIND LLC  
 ROXBURY WIND PROJECT  
 ROXBURY TOWNSHIP, MAINE

Title  
**CIVIL COVER SHEET FOR ACCESS AND CRANE ROADS**

Project No.	Scale	
195601220	AS NOTED	
Drawing No.	Sheet	Revision

C-1.0



# GENERAL NOTES

## GENERAL NOTES

- VACANT.
- PLANIMETRIC AND TOPOGRAPHIC INFORMATION ARE SHOWN IN UTM ZONE 19, US-FEET, NAD 83. VERTICAL DATUM IS NAVD 1988 US-FEET. PROJECT BENCHMARKS TO BE PROVIDED AT TIME OF CONSTRUCTION.
- SOIL SURVEY INFORMATION PROVIDED BY STANTEC.
- NATURAL RESOURCE DATA, INCLUDING WETLAND DELINEATION BOUNDARIES AND OTHER SENSITIVE RESOURCES, PROVIDED BY KLEINSCHMIDT.
- COLLECTOR AND TRANSMISSION SYSTEM LAYOUT PROVIDED BY (TBD).
- EROSION CONTROL MEASURES TO BE INSTALLED AND MAINTAINED IN ACCORDANCE WITH "MAINE EROSION AND SEDIMENTATION CONTROL: BEST MANAGEMENT PRACTICE", BY MEDEP, LATEST VERSION.

## CLEARING AND STOCKPILING OPERATIONS

- INSTALL EROSION CONTROL MEASURES PRIOR TO SOIL DISTURBANCE.
- ACCESS ROAD AND CRANE ROAD, EQUIPMENT LAYDOWN AREA/TURBINE AREAS: CLEAR TIMBER AND BRUSH WITHIN LIMIT OF DISTURBANCE. STUMPS TO BE REMOVED IN AREAS WHERE STRUCTURES (ie ACCESS ROAD, CRANE ROAD AND TURBINE AREAS) ARE PROPOSED. STUMPS SHALL BE GROUND TO GRADE OR REMOVED AND GROUND ON-SITE TO GENERATE EROSION CONTROL MIX (ECM).
- WHILE THE ENTIRE ROAD SYSTEM MAY BE CLEARED IN ONE EFFORT, THE ROADS WILL BE CONSTRUCTED IN SEGMENTS WHERE EACH SEGMENT IS GRUBBED, CONSTRUCTED AND PROTECTED PRIOR TO EARTHWORK ON THE NEXT SEGMENT AS APPROVED BY ENGINEER. THIS CONSTRUCTION SEQUENCE IS INTENDED TO PREVENT LARGE AREAS FROM BEING EXPOSED, WITHOUT TEMPORARY STABILIZATION, TO EROSION DURING MAJOR RAIN EVENTS. A SEGMENT IS DEFINED AS AN AREA CLEARED AND GRUBBED, MULTIPLE SEGMENTS IN DIFFERENT AREAS OF THE PROJECT MAY BE CONSTRUCTED CONCURRENTLY.
- MINIMIZE THE AMOUNT OF DISTURBANCE AT ANY ONE TIME BY STAGING CONSTRUCTION AS MUCH AS PRACTICAL FOR EFFICIENT CONSTRUCTION OF THE PROJECT. WHERE FEASIBLE, CONTRACTOR OPERATIONS SHALL MAINTAIN THE NATURAL COVER MATERIAL OR USE NATURAL VEGETATIVE BUFFER STRIPS TO AID IN SEDIMENT RETENTION AND TO REDUCE THE POTENTIAL OF SOIL EROSION.
- STRIPPED TOPSOIL SHALL BE STOCKPILED ON-SITE WITHIN DISTURBED AREAS FOR USE IN STABILIZING ACCESS ROAD DITCHES AND FOR FINAL STABILIZATION OF ROAD SHOULDERS, TURBINE AREAS, LAYDOWN AREAS AND SLOPES. AN EROSION CONTROL BARRIER SHALL BE INSTALLED AROUND SOIL STOCKPILES THAT ARE EXPECTED TO REMAIN UNDISTURBED FOR MORE THAN 48 HOURS OR PRIOR TO A STORM EVENT. THE BARRIERS SHALL BE ADEQUATELY LOCATED AND REINFORCED TO PREVENT COLLAPSE DURING A STORM EVENT AND THE POTENTIAL SLUMPING OF THE PILE. IF NO ACTIVITY IS SCHEDULED WITHIN 30 DAYS, APPLY HAY AND/OR STRAW MULCH AS SPECIFIED HEREIN, UNLESS DIRECTED OTHERWISE. 4 INCHES OF ECM MAY ALSO BE USED. HAY/STRAW MULCH MAY ALSO BE SUPPLEMENTED BY TEMPORARY SEEDING WITH ANNUAL RYEGRASS AS SPECIFIED HEREIN FOR AREAS WHERE ADDITIONAL ACTIVITY IS NOT EXPECTED FOR SEVERAL MORE WEEKS. APPLY ANCHORED MULCH OR SUPPLEMENTAL SEEDING DURING WINTER CONSTRUCTION.
- STOCKPILE GENERATED ECM ON-SITE WITHIN DISTURBED AREAS.
- REMOVE EXCESS SOILS FROM SITE THAT WILL NOT BE USED FOR THE FINAL DESIGN AND STABILIZATION.

## CONSTRUCTION OF ACCESS ROAD AND CRANE ROAD

- PRIOR TO CONSTRUCTION, THE CONTRACTOR SHALL USE SURVEY CREWS TO ACCURATELY LOCATE ALL IMPROVEMENTS INCLUDING ROADWAY CENTERLINES AND LIMITS OF DISTURBANCE. PROVIDE ADDITIONAL STAKING AND MARKING AT LOCATIONS WHERE STORMWATER CONTROL MEASURES ARE TO BE INSTALLED.
- DUE TO DIFFERING SITE CONDITIONS, HORIZONTAL AND VERTICAL ADJUSTMENTS WITHIN PERMIT CONSTRAINTS MAY BE NECESSARY FOR PROPER CONSTRUCTION AND INTERPRETATION OF THE CONTRACT DRAWINGS. FIELD MODIFICATIONS WILL NOT CREATE ANY ADDITIONAL CLEARING/FILLING NATURAL RESOURCE IMPACTS AND WILL NOT IMPACT THE INTENT OF THE STORMWATER DESIGN. ALL CHANGES SHALL BE REFLECTED IN THE PROJECT RECORD DRAWINGS.

## CONSTRUCTION OF PERMANENT STORMWATER MANAGEMENT SYSTEMS

- GRADING TO BE CONDUCTED IN ACCORDANCE WITH PERMITTED PERMANENT STORMWATER MANAGEMENT DESIGN.
- ONCE FINAL GRADES ARE ACHIEVED, EXPOSED SOIL SURROUNDING THE STORMWATER MANAGEMENT STRUCTURES SHALL BE PERMANENTLY STABILIZED AS DESCRIBED HEREIN.

## TURBINE PAD CONSTRUCTION

- FOLLOWING CONSTRUCTION OF THE WTG ASSEMBLY AREA SUBGRADES, BRING ASSEMBLY AREAS AND TURBINE PADS TO FINISH GRADE WITH CRUSHED AGGREGATE. SPREAD AND COMPACT MATERIAL AS NECESSARY TO THE LIMITS DEPICTED ON CONTRACT DOCUMENTS. VERTICAL ADJUSTMENTS WITHIN PERMIT CONSTRAINTS MAY BE NECESSARY TO ACCOMMODATE SPECIFIC SITE CONDITIONS. ALL ADJUSTMENTS SHALL BE APPROVED BY THE ENGINEER PRIOR TO IMPLEMENTATION.
- PORTIONS OF THE WTG ASSEMBLY AREA SURROUNDING THE TURBINE GENERATOR AND THE TURBINE PAD SHALL REMAIN AS A PERMANENT DISTURBANCE. ALL OTHER AREAS WITHIN THE WTG ASSEMBLY AREA SHALL BE PERMANENTLY STABILIZED AS DESCRIBED HEREIN.

## CLEAN-UP AND FINAL STABILIZATION

- AT STREAM CROSSINGS, COMPLETE FINAL RESTORATION (FINISH GRADE, SEED AND MULCH) OF ALL AREAS WITHIN 250 FEET OF THE WATERBODY WITHIN 48 HOURS OF FINAL GRADING UNLESS DIRECTED OTHERWISE. ALL OTHER AREAS OF EXPOSED SOIL SHALL BE PERMANENTLY RE-VEGETATED OR OTHERWISE PERMANENTLY STABILIZED WITHIN 7 DAYS OF FINAL GRADING.
- UPON COMPLETION OF CONSTRUCTION ACTIVITIES, ALL WORK AREAS SHALL BE CLEARED OF CONSTRUCTION DEBRIS AND OTHER MATERIALS.
- SPECIFIC CLEAN-UP REQUIREMENTS TO INVOLVE REMOVAL OF ALL TEMPORARY WORK TRAILERS IF ANY, REMOVAL OF MATERIAL AND EQUIPMENT, DISPOSAL OF ALL RUBBISH RESULTING FROM CLEARING CONSTRUCTION, ROUGH GRADING AND STABILIZATION OF EMBANKMENTS MADE FOR CONSTRUCTION PURPOSES, FILLING OF ANY EXCAVATION AND REPAIRING RUTS IN ACCESS ROAD AND CRANE ROAD.

## WINTER CONSTRUCTION NOTES

FOR WORK PROPOSED DURING THE WINTER SEASON (TYPICALLY NOVEMBER 1 - APRIL 15), THE CONTRACTOR SHALL ADHERE TO THE FOLLOWING PRACTICES:

- A PLAN AND SCHEDULE OF ACTIVITIES SHALL BE SUBMITTED TO THE OWNER FOR APPROVAL PRIOR TO ANY WORK BEING DONE.
- LIMIT THE TOTAL AREA OF EXPOSED SOIL TO THAT IN WHICH EARTH WORK CAN BE COMPLETED WITHIN 15 DAYS AND MULCHED WITHIN ONE DAY PRIOR TO A PRECIPITATION EVENT.
- EXPOSED SOIL MAY BE LEFT BARE FOR NO MORE THAN 15 DAYS.
- MULCH ALL EXPOSED SOIL WHERE NO ACTIVITY IS SCHEDULED WITHIN 7 DAYS AND PRIOR TO A FORECASTED SNOW EVENT OF MORE THAN 1 INCH.
- WHERE PRACTICABLE, MULCH SHOULD BE APPLIED AT THE END OF EACH DAY'S WORK FOR AREAS THAT ARE FINAL GRADED. OTHERWISE, MULCH THE FOLLOWING DAY.
- DO NOT APPLY MULCH OVER MORE THAN 1 INCH OF SNOW.
- HAY OR STRAW MULCH SHALL BE APPLIED AT 140 LBS/1000 SF (APPROX. 4 BALES) AND SO THAT THE GROUND SURFACE IS NOT VISIBLE THROUGH THE MULCH.
- ECM IS THE PREFERRED MULCHING MATERIAL AND SHALL BE APPLIED AT A MINIMUM 4 INCH THICKNESS WITH HIGHER AMOUNTS AS DESCRIBED HEREIN.

- IF ECM IS NOT AVAILABLE, INSTALLATION OF SILT FENCE ON FROZEN GROUND MAY BE MODIFIED FROM ILLUSTRATIONS AND DETAIL DRAWINGS TO SUBSTITUTE SIX INCHES OF SUITABLE NON-ORGANIC MATERIAL OVER THE BOTTOM OF THE SILT FENCE IN LIEU OF TRENCHING AND BACKFILLING FABRIC.
- A DOUBLE ROW OF EROSION CONTROL BARRIER WILL BE USED WHERE REQUIRED WITHIN 100 FEET OF WETLANDS AND WATER BODIES.
- INSPECTION OF EROSION CONTROL MEASURES AND ANY NEEDED REPAIR/REPLACEMENT OF WHICH SHALL OCCUR EACH DAY.
- PERMANENT SEEDING IS NOT REQUIRED DURING THE WINTER SEASON. HOWEVER, IF DONE, THE CONTRACTOR SHALL FOLLOW PROCEDURES FOR DORMANT SEEDING. THE PERMANENT SEED MIX SHALL BE APPLIED AT THREE TIMES THE STANDARD RATE AND MULCHED. RE-VEGETATION SUCCESS MUST BE INSPECTED BY THE CONTRACTOR IN THE FOLLOWING SPRING (AFTER APRIL 15) AND RE-SEEDED AS NECESSARY IF VEGETATIVE COVER IS LESS THAN 75 PERCENT. ACCEPTANCE OF DORMANT SEEDING AS SUCCESSFUL WILL NOT OCCUR UNTIL AFTER JUNE 1 OF THE FOLLOWING YEAR.

## GRAVEL SURFACE SPECIFICATION

- THE TYPICAL GRAVEL SURFACE MATERIAL TO BE USED ON THIS PROJECT SHALL CONSIST OF 12" - 24" OF PROCESSED BLAST ROCK SIMILAR TO AN MDOT TYPE D OR AS APPROVED BY ENGINEER.

## SOIL HYDROLOGY NOTE

- TO THE EXTENT POSSIBLE, EXISTING DRAINAGE FEATURES HAVE BEEN IDENTIFIED AND ARE SHOWN ON THESE DRAWINGS.
- WHERE DRAINAGE FEATURES ARE IDENTIFIED DURING CONSTRUCTION THAT WERE NOT LOCATED ON THE PLANS, THE PROJECT'S FIELD ENGINEER AND CIVIL SUPERINTENDENT MAY BE REQUIRED TO REVIEW THESE AREAS WITH THE PROJECT'S WETLAND/SOIL SCIENTIST EXPERT AND/OR DESIGN ENGINEER TO DETERMINE THE APPROPRIATE PROJECT DETAIL TO BE EMPLOYED AT SUCH AREAS.

## PROJECT IMPLEMENTATION

- SUBSEQUENT TO CLEARING, THE ALIGNMENT OF PROJECT LAYOUT WILL BE STAKED OUT AT 50-FOOT CENTERS AND WALKED BY THE OWNER, THE GEOTECHNICAL ENGINEER, AND THE CONTRACTOR TO AGREE ON THE FOLLOWING:  
CONFIRMATION OR RECOMMENDED ADJUSTMENT OF HORIZONTAL AND VERTICAL ALIGNMENT;  
SELECTION OF CROSS SECTION TO BE USED IN THE AREA;  
LOCATIONS FOR CROSS CULVERTS; AND  
OTHER TOOLS TO BE EMPLOYED.
- IT WILL BE NECESSARY FOR THIS EFFORT TO PRECEDE CONSTRUCTION BY A SUFFICIENT PERIOD OF TIME IN ORDER THAT ADJUSTMENTS CAN BE MADE AND THE CONTRACTOR CAN HAVE FINAL CLEARING, BLASTING, AND PROPER MATERIALS ON HAND.

## REVEGETATION NOTES

- UPON COMPLETION OF ROADSIDE CUT AND FILL GRADING WHERE ECM MATERIAL HAS BEEN PLACED AS THE FINAL SURFACE TREATMENT, SEED MIX IS TO BE SPARSELY BROADCAST SPREAD OVER THE ECM. SEED IS TO BE DISPERSED IN LATE SUMMER/EARLY FALL WHEN GROUND CONDITIONS ARE SUFFICIENTLY MOIST, FOLLOWED BY A SECOND, LIGHTER APPLICATION IN LATE FALL. AN INSPECTION OF SEEDED AREAS IS TO BE CONDUCTED IN THE FOLLOWING LATE SUMMER TO ENSURE ADEQUATE SEEDING ESTABLISHMENT.
- AT THE END OF THE PROJECT ONCE THE WIDE TRAVEL SURFACES ARE NO LONGER NEEDED THE SAME SEEDING REQUIREMENTS NOTED ABOVE ARE TO BE APPLIED TO ALL ACCESS AND CRANE ROADS. REFER TO DETAILS FOR CRANE ROAD REVEGETATION LIMITS. EXCEPT FOR A 12' GRAVEL ACCESS WAY, 75'X35' CRANE PAD, 25' DIAM. FOUNDATION, AND 16' GRAVEL RING TO REMAIN ACROSS TURBINE PADS, THE PADS ARE TO BE SCARIFIED COVERED WITH 4-INCHES OF ECM AND SEEDED WITH SEED MIX AS NOTED ABOVE.
- IN THE EVENT VEGETATION DOES NOT BECOME ESTABLISHED IN ANY OF THE ABOVE NOTED AREAS ADDITIONAL ECM IS TO BE ADDED AND ADDITIONAL SEED MIX BROADCAST EACH LATE SUMMER/EARLY FALL UNTIL VEGETATION BECOMES ESTABLISHED. THOSE AREAS IN WHICH VEGETATION DOES NOT BECOME ESTABLISHED WITHIN THREE YEARS WILL BE INDIVIDUALLY ASSESSED TO DETERMINE IF SOIL MOISTURE, SEED, AND GROWING CONDITIONS (E.G., DEPTH OF ORGANIC MATERIAL, SUN EXPOSURE) ARE SUITABLE. BASED ON THAT REVIEW, REASONABLE MODIFICATIONS, INCLUDING DIRECT TRANSPLANTING OF SEEDLINGS IF NECESSARY, WILL BE UNDERTAKEN TO CORRECT DEFICIENCIES.

Side Slope Treatment Option	Recommended Maintenance Procedure
Loam and Seed with Mulch and Mesh	- Mowing. - Replacement of washout areas.
Erosion Control Mix with Mesh	- Replacement of lost Erosion Control Mix.
Stone Face	- Washing to remove sediment. - Replacing displaced stone. - Filling gaps with new stone.
Reinforced Turf or Reinforced Erosion Control Mix	- Mowing. - Replacement of damaged/removed reinforcement.
Rip Rap	- Removal of sediment. - Replacing displaced stones. - Filling gaps with new stone.
Alternate Fill with Reinforcement	- Mowing. - Repairation of damaged mesh.
Reinforced Embankment	- Removal of larger vegetation.
Rock Face	- Remove loose rock from rock face. - Stabilize deteriorated areas.

Turbine ID	NORTHING	EASTING	Pedestal Elevation (ft.)
1	N 44° 37' 30.72"	E 70° 37' 3.72"	1,758
2	N 44° 37' 15.24"	E 70° 36' 59.04"	1,902
3	N 44° 37' 0.12"	E 70° 36' 59.4"	2,114
4	N 44° 36' 49.32"	E 70° 37' 7.68"	2,120

# LEGEND

	EXISTING
	PARCEL BOUNDARY
	2 FOOT CONTOUR
	10 FOOT CONTOUR
	SPOT GRADE
	CULVERT
	PAVED SURFACE
	GRAVEL SURFACE
	TREE LINE
	TEST PIT / BORING
	ROCK OUTCROP
	BORROW AREA
	HIGH INTENSITY SOIL LINE
	SCS LINE
	CEMETERY
	DELINEATED WETLAND
	NORTHERN SPRING SALAMANDER 250' STREAM BUFFER
	SIGNIFICANT VERNAL POOL
	SIGNIFICANT VERNAL POOL BUFFER
	STREAM
	NATURAL RESOURCES DELINEATION LIMIT
<b>PROPOSED</b>	
	BUILDING
	ROAD ALIGNMENTS
	LAYDOWN AREA
	TURBINE LOCATION
	MET TOWER
	PERMANENT
	TEMPORARY
	CRANE PAD
	LIMIT OF CLEARING
	RESTRICTED CLEARING BUFFER AREA
	LAND MANAGEMENT ROAD ACCESS POINT
	ROADSIDE BUFFER
	DITCH TURNOUT BUFFER
	LEVEL LIP SPREADER BUFFER
	CULVERT
	AREA OF EXISTING PREDEVELOPMENT LAND
	MANAGEMENT ROAD REVEGETATED
	CHAIN LINK FENCE
	2 FOOT CONTOUR
	10 FOOT CONTOUR
	UTILITY POLE
	COLLECTION / TRANSMISSION SYSTEM - OVERHEAD LINE
	COLLECTION SYSTEM - UNDERGROUND LINE
	JUNCTION BOX



Stantec Consulting Services Inc.  
30 Park Drive  
Topsham ME 04086 U.S.A.  
Tel. 207.729.1199  
Fax. 207.729.2715  
www.stantec.com

## Copyright Reserved

The Contractor shall verify and be responsible for all dimensions. DO NOT scale the drawing - any errors or omissions shall be reported to Stantec without delay.  
The Copyrights to all designs and drawings are the property of Stantec. Reproduction or use for any purpose other than that authorized by Stantec is forbidden.

## Consultants

## Legend

## Notes

# DRAFT

PERMIT DRAWINGS SUBMITTED FOR PROJECT TEAM REVIEW

Revision

Issued

File Name: 195601220\_GEN-NOTES  
P.E. STEPHEN R. BUSHEY

Permit-Seal

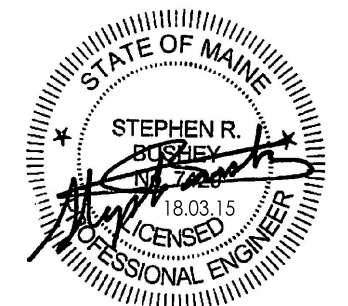

Client/Project  
ROXWIND LLC

ROXBURY WIND PROJECT

ROXBURY TOWNSHIP, MAINE

## Title

# GENERAL NOTES AND LEGEND

Project No. 195601220 Scale N.T.S.

Drawing No. Sheet Revision

C-2.0









DRAFT

PERMIT DRAWINGS SUBMITTED FOR PROJECT TEAM REVIEW	EPL	SRB	18.03.09
Revision	By	Appd.	YY.MM.DD

Issued	By	Appd.	YY.MM.DD
--------	----	-------	----------

File Name:	195601220_DETAILS	KAB	SRB	SRB	18.03.04
P.E.:	STEPHEN R. BUSHEY	Dwn.	Chkd.	Dign.	YY.MM.DD

Permit-Seal

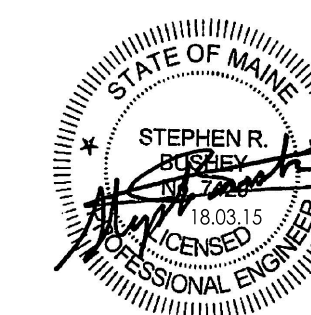

Client/Project  
ROXWIND LLC

ROXBURY WIND PROJECT

ROXBURY TOWNSHIP, MAINE

Title

BACK SLOPE DETAILS

Project No.	Scale
195601220	AS NOTED
Drawing No.	Sheet
	Revision

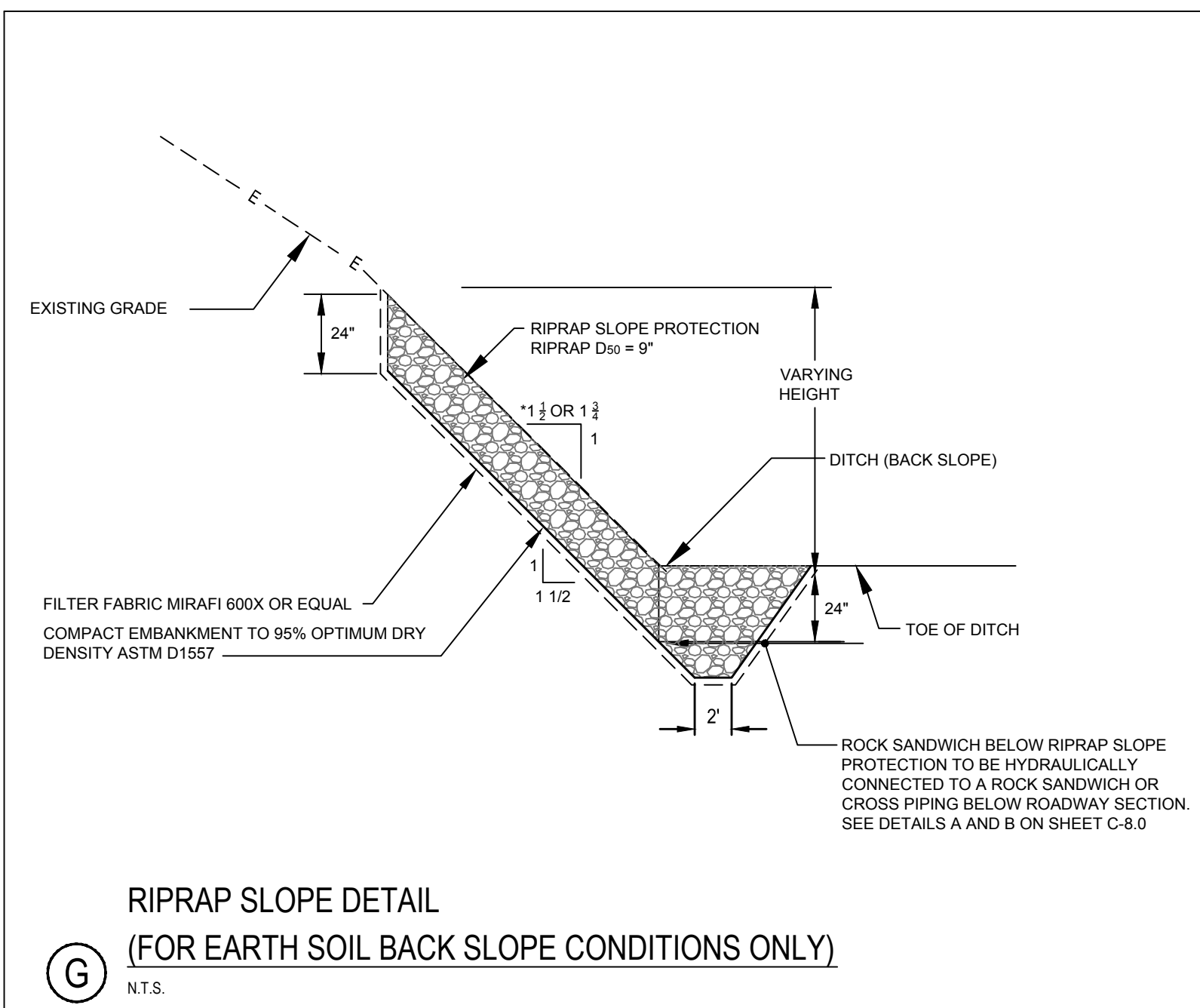
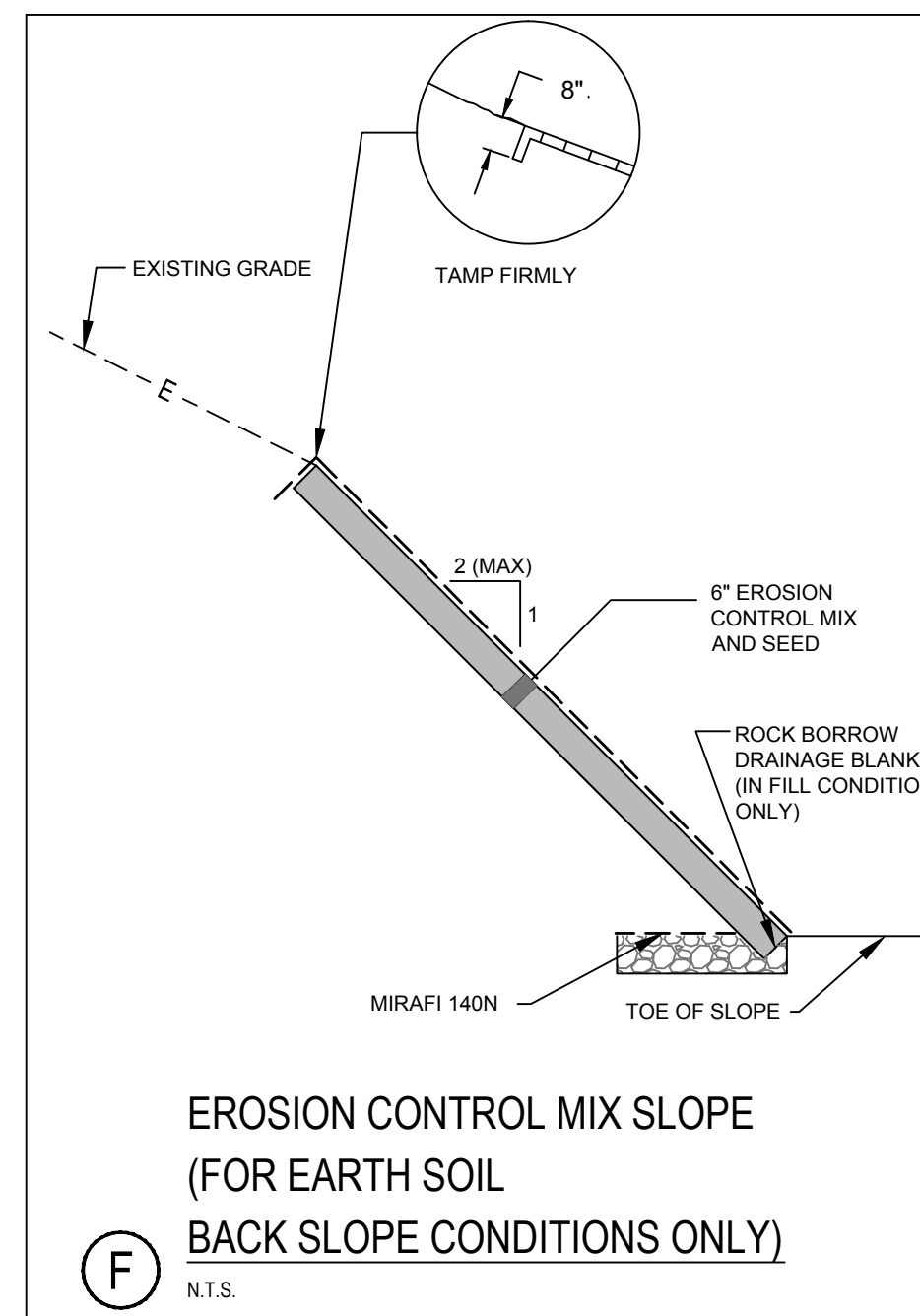
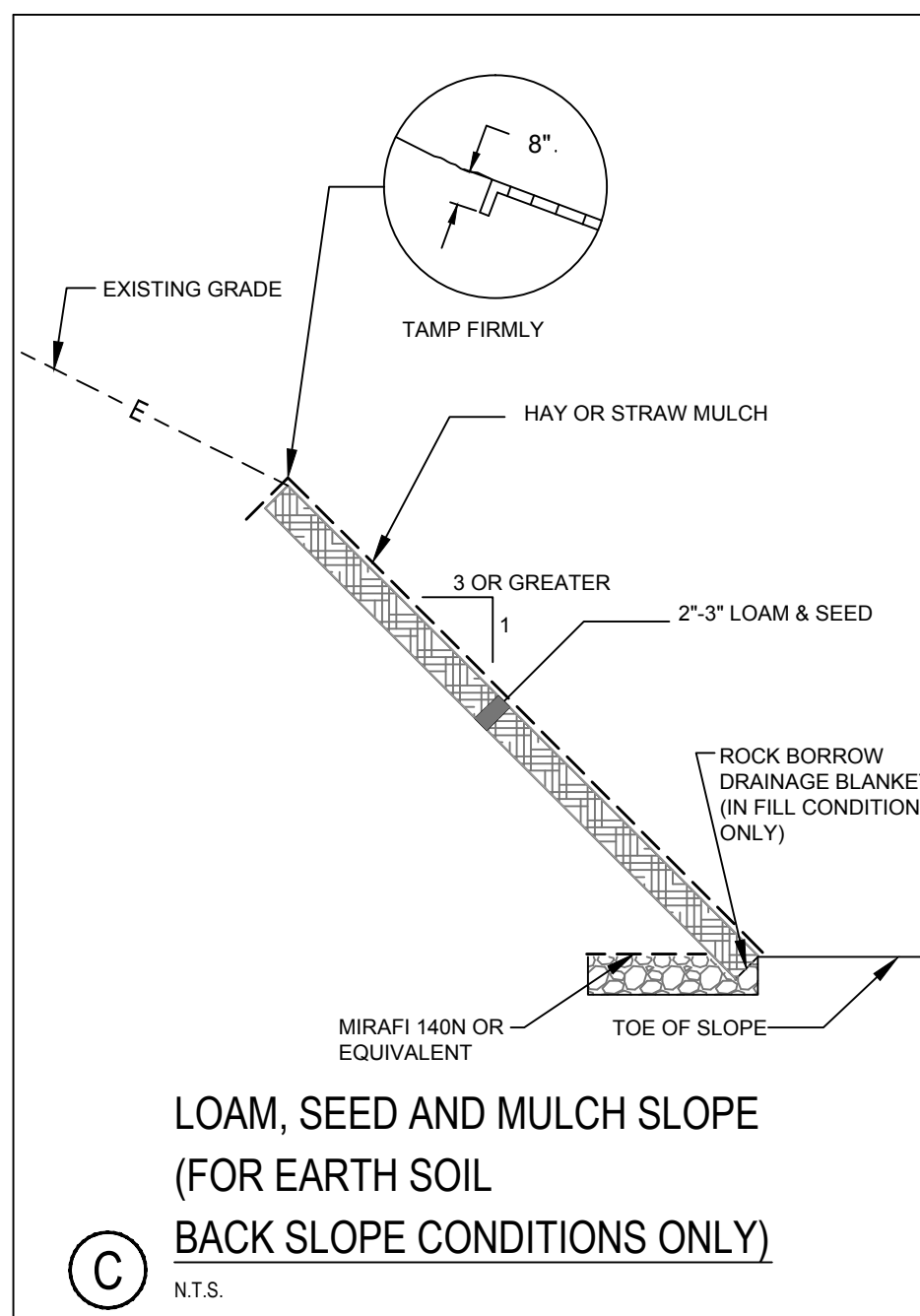
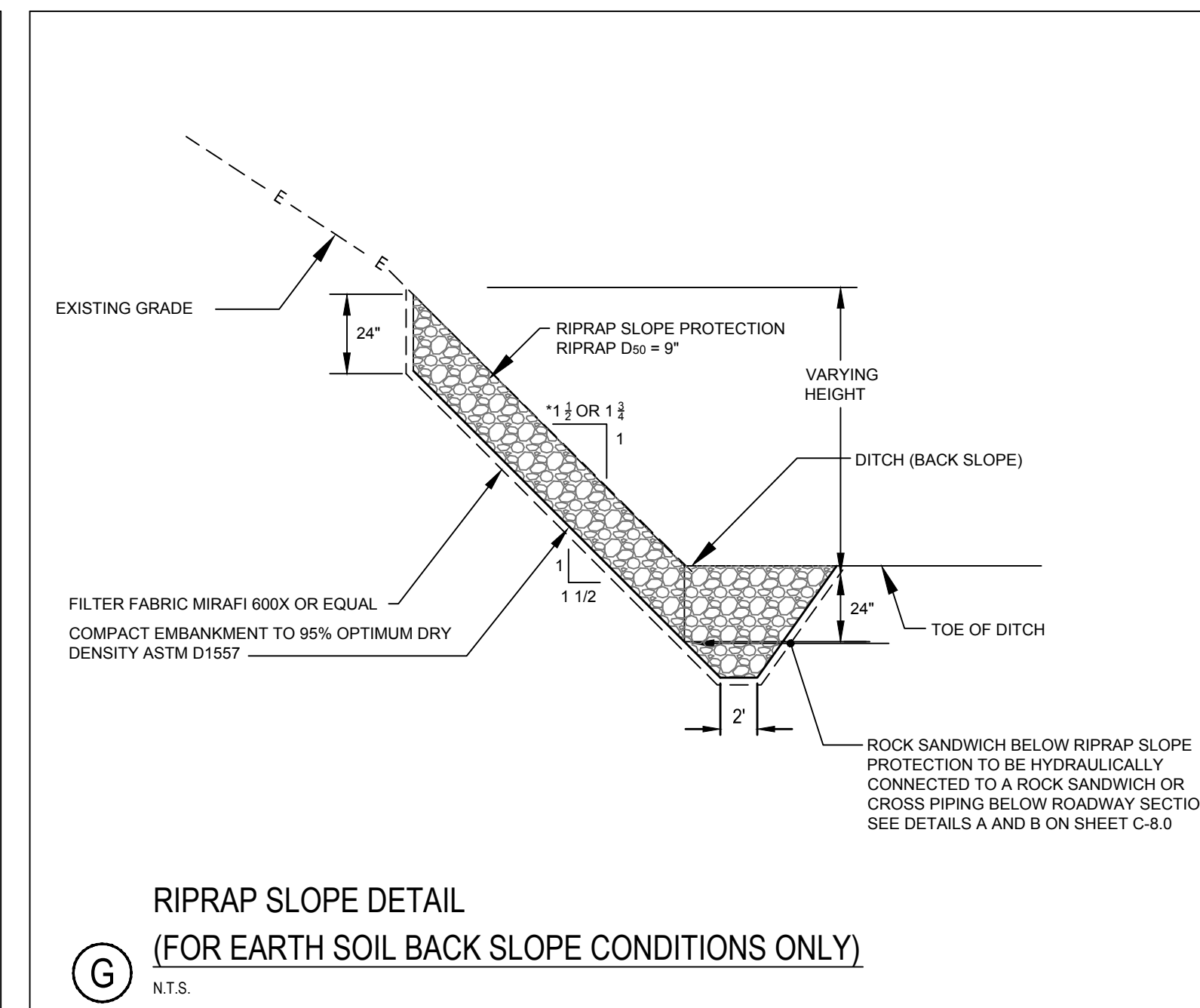

CONDITION	Sr	Sw	S	LOAM SEED AND MULCH	EROSION CONTROL MIX	STONE FACE	RIPRAP	EXPOSED ROCK	ALT. MEASURES TO BE DETERMINED BY GEOTECHNICAL ENGINEER
ABOVE WATER TABLE	N/A	N/A	<1:1	--	--	--	--	--	X
ABOVE ROCK	N/A	N/A	1.75:1	--	--	--	X	--	--
	N/A	N/A	2:1	--	X	X	--	--	--
	N/A	N/A	3:1	--	X	X	--	--	--
ABOVE WATER TABLE W/ ROCK	1:1	N/A	1:1	--	--	--	--	X	--
	1:1	N/A	1.5 to 1.75:1	--	--	--	--	X	--
	1:1	N/A	2:1	--	--	--	--	X	--
	1:1	N/A	3:1	--	--	--	--	X	--
	1:1	N/A	>3:1	--	--	--	--	X	--
BELOW WATER TABLE, ABOVE ROCK (DRAINAGE LAYER OR PIPING REQUIRED)	N/A	Varies	1:1	--	--	--	--	--	X
	N/A	Varies	1.5 to 1.75:1	--	--	--	--	X	--
	N/A	Varies	2:1	--	--	--	X	--	--
	N/A	Varies	3:1	--	--	--	X	--	--
	N/A	Varies	>3:1	--	--	--	X	--	--
BELOW WATER TABLE WITH ROCK	1:1	Varies	1:1	--	--	--	--	X	--
	1:1	Varies	1.5 to 1.75:1	--	--	--	--	X	--
	1:1	Varies	2:1	--	--	--	--	X	--
	1:1	Varies	3:1	--	--	--	--	X	--
	1:1	Varies	>3:1	--	--	--	--	X	--

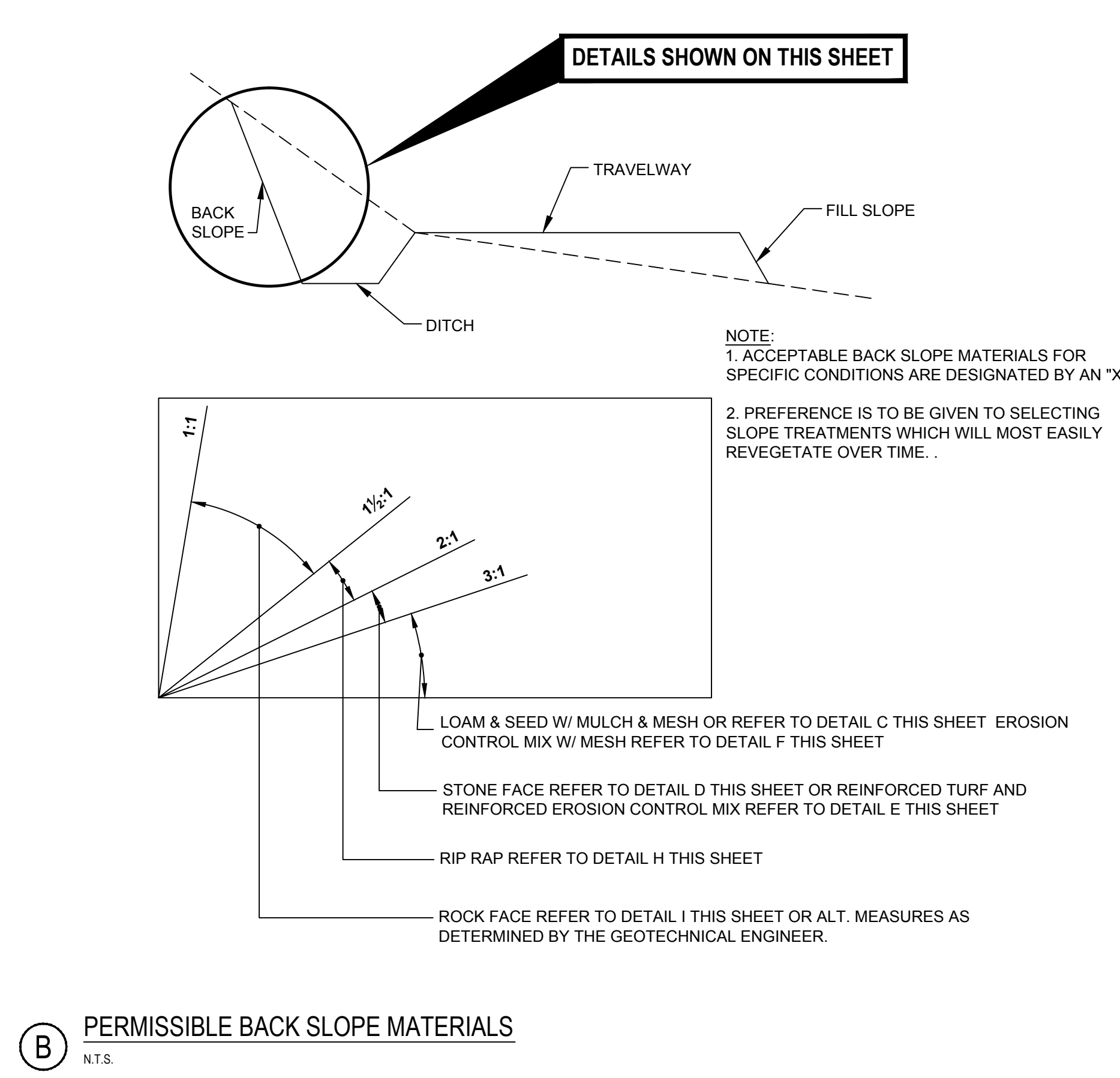
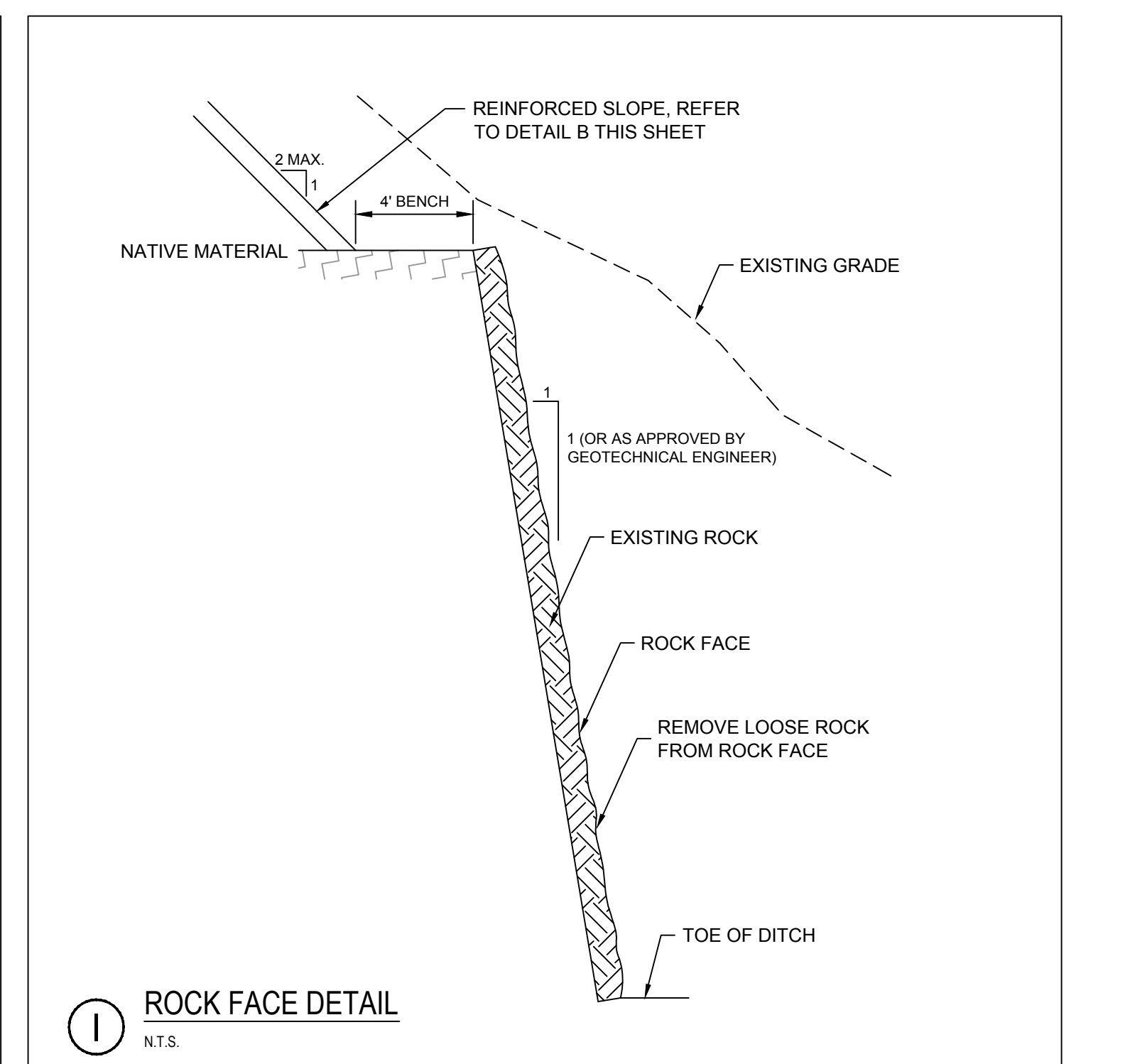
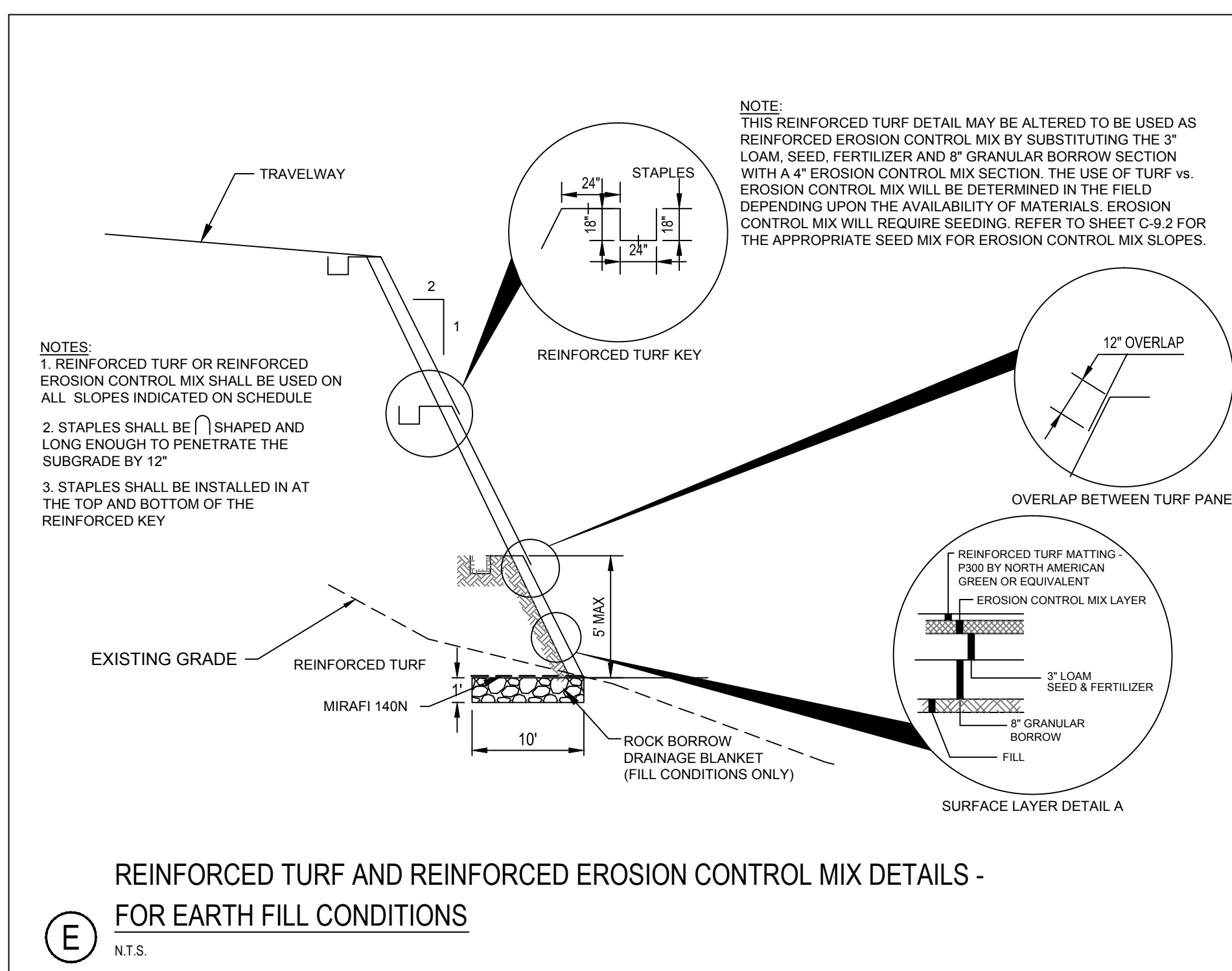
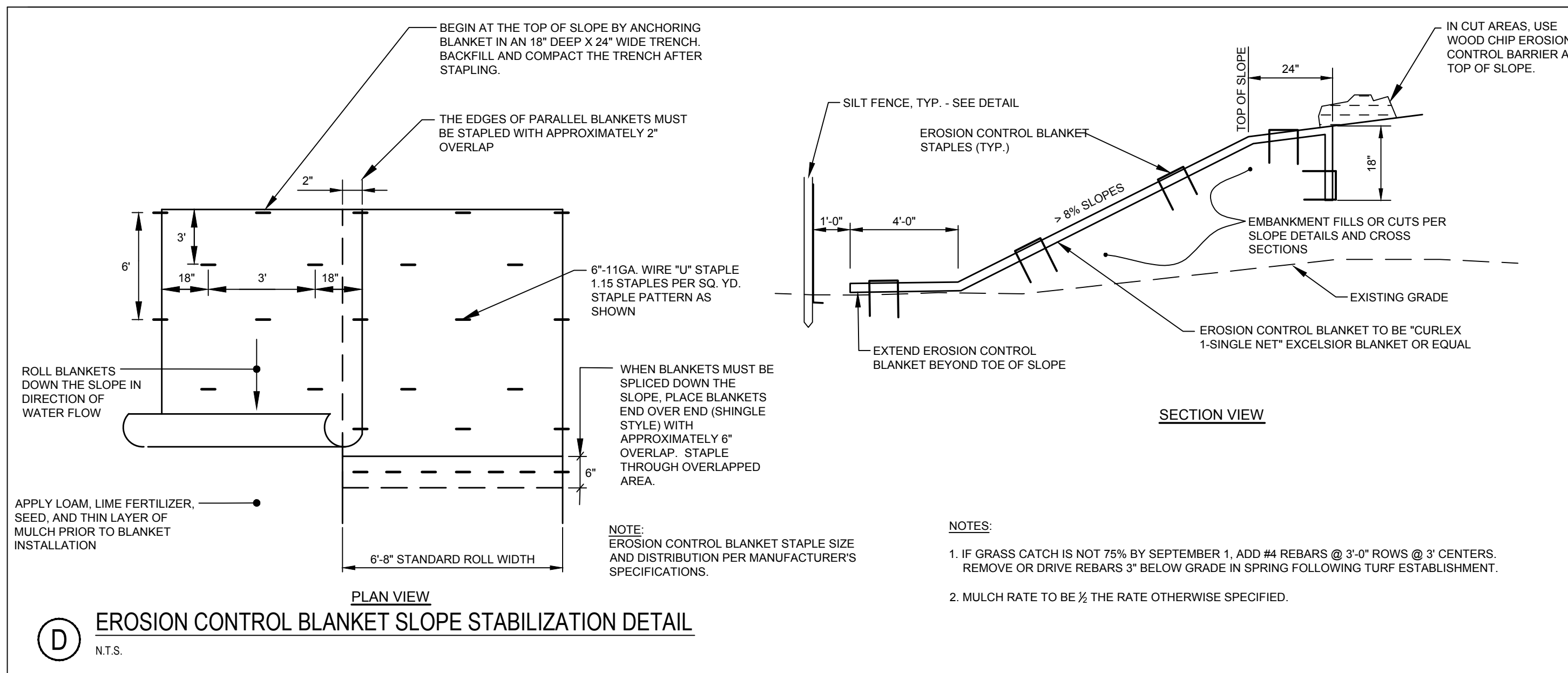

DRAFT

PERMIT DRAWINGS SUBMITTED FOR PROJECT TEAM REVIEW	EPL	SRB	18.03.09
Revision	By	Appd.	YY.MM.DD

Issued By Appd. YY.MM.DD

File Name: 195601220\_DETAILS KAB SRB SRB 18.03.04  
P.E. STEPHEN R. BUSHEY Dwn. Crkd. Dgrn. YY.MM.DD

Permit-Seal

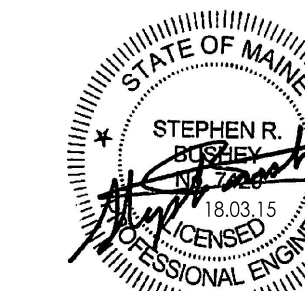

Client/Project  
ROXWIND LLC

ROXBURY WIND PROJECT  
ROXBURY TOWNSHIP, MAINE

Title

DITCH AND CULVERT DETAILS

Project No. 195601220 Scale AS NOTED  
Drawing No. Sheet Revision

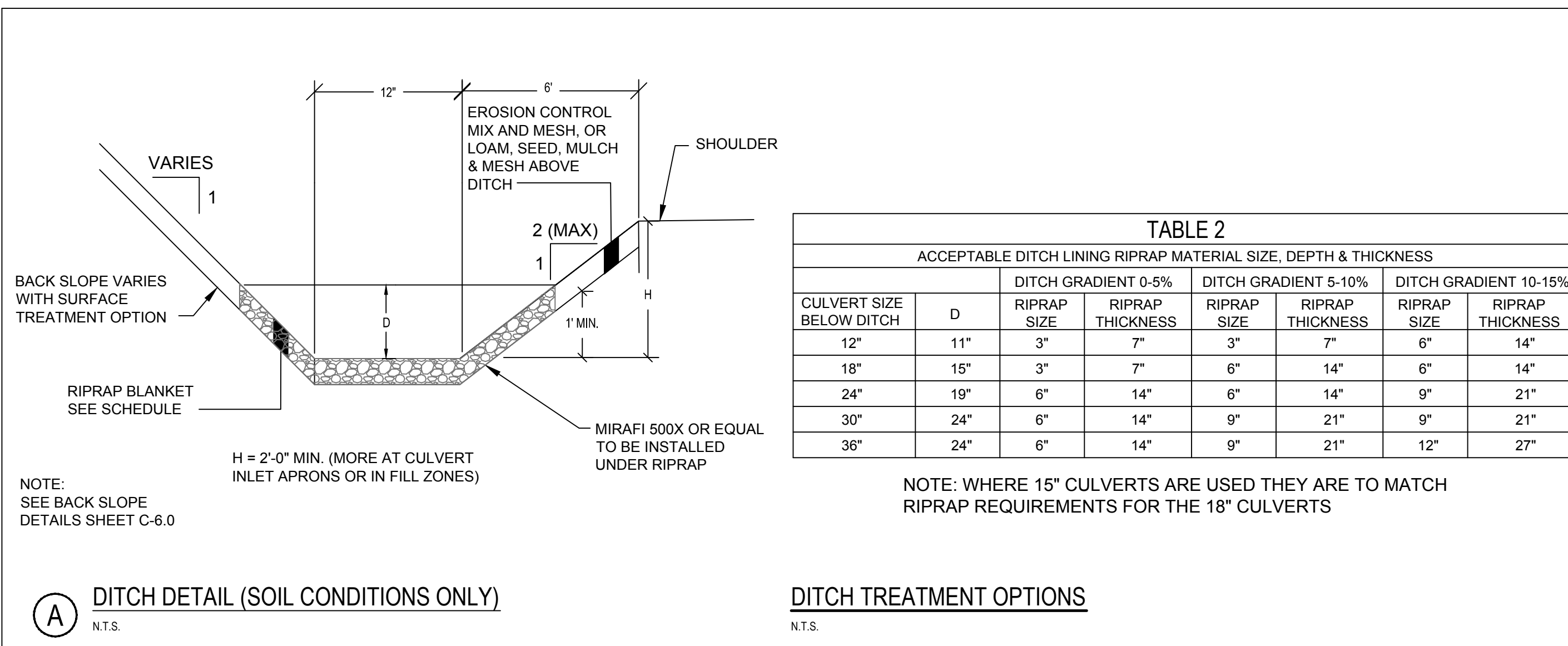

A DITCH DETAIL (SOIL CONDITIONS ONLY)  
N.T.S.

DITCH TREATMENT OPTIONS  
N.T.S.

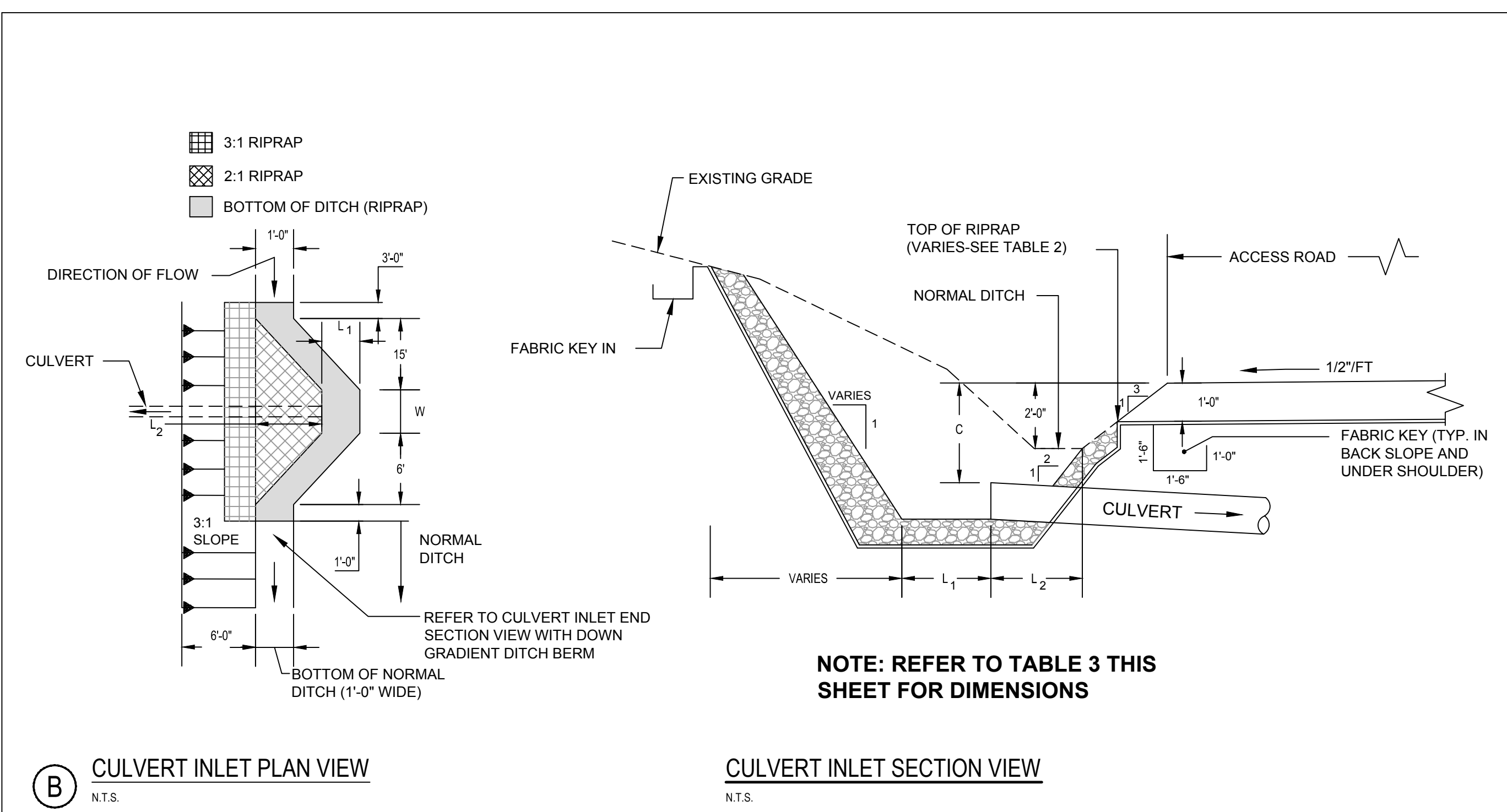

B CULVERT INLET PLAN VIEW  
N.T.S.

CULVERT INLET SECTION VIEW  
N.T.S.

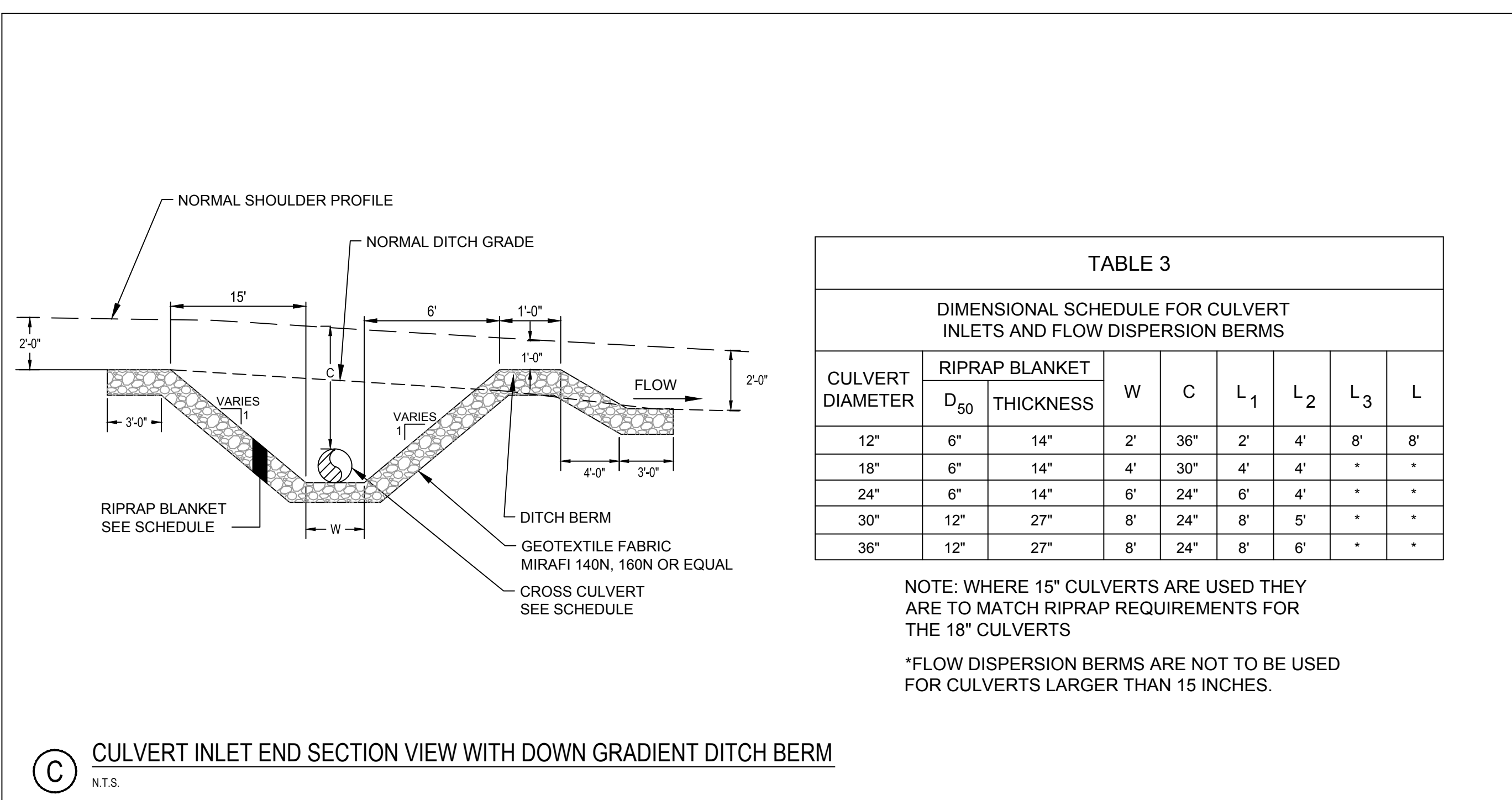

C CULVERT INLET END SECTION VIEW WITH DOWN GRADIENT DITCH BERM  
N.T.S.

CULVERT DIAMETER	RIPRAP BLANKET		W	C	L <sub>1</sub>	L <sub>2</sub>	L <sub>3</sub>	L
	D <sub>50</sub>	THICKNESS						
12"	6"	14"	2'	36"	2'	4'	8'	8'
18"	6"	14"	4'	30"	4'	4'	*	*
24"	6"	14"	6'	24"	6'	4'	*	*
30"	12"	27"	8'	24"	8'	5'	*	*
36"	12"	27"	8'	24"	8'	6'	*	*

NOTE: WHERE 15" CULVERTS ARE USED THEY ARE TO MATCH RIPRAP REQUIREMENTS FOR THE 18" CULVERTS

\*FLOW DISPERSION BERMS ARE NOT TO BE USED FOR CULVERTS LARGER THAN 15 INCHES.

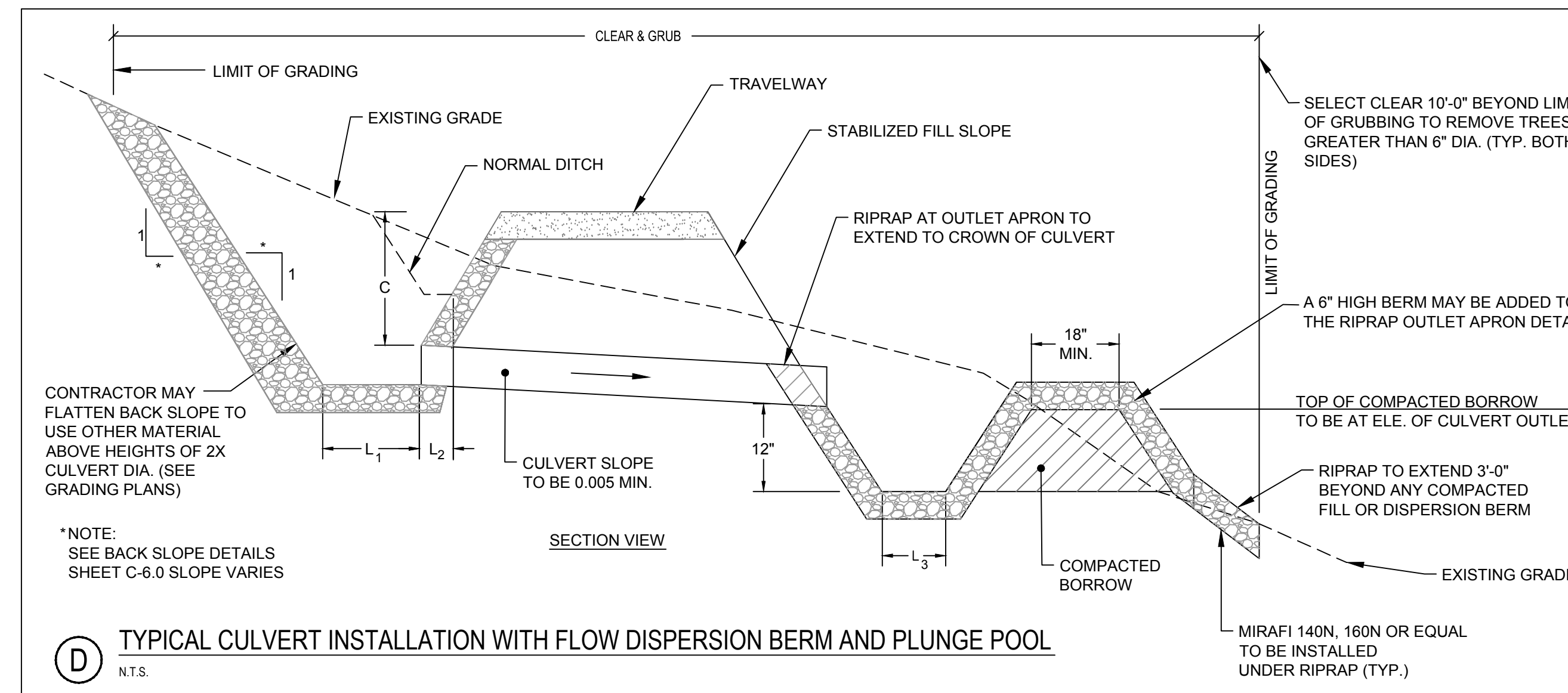

D TYPICAL CULVERT INSTALLATION WITH FLOW DISPERSION BERM AND PLUNGE POOL  
N.T.S.

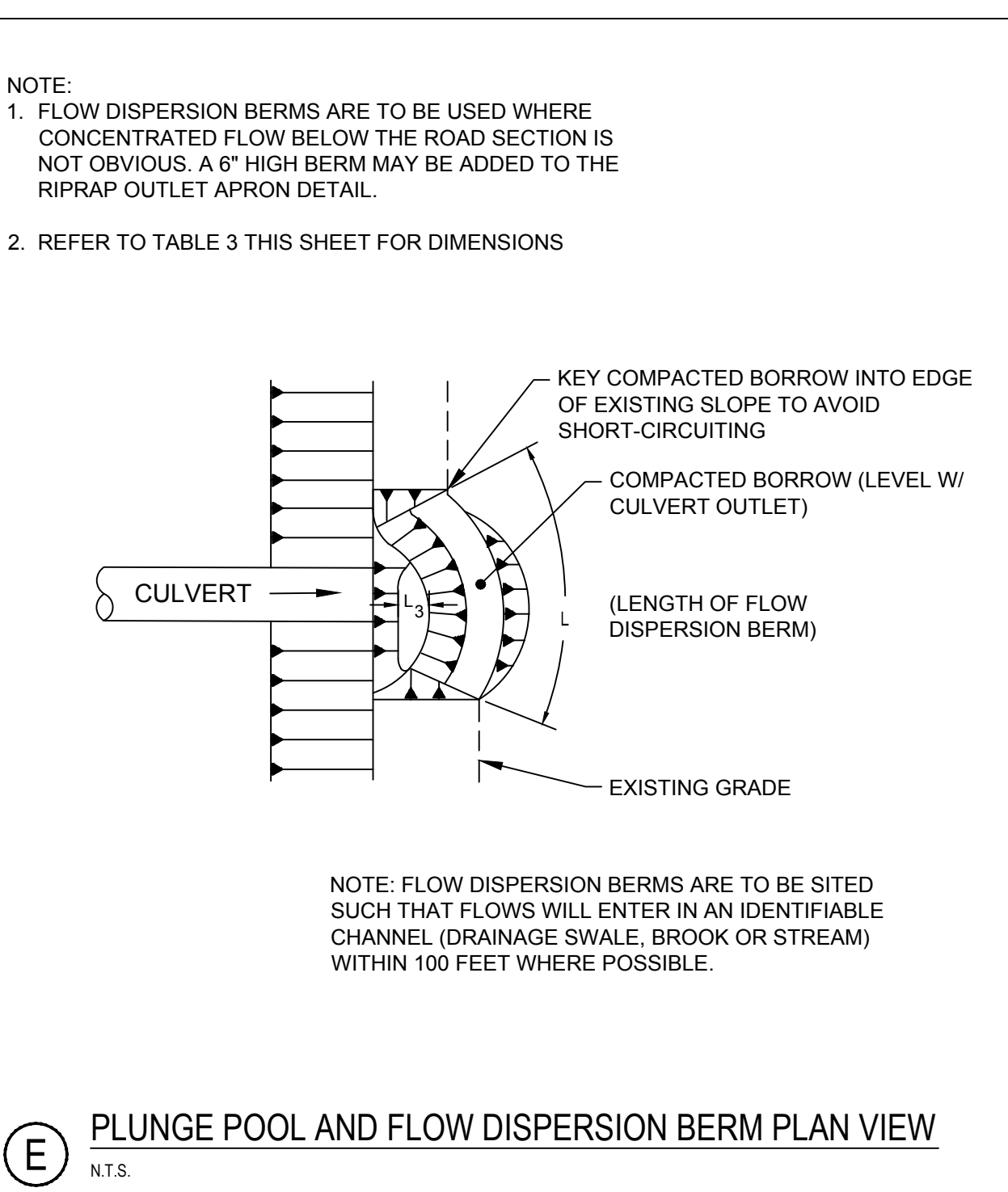

E PLUNGE POOL AND FLOW DISPERSION BERM PLAN VIEW  
N.T.S.

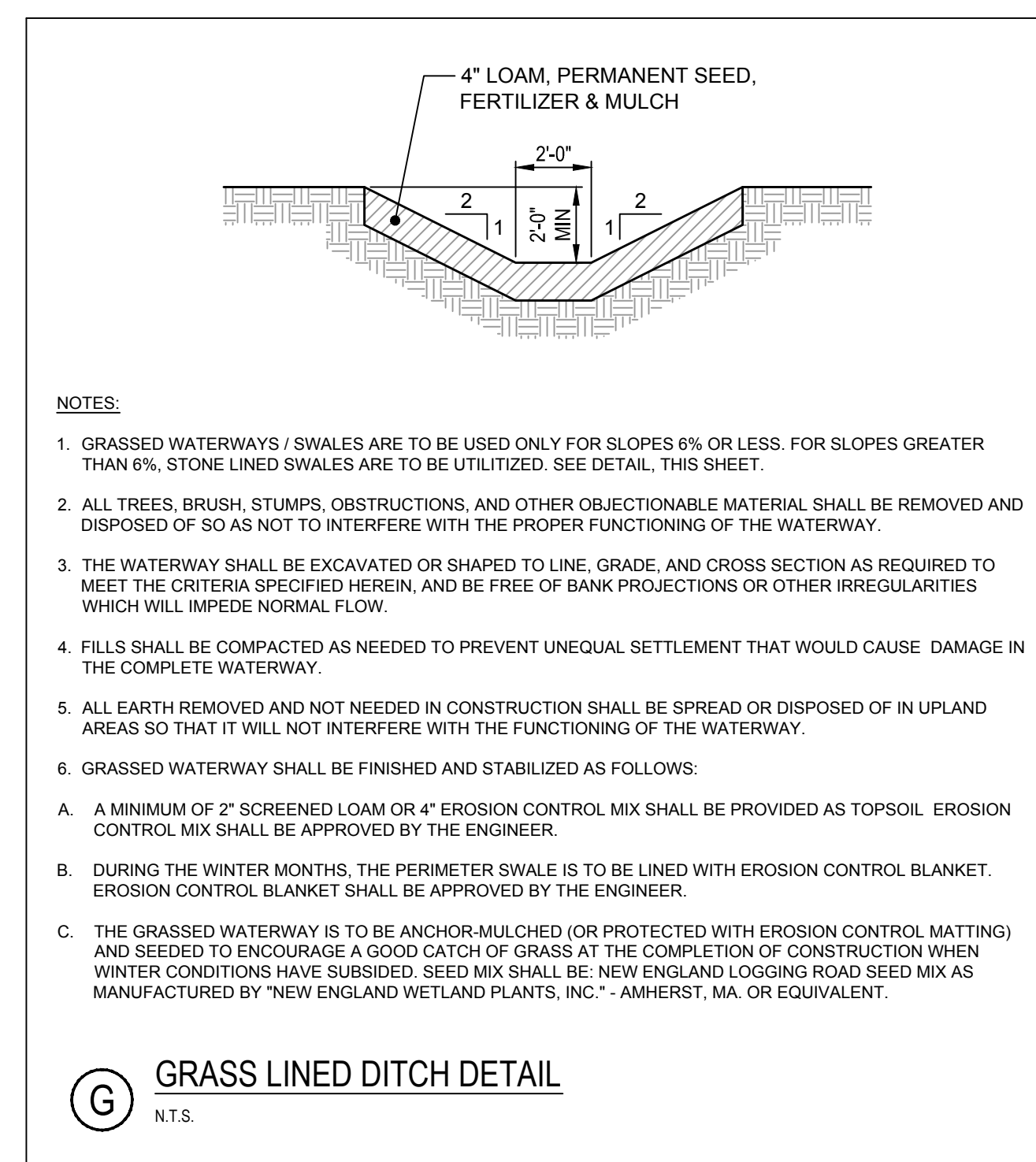

G GRASS LINED DITCH DETAIL  
N.T.S.

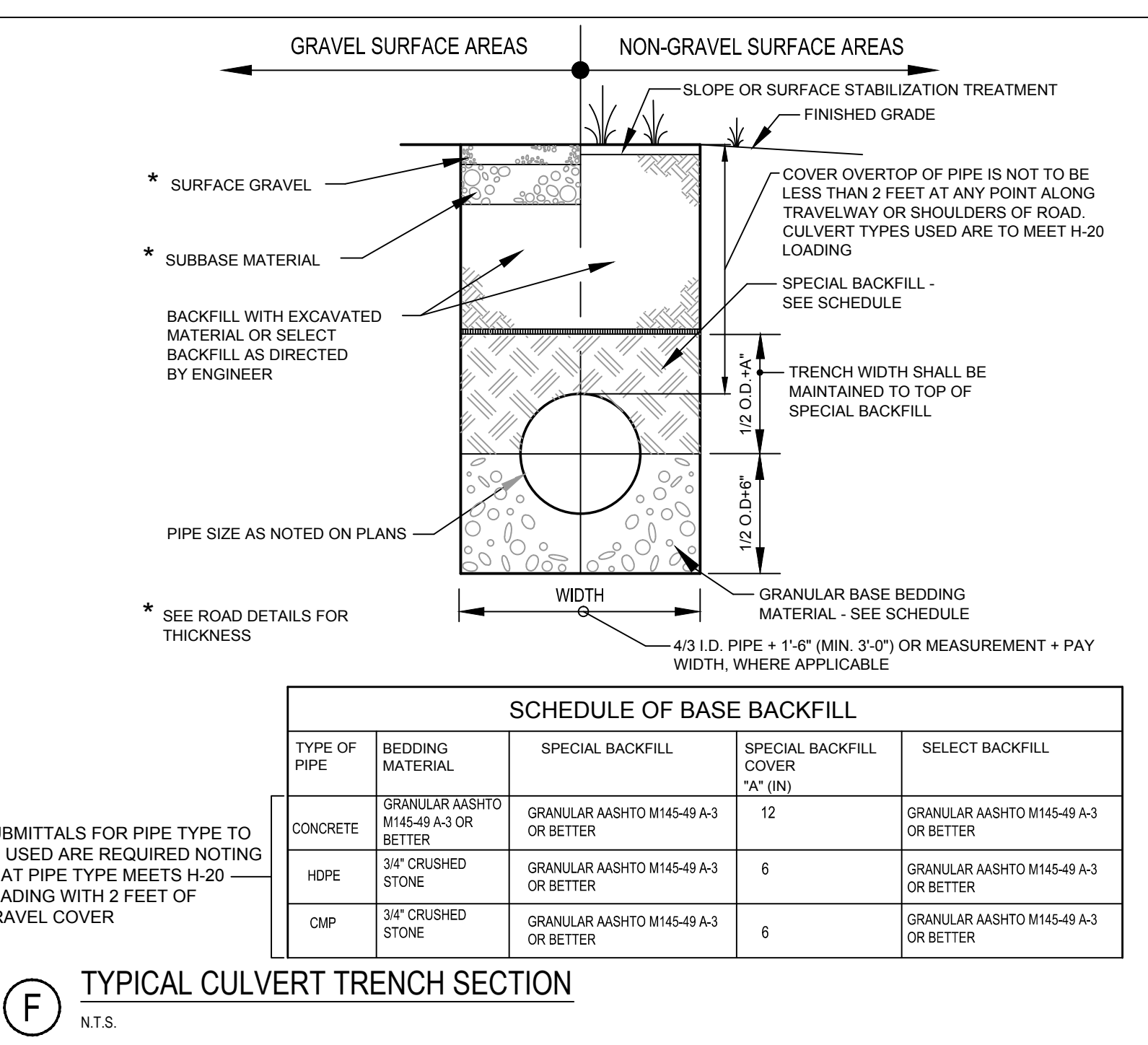

F TYPICAL CULVERT TRENCH SECTION  
N.T.S.





DRAFT

PERMIT DRAWINGS SUBMITTED FOR PROJECT TEAM REVIEW EPL SRB 18.03.09  
Revision By Appd. YF.XM.DD

Issued By Appd. YF.XM.DD

File Name: 195601220\_DETAILS KAB SRB 18.03.04  
P.E. STEPHEN R. BUSHEY Dwn. Chkd. Dgnr. YF.XM.DD

Permit-Seal

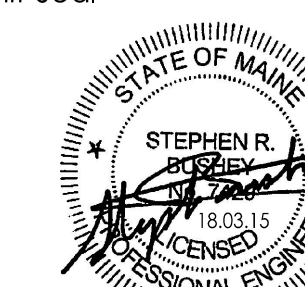

Client/Project  
ROXWIND LLC

ROXBURY WIND PROJECT  
ROXBURY TOWNSHIP, MAINE

Title  
EROSION CONTROL DETAILS

Project No. 195601220 Scale AS NOTED

Drawing No. Sheet Revision

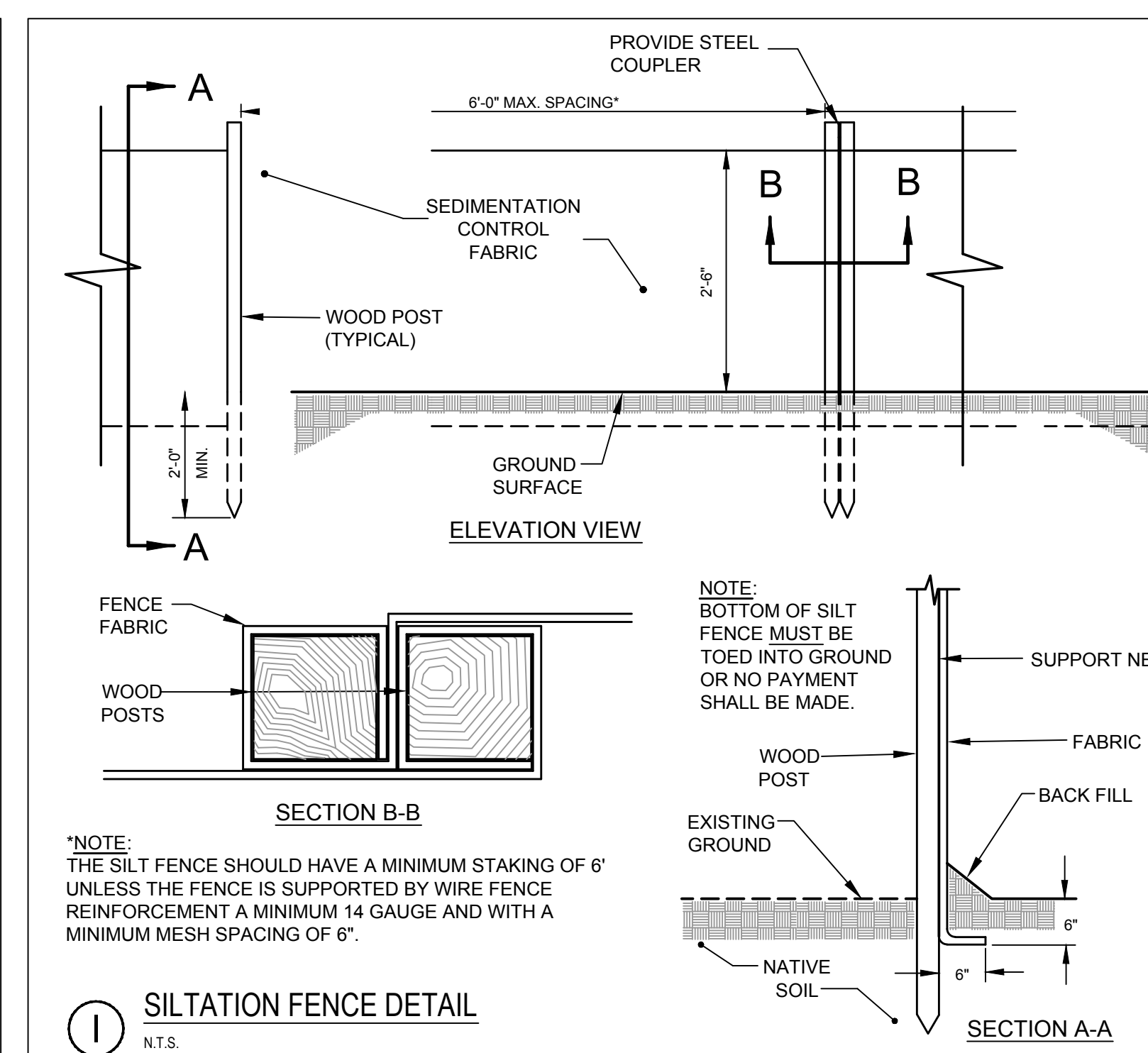
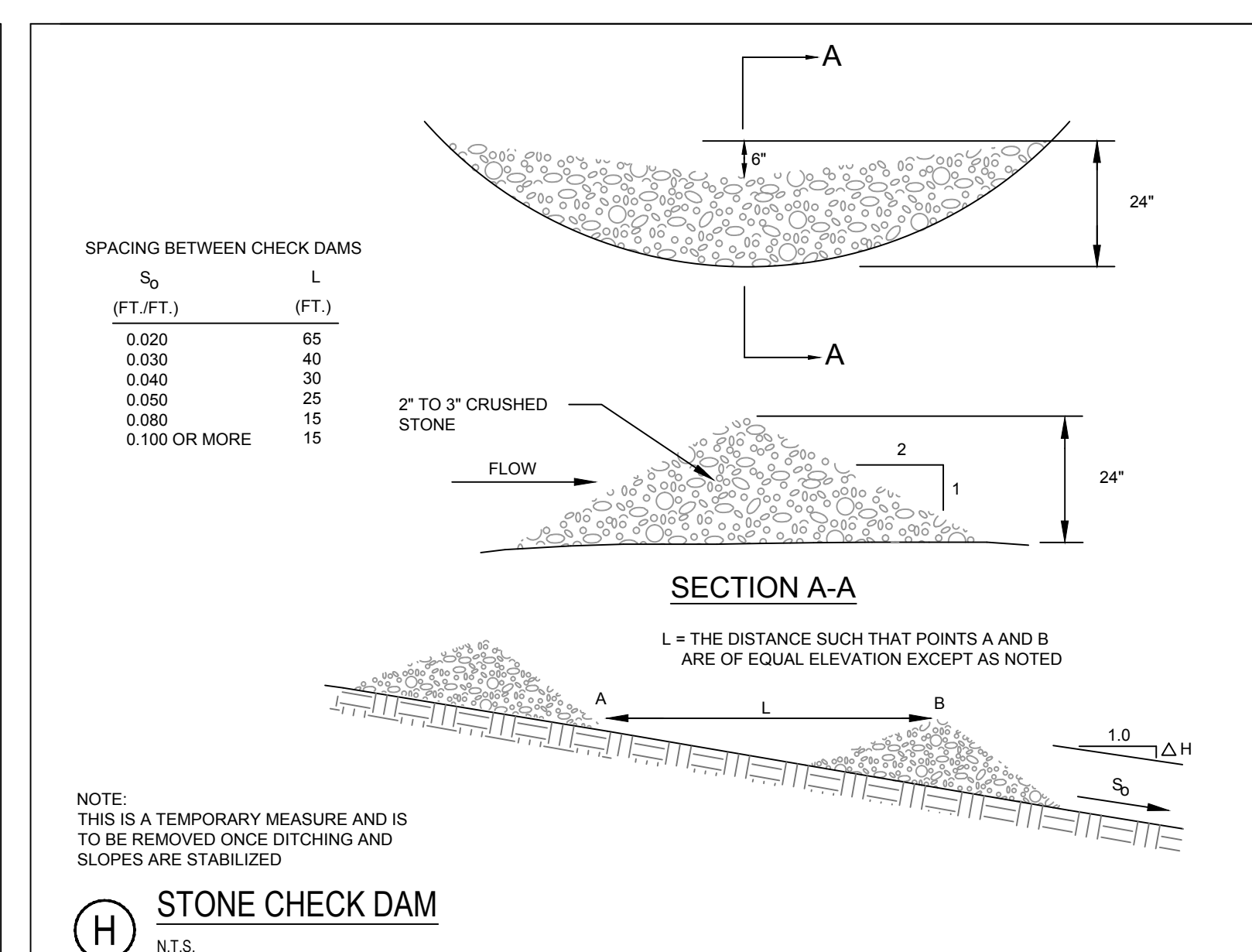
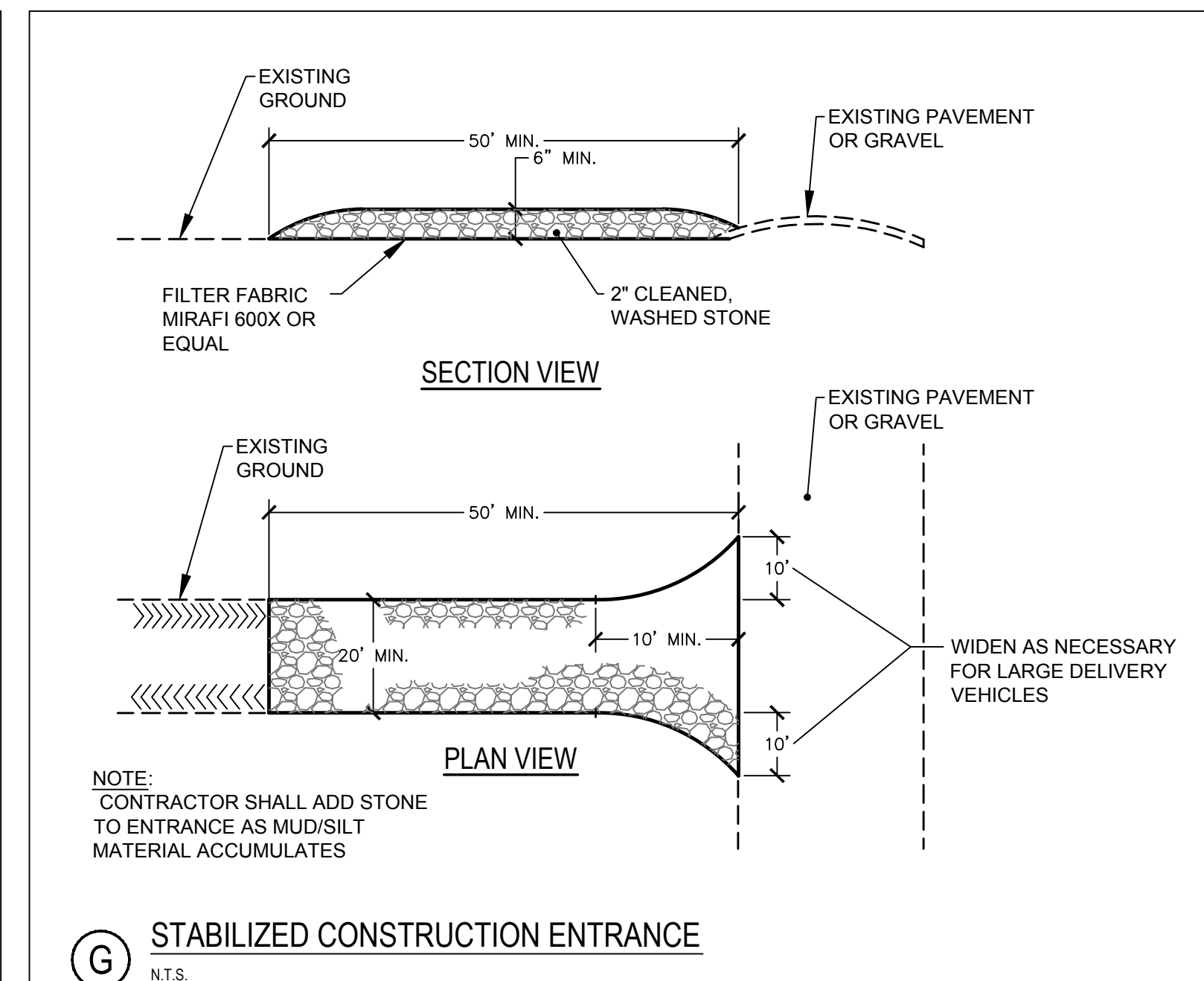
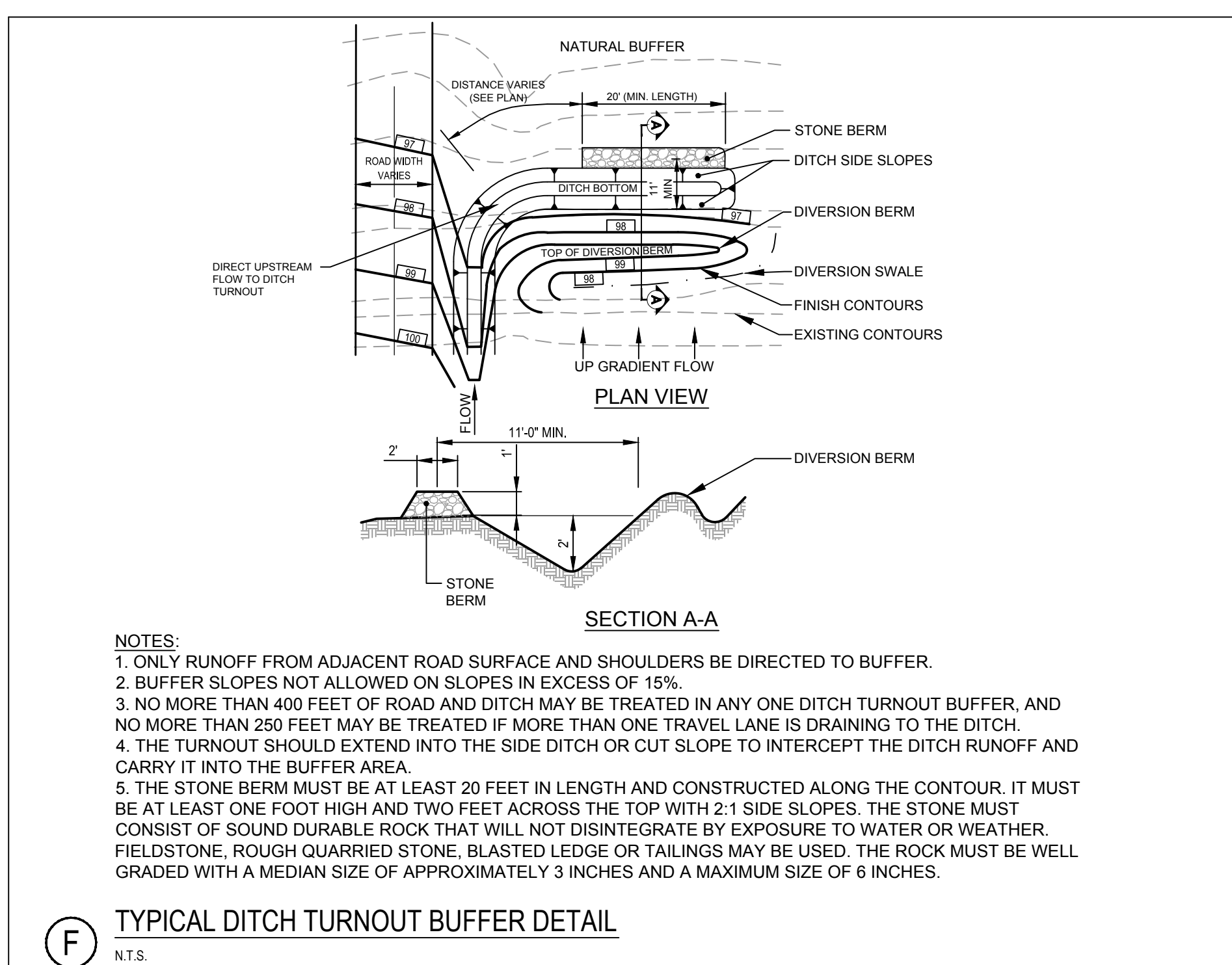
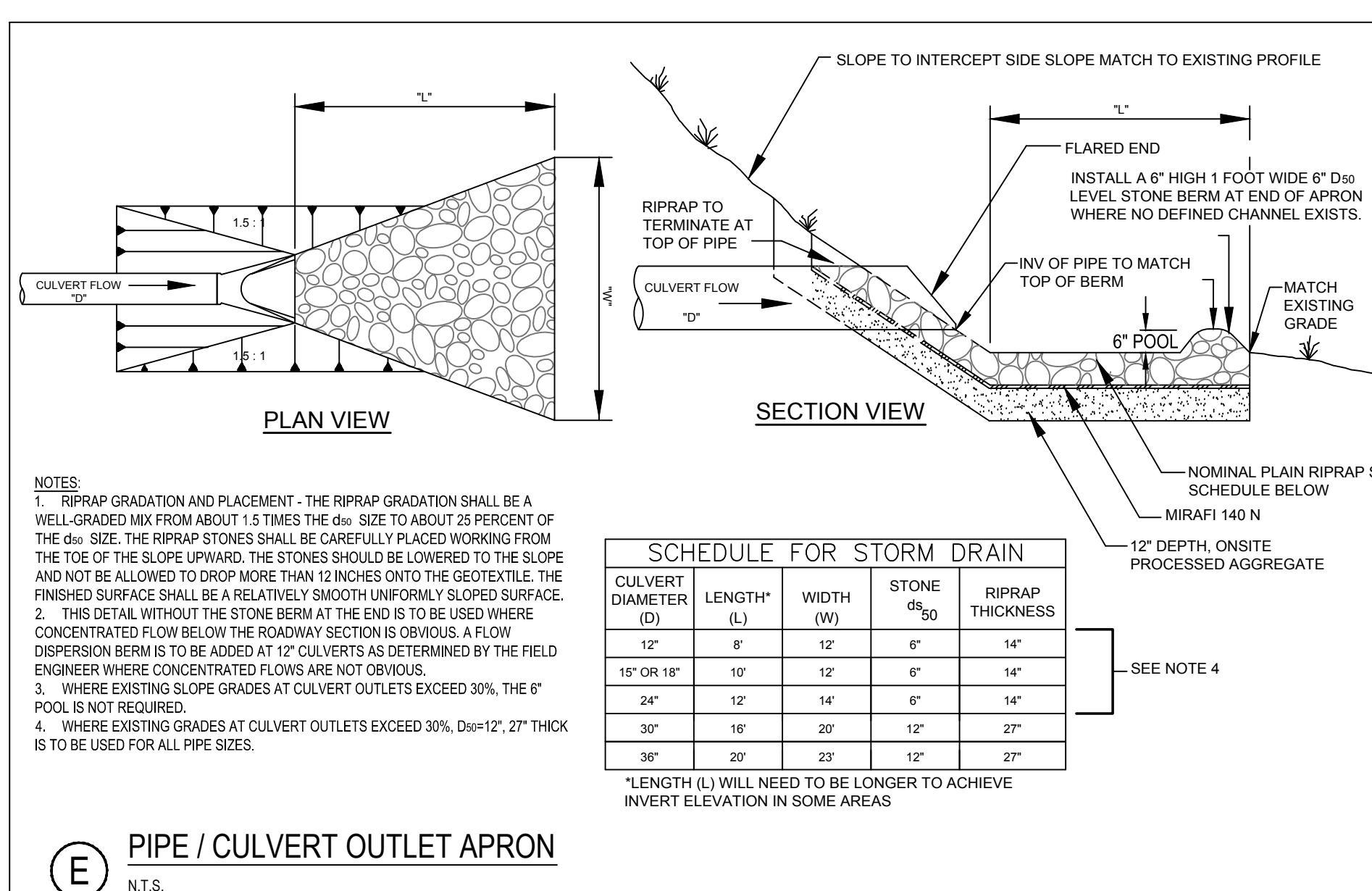
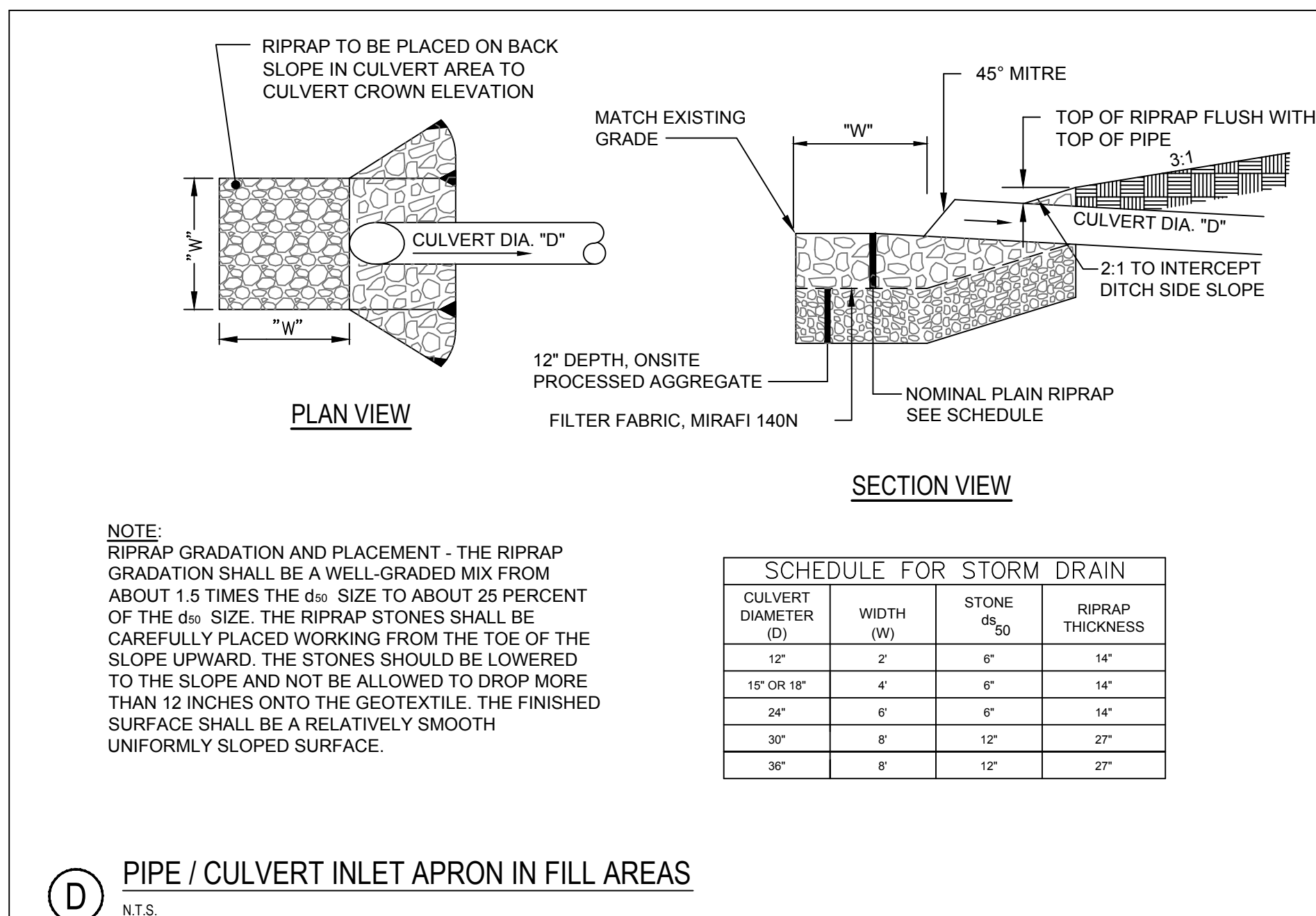
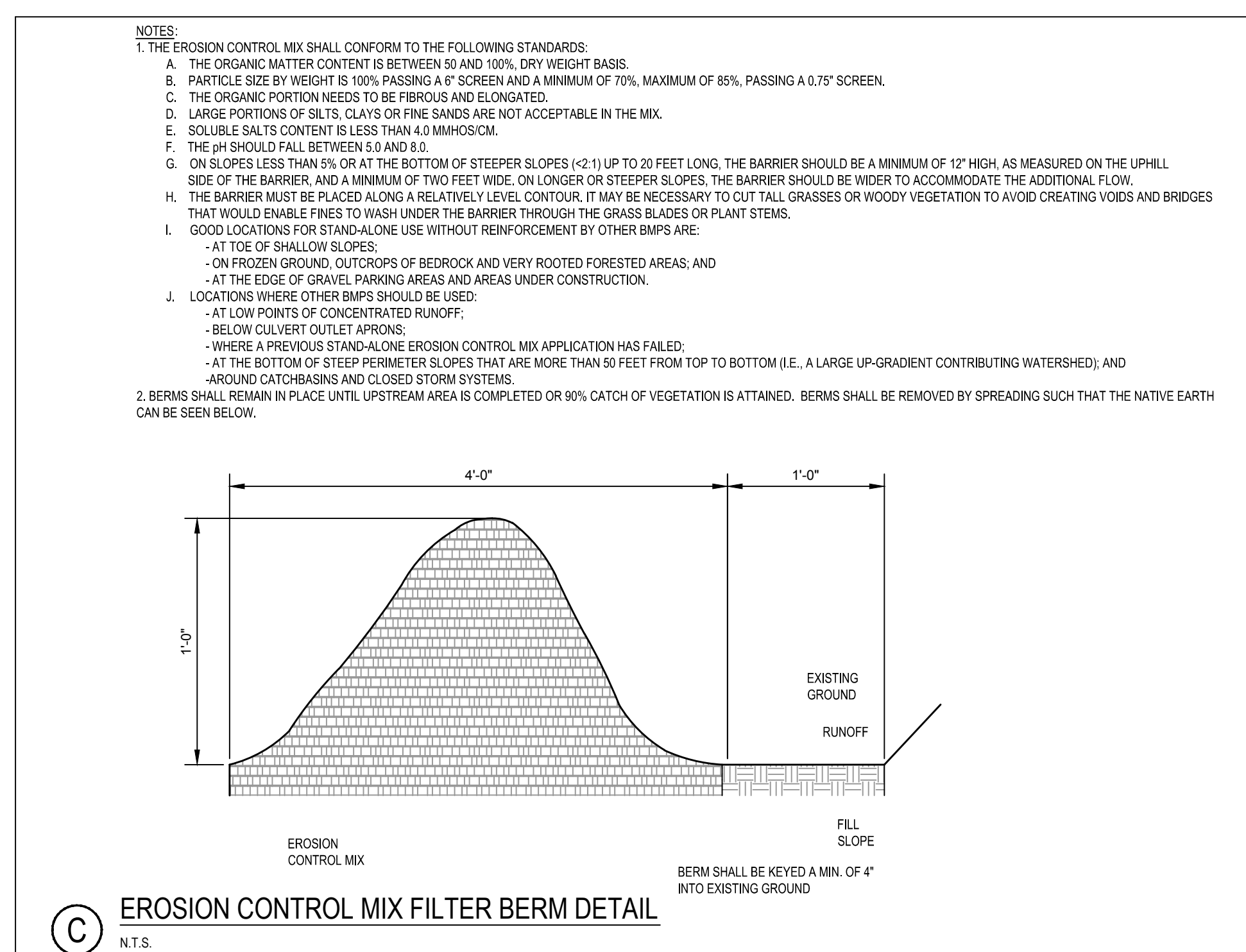
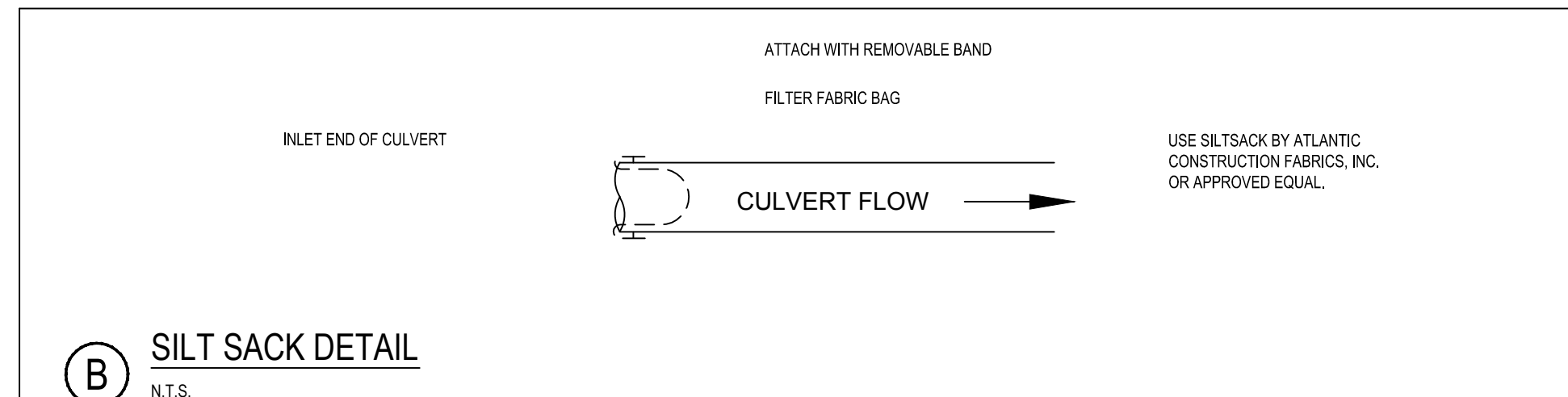
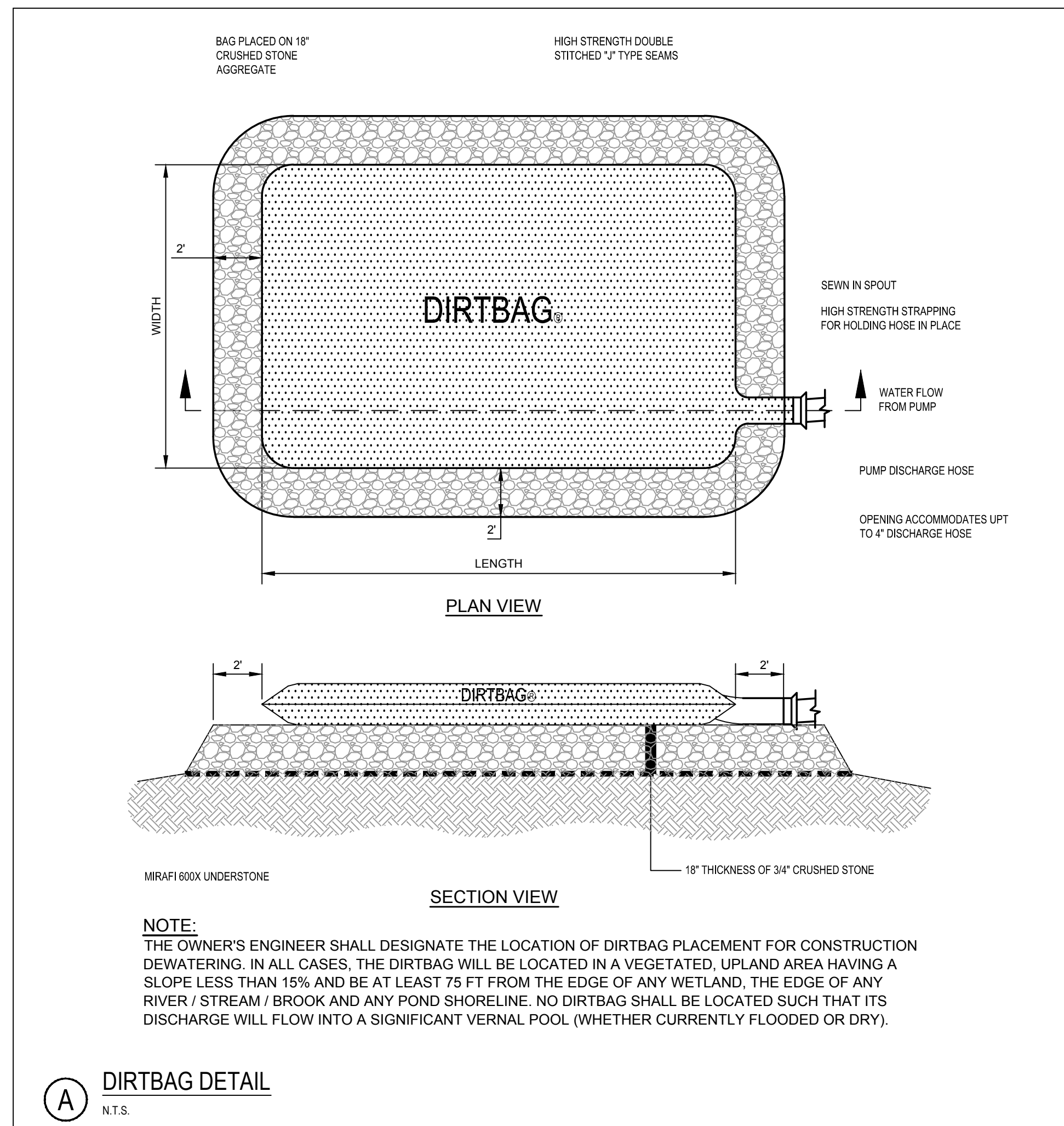







# DRAFT

- Permanent seeding shall not be attempted during the fall or winter seasons unless otherwise approved by the Engineer. Should seeding be approved by the Engineer during fall or winter seasons, the Contractor shall follow procedures for dormant seeding. See *Permanent Seeding and Mulching Plan* above for dormant seeding requirements. However, vegetation must be inspected and reseeded by Contractor as necessary in the following spring to ensure good vegetative cover. Acceptance of dormant seeding shall not occur until after May 1, in the following spring.
- Temporary seeding and mulch shall be inspected and maintained or repaired weekly. At a minimum, 75 percent of the soil surface should be covered by vegetation. If any evidence of erosion or sedimentation is apparent, repairs shall be made and other temporary measures used in the interim (e.g., mulch, filter barriers, check dams, bales). Mulch shall be reapplied as necessary to completely cover soil.
- Areas within 75 feet of a protected natural resource shall be stabilized with temporary mulching or temporary seeding with mulching and have a sediment barrier installed between the area and resource within 48 hours or prior to any storm event, whichever occurs first.

**Ditch Stabilization Plan** - Any section of rough-graded ditch will have stone check dams installed in the ditch within 24 hours to prevent ditch scouring. Any section of finish-graded ditch will be stabilized with permanent lining of grass and or riprap within 7 days for ditches in non-critical areas and within 48 hours or prior to any storm event, whichever occurs first, for culverts in critical areas.

**Inlet and Outlet Stabilization Plan** - Any drainage structure installed on the project shall have the appropriate inlet and outlet protection installed within 7 days in non-critical areas and within 48 hours or prior to any storm event, whichever occurs first, in critical areas.

STABILIZATION SCHEDULE		
Maximum Expected Interim Period* - (Days)	Temporary Mulching (Hay)	Temporary Seeding
0-7 (0-2)	None	None
7-30 (2-14)	2-bales/1,000 sq.ft	None
30-60 (14-30)	2-bales/1,000 sq.ft.	(per Table 14-2: Temporary Seeding Schedule)
More than 7 days during winter season	4-bales/1,000 sq.ft.	Dormant seeding only

\* Values in parentheses indicates interim period for sensitive and critical areas.  
 \*\* Mulch application rates shall be doubled for winter construction.

TEMPORARY SEEDING SCHEDULE			
Seed	Seeding Rate (lbs/1,000 sq. ft.)	Seeding Depth (Inches)	Recommended Seeding Dates
Annual Rye Grass	0.9	1/4	4/1 to 7/1
Sudan Grass	0.9	1/2	7/1 to 8/15
Perennial Rye Grass	1.8	1/4	8/15 to 9/15
Winter Rye Grass	2.6	1	9/15 to 10/15
Dormant Seeding 50% Winter Rye 50% Annual Rye	3.5 (2.6) (0.9)	1	10/15 to 3/31

PERMANENT SEEDING SCHEDULE		
	SEED	PERCENT BY WEIGHT
Upland Areas with Loam Cover	Tall Fescue	35%
	Creeping Red Fescue	30%
	Perennial Ryegrass	20%
	Annual Ryegrass	15%
Upland Areas with Erosion Control Mix Cover	Crown Vetch	50%
	Perennial Lupine	25%
	Crimson Clover	15%
	Annual Rye	10%
Slopes and Ditches Below Water Table or Line of Seepage	Creeping Red Fescue	47%
	Red Top	6%
	Tall Fescue	47%

**Topsail** - Topsoil will be stockpiled on-site when necessary in areas that have minimum potential for erosion, such as flat slopes or on-site borrow pits, and will be kept as far as possible from existing drainage areas. Stockpiles expected to remain longer than 15 days shall be encircled with bales, erosion control mix berms, or silt fence at the down gradient sides of the stockpile and mulched with a second application of hay mulch and anchored with biodegradable netting if deemed necessary by the Engineer (Maine Construction General Permit, Appendix A (6) a-d).

**Winter Construction** - For any work proposed during the winter season, the Contractor shall adhere to the following practices.

- Limit the exposed area to those areas in which work is to occur during the following 15 days and that can be mulched in one day prior to any snow event.
- Where required and approved by the Engineer, installation of silt fence may be modified from detail on design plans to substitute six inches of suitable non-organic material over the bottom of the silt fence in lieu of trenching and backfilling fabric or erosion control mix berm/barrier.
- Mulching and seeding rates shall adhere to the *Temporary Seeding and Mulching Schedule* above. Note that all mulching rates shall be doubled as shown in the above table and shall follow the sensitive area schedule during winter construction.
- Permanent seeding shall not be attempted by the Contractor during winter season unless otherwise approved by the Engineer.

### 5.2 Erosion Control Removal

Removal of temporary erosion control measures shall be the responsibility of the Contractor. Erosion controls shall remain in place and will be maintained by the Contractor until all related construction is complete and the area has been stabilized. Erosion control mix will be used to revegetate roads/pads and should be left in place.

An area is considered stable if a 90 percent cover of vegetation has been established or riprap or other permanent measures are in place and functioning properly.

Bales and silt fence shall be removed within 30 days of final stabilization. The bales and silt fence shall be disposed of legally and properly off-site. Sediment trapped behind these controls shall be distributed to an area undergoing final grading and graded in an aesthetic manner to conform to the topography, and fertilized, seeded and mulched, or otherwise stabilized, in accordance with the rates previously stated.

The sediment trapped behind/around/in stone check dams, perforated risers, and sedimentation basins, shall be removed and transported off-site, or to an upslope area undergoing final grading. The sediment trapped by these devices shall not be regraded locally since they exist in drainage ways.

The rip-rap and stone from the check dams and risers may be either removed or regraded in an aesthetic manner that does not inhibit flow or create the potential for erosion.

Once the trapped sediments have been removed from the temporary sedimentation devices, the disturbed areas will be loamed (if necessary), fertilized, seeded and mulched, or otherwise stabilized, in accordance with the rates previously stated.

### 6.0 Conclusion

If constructed in conformance with the project design plans and these basic standards, the project is not expected to result in any significant erosion or sedimentation either on or off the site.

PERMIT DRAWINGS SUBMITTED FOR PROJECT TEAM REVIEW	EP	SRB	18.03.09
Revision	By	Appd.	YY.MM.DD
Issued	By	Appd.	YY.MM.DD

File Name:	195601220_DETAILS	KAB	SRB	SRB	18.03.04
	P.E. STEPHEN R. BUSHEY	Dwn.	Chkd.	Dsgn.	YY.MM.DD

Permit-Seal

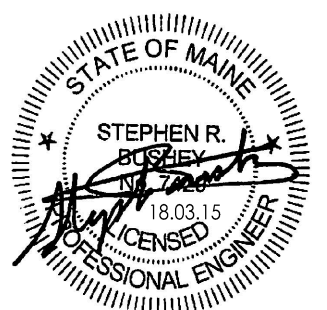

Client/Project  
 ROXWIND LLC

ROXBURY WIND PROJECT

ROXBURY TOWNSHIP, MAINE

Title

**EROSION CONTROL NOTES**

Project No. 195601220	Scale AS NOTED
Drawing No.	Sheet Revision

DRAFT

PERMIT DRAWINGS SUBMITTED FOR PROJECT TEAM REVIEW	EPL	SRB	18.03.09
Revision	By	Appd.	YY.MM.DD

Issued	By	Appd.	YY.MM.DD
--------	----	-------	----------

File Name: 195601220_DETAILS	KAB	SRB	SRB	18.03.04
P.E. STEPHEN R. BUSHHEY	Dwn.	Chkd.	Dign.	YY.MM.DD

Permit-Seal

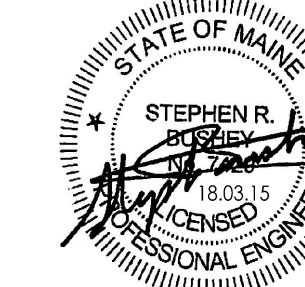

Client/Project  
ROXWIND LLC

ROXBURY WIND PROJECT

ROXBURY TOWNSHIP, MAINE

Title

MISCELLANEOUS DETAILS

Project No. 195601220	Scale AS NOTED
--------------------------	-------------------

Drawing No.	Sheet	Revision
-------------	-------	----------

C-9.0

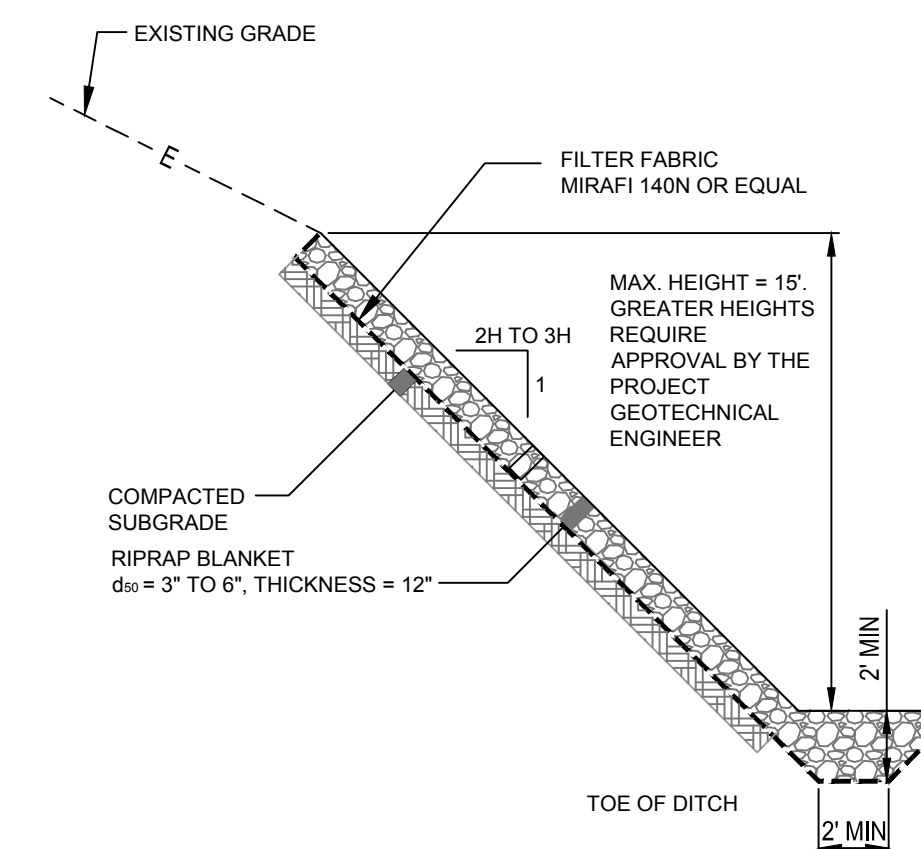

**E** STONE FACE DETAIL  
N.T.S.

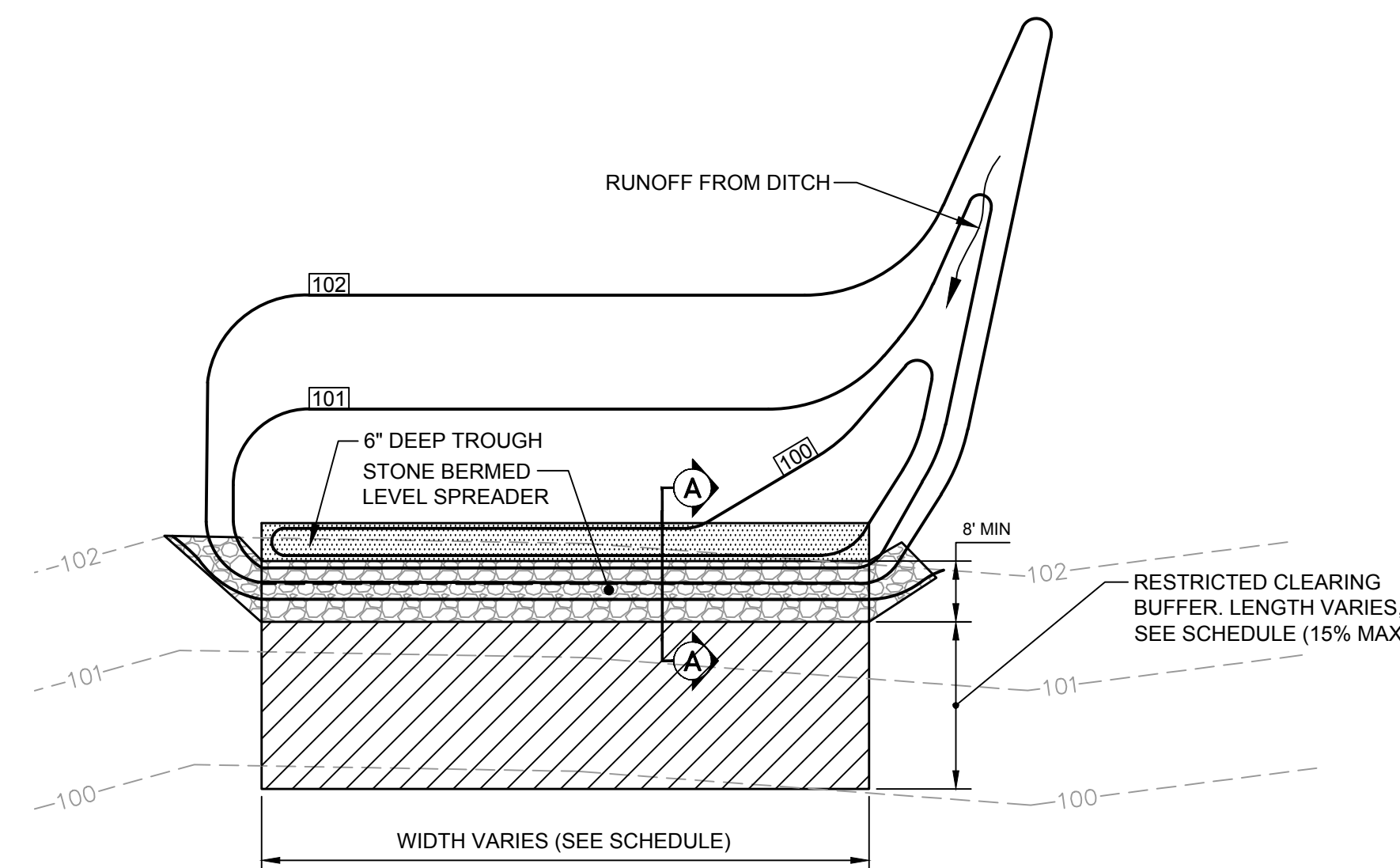

**D** STONE BERMED LEVEL SPREADER DETAIL  
N.T.S.

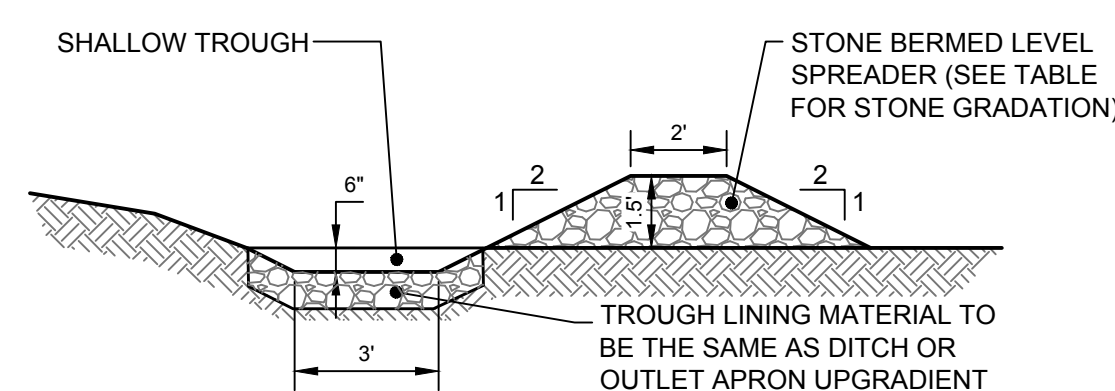

SECTION A-A

BERM STONE SIZE	
SIEVE DESIGNATION (US CUSTOMARY)	PERCENT BY WEIGHT PASSING SQUARE MESH SIEVE
12 IN	100
6 IN	84-100
3 IN	68-83
1 IN	42-55
NO. 4	8-12

NOTE:  
LEVEL SPREADER SHALL BE ORIENTATED PARALLEL TO THE EXISTING CONTOUR. SHOULD FIELD CONDITIONS CHANGE ROTATE LAYOUT OF BERM TO DIRECT SHEET FLOW ALONG EXISTING CONTOUR.

**F** VACANT  
N.T.S.

**G** VACANT  
N.T.S.

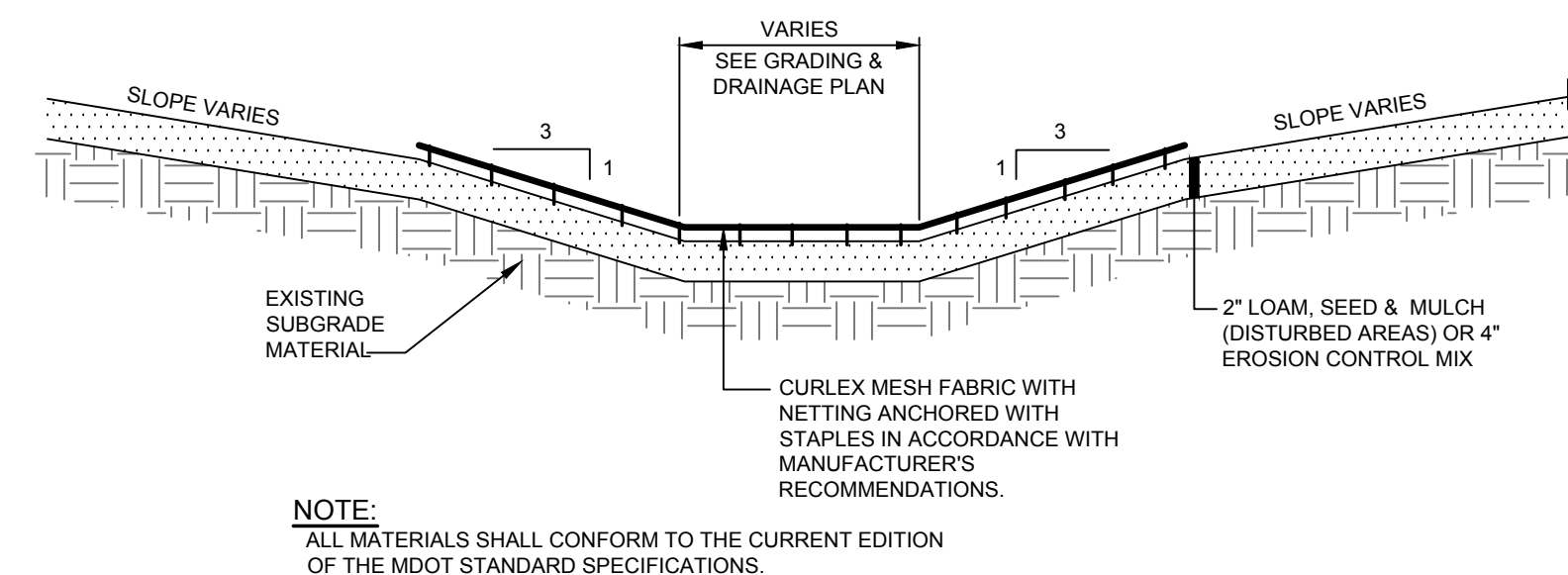

**A** VEGETATED SWALE DETAIL  
N.T.S.

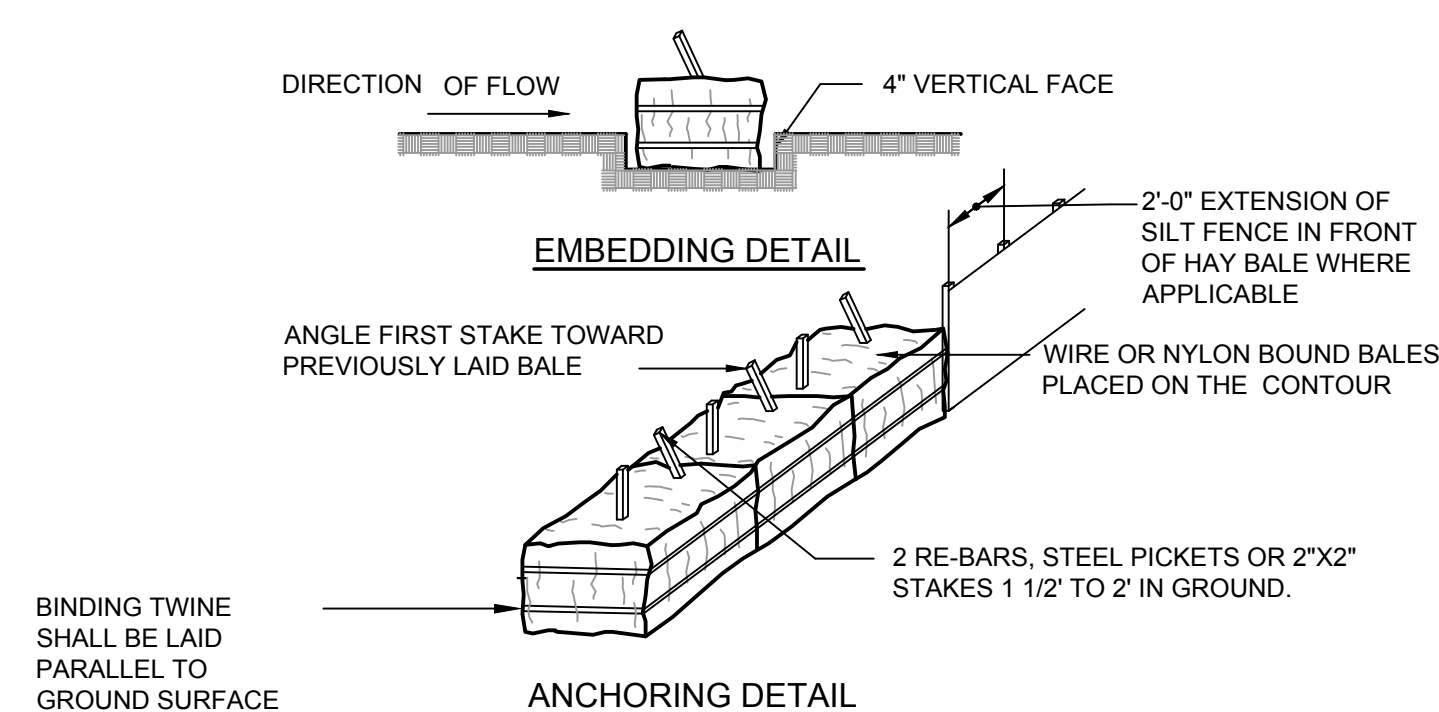

CONSTRUCTION SPECIFICATIONS

- BALES SHALL BE PLACED IN A ROW WITH ENDS TIGHTLY ABUTTING THE ADJACENT BALES.
- EACH BALE SHALL BE EMBEDDED IN THE SOIL A MINIMUM OF 4".
- BALES SHALL BE SECURELY ANCHORED IN PLACE BY STAKES OR RE-BARS DRIVEN THROUGH THE BALES. THE FIRST STAKE IN EACH BALE SHALL BE ANGLED TOWARD PREVIOUSLY LAID BALE TO FORCE BALES TOGETHER.
- INSPECTION SHALL BE FREQUENT AND REPAIR OR REPLACEMENT SHALL BE MADE PROMPTLY AS NEEDED.
- BALES SHALL BE REMOVED WHEN THEY HAVE SERVED THEIR USEFULNESS SO AS NOT TO BLOCK OR IMPEDE STORM FLOW OR DRAINAGE.

**B** STRAW OR HAY BALE BARRIER  
N.T.S.

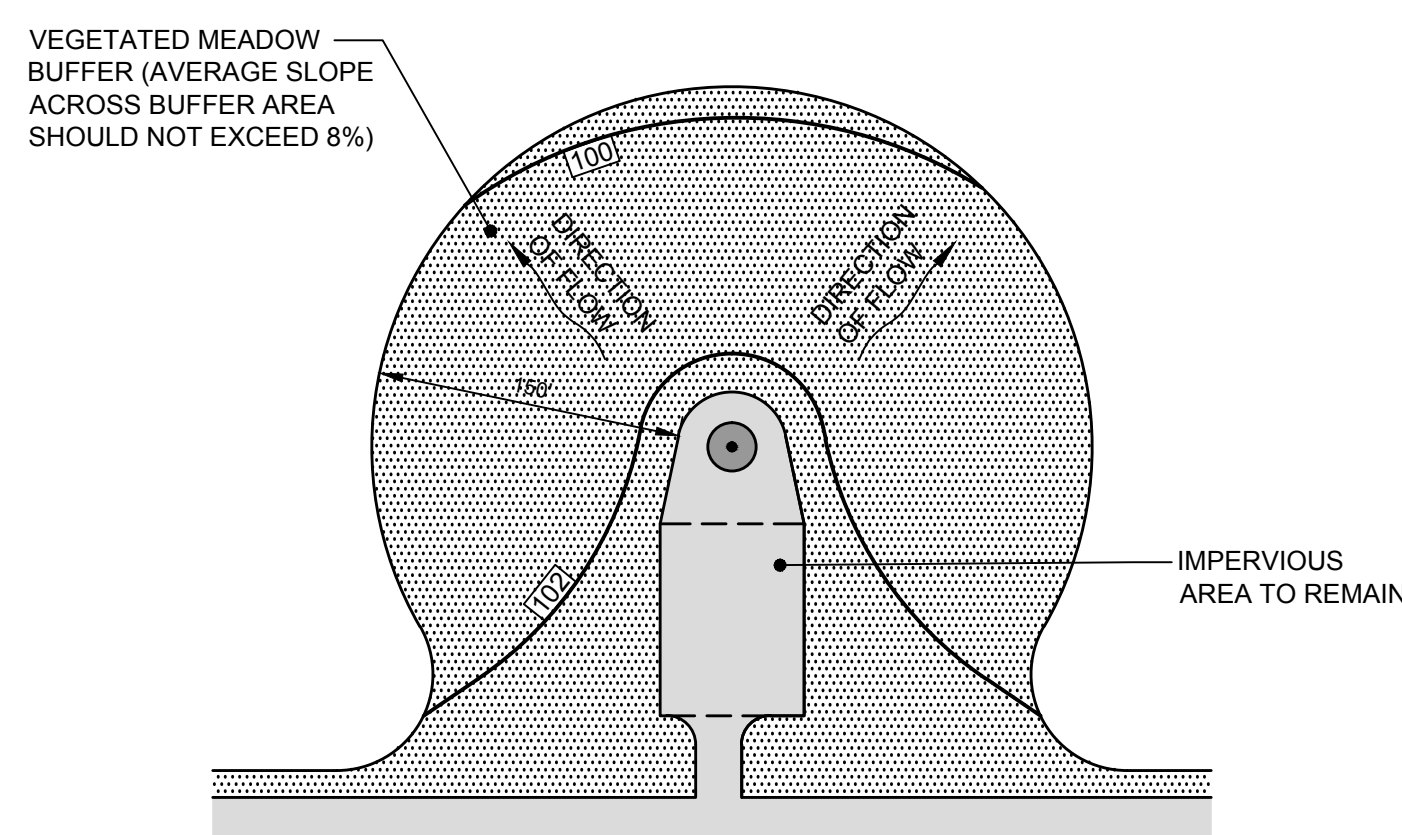

SCENARIO #1

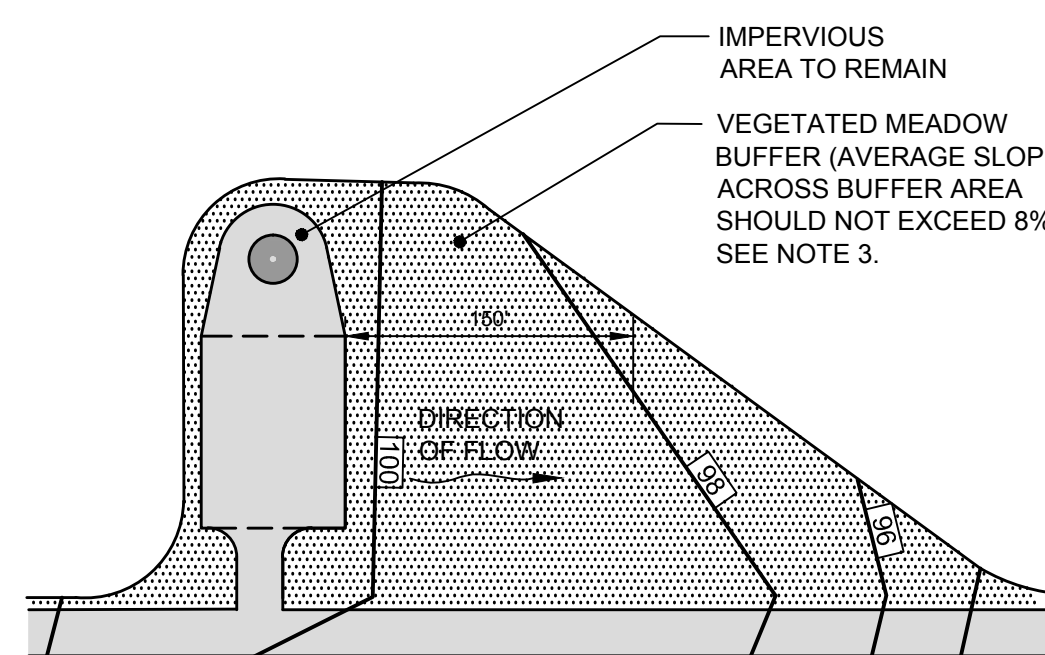

SCENARIO #2

NOTES:

- VEGETATED BUFFERS SHALL BE EITHER LOAMED AND SEEDED OR COVERED WITH EROSION CONTROL MIX AND SEEDED WITH AN APPROPRIATE SEED MIX. REFER TO DRAWING C-9.2 FOR APPROPRIATE SEED MIXES.
- SHOULD TURBINE PAD AREAS BE REDUCED DURING CONSTRUCTION, REMAINING FORESTED AREAS MAY BE COUNTED AS BUFFER AREA.

**C** TYPICAL TURBINE PAD BUFFER  
N.T.S.



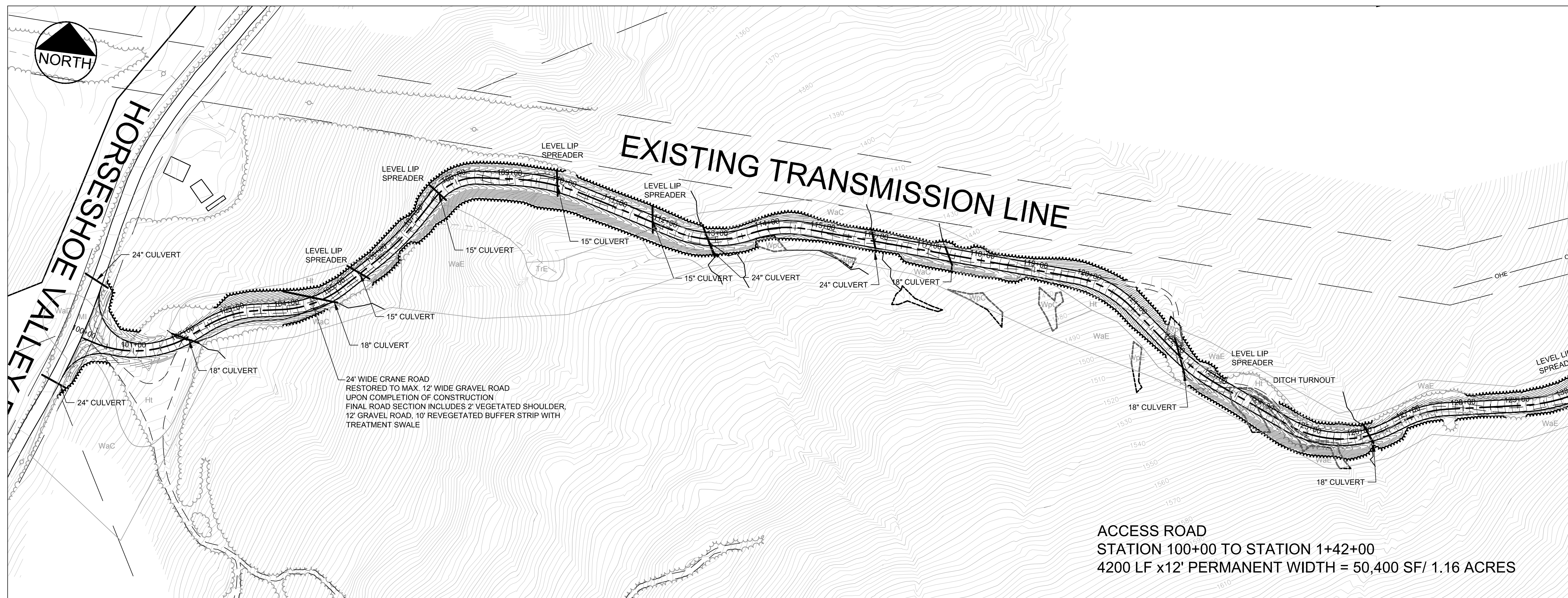

PLAN  
 SCALE: 1"=100'

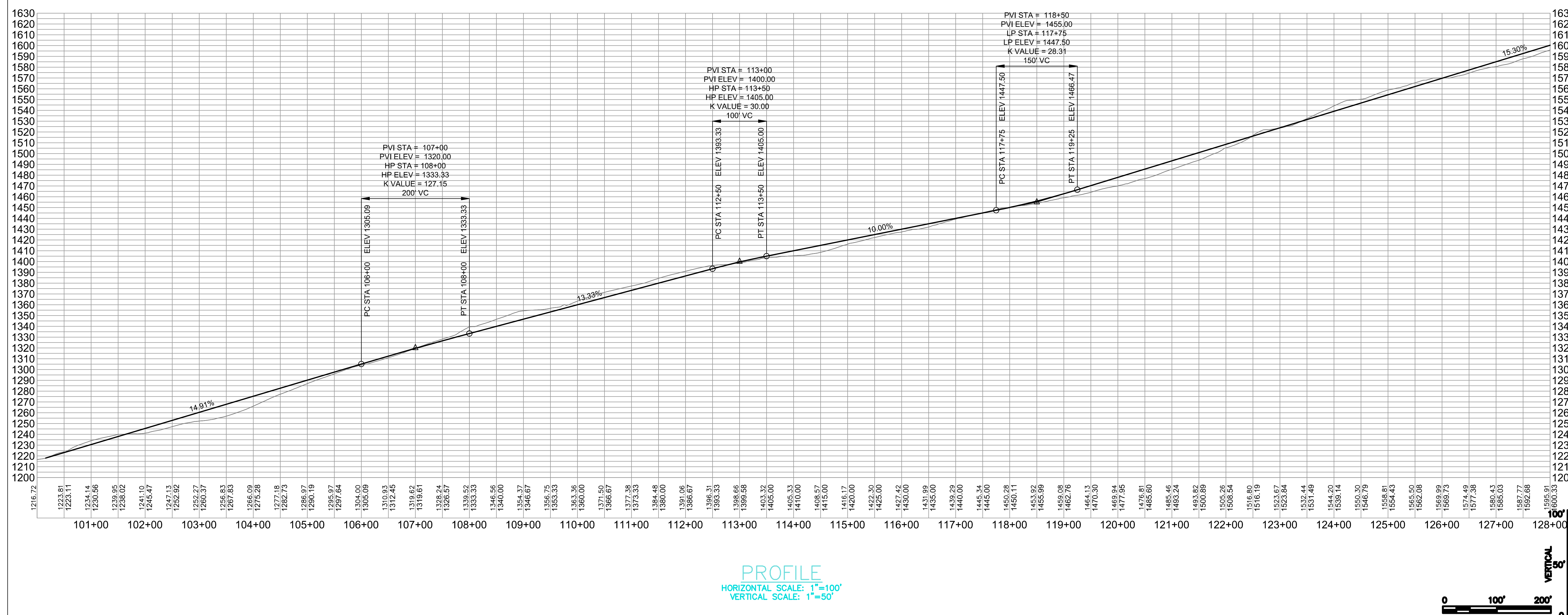

PROFILE  
 HORIZONTAL SCALE: 1"=100'  
 VERTICAL SCALE: 1"=50'

DRAFT

PERMIT DRAWINGS SUBMITTED FOR PROJECT TEAM REVIEW

Revision

Issued

File Name: P.E. STEPHEN R. BUSHEY

Permit-Seal

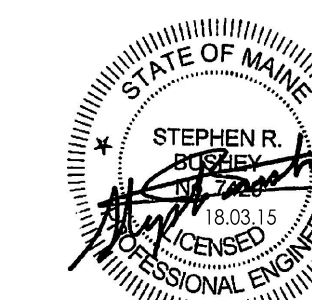

Client/Project  
 ROXWIND LLC  
 ROXBURY WIND PROJECT  
 ROXBURY TOWNSHIP, MAINE

Title  
 ACCESS ROAD PLAN AND PROFILE (STA 100+00 TO 128+00)

Project No. 195601220 Scale AS NOTED  
 Drawing No. Sheet Revision

C-N1.0



DRAFT

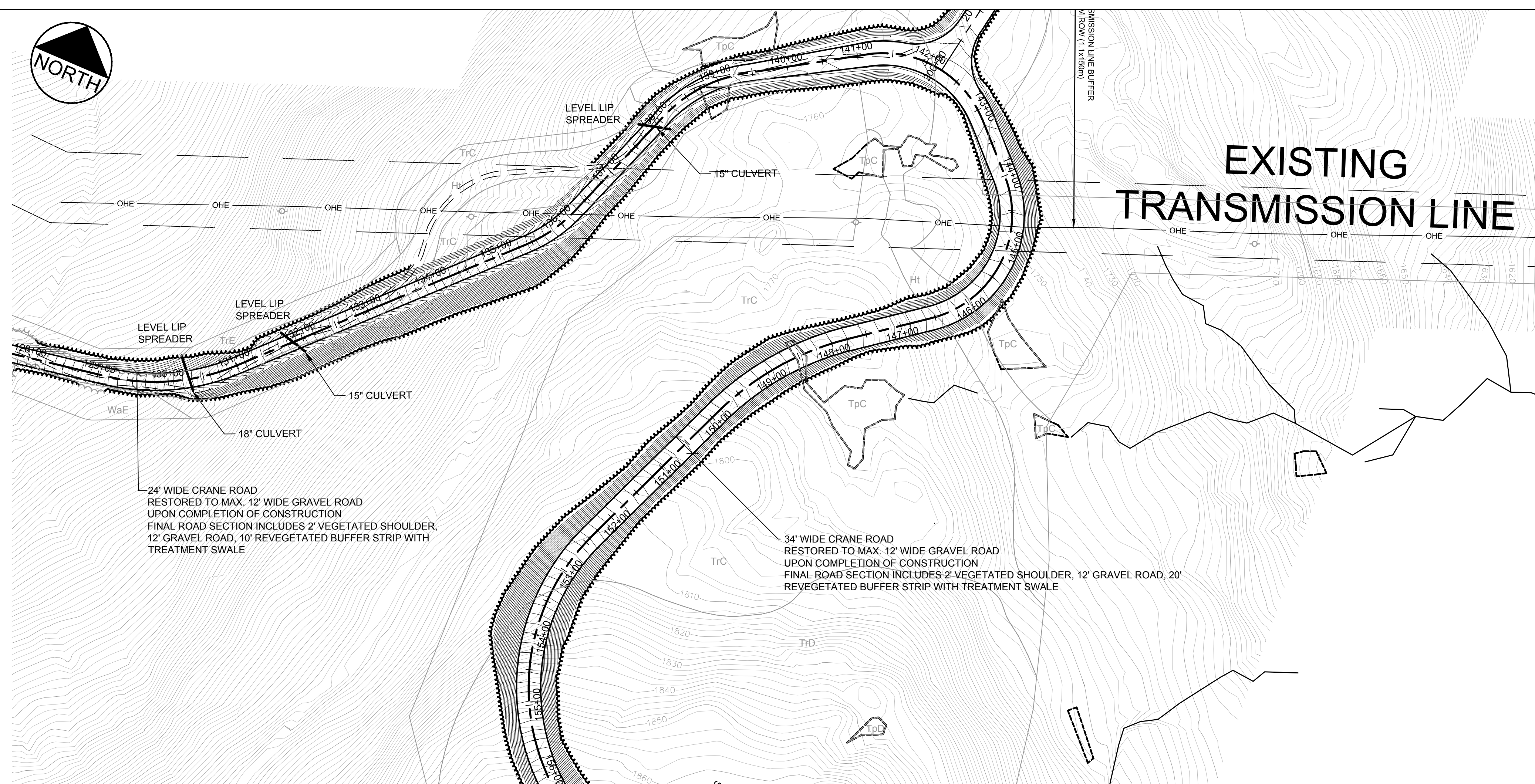

PLAN  
 SCALE: 1"=100'

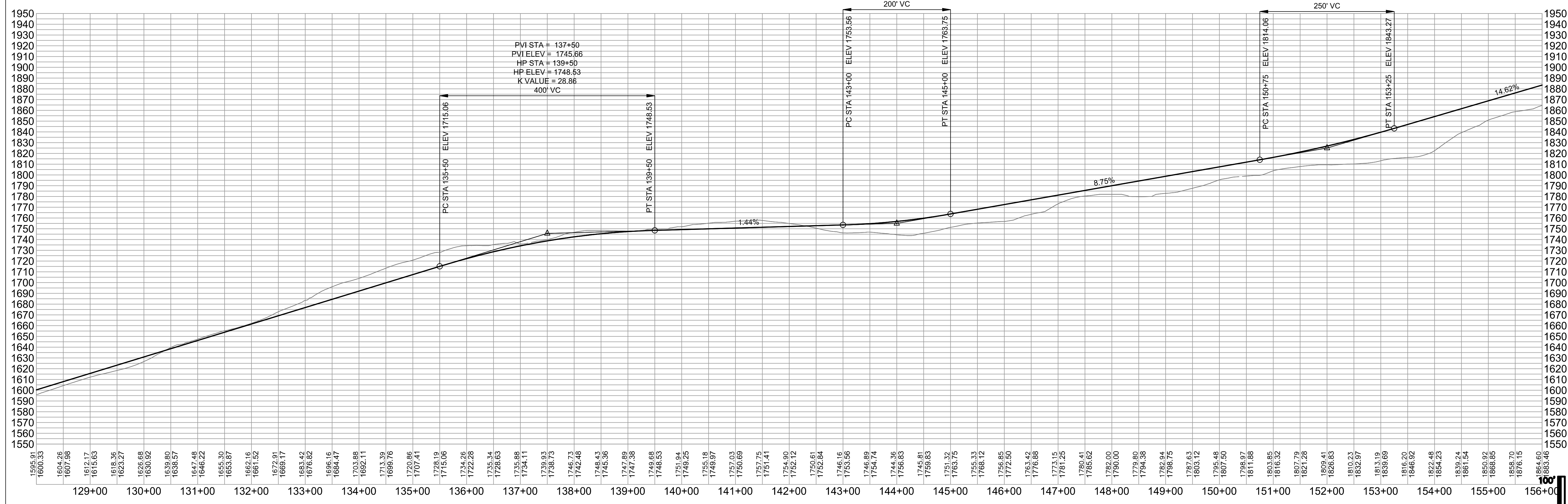

PROFILE  
 HORIZONTAL SCALE: 1"=100'  
 VERTICAL SCALE: 1"=50'

Revision	By	Appd.	YY.MM.DD
PERMIT DRAWINGS SUBMITTED FOR PROJECT TEAM REVIEW	EPL	SRB	18.03.09

Issued	By	Appd.	YY.MM.DD

File Name:	Dwn.	Chkd.	Dsgn.	YY.MM.DD
P.E. STEPHEN R. BUSHEY				

Permit-Seal

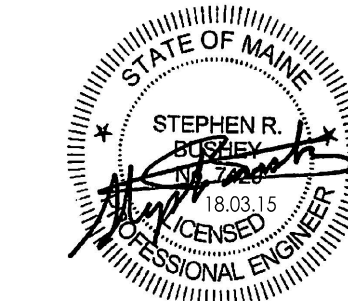

Client/Project  
 ROXWIND LLC  
 ROXBURY WIND PROJECT  
 ROXBURY TOWNSHIP, MAINE

Title  
 ACCESS ROAD PLAN AND  
 PROFILE (STA 128+00 TO 156+00)

Project No.	Scale	
195601220	AS NOTED	
Drawing No.	Sheet	Revision

C-N1.1



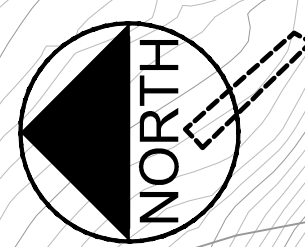

# T02

# T03

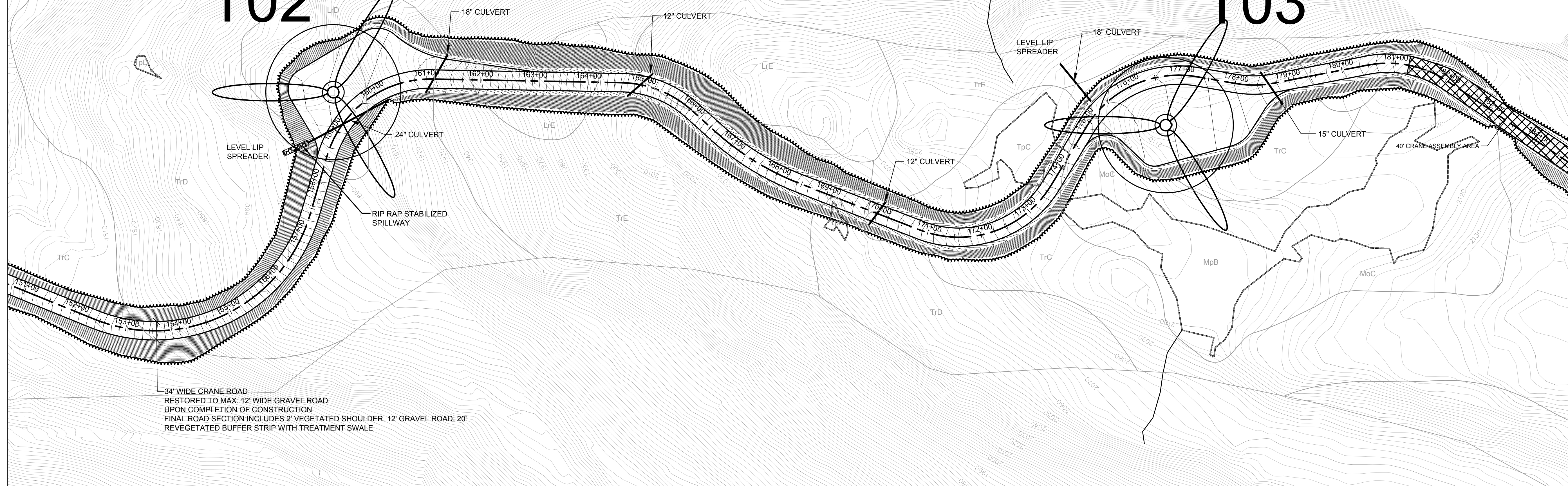

PLAN  
SCALE: 1"=100'

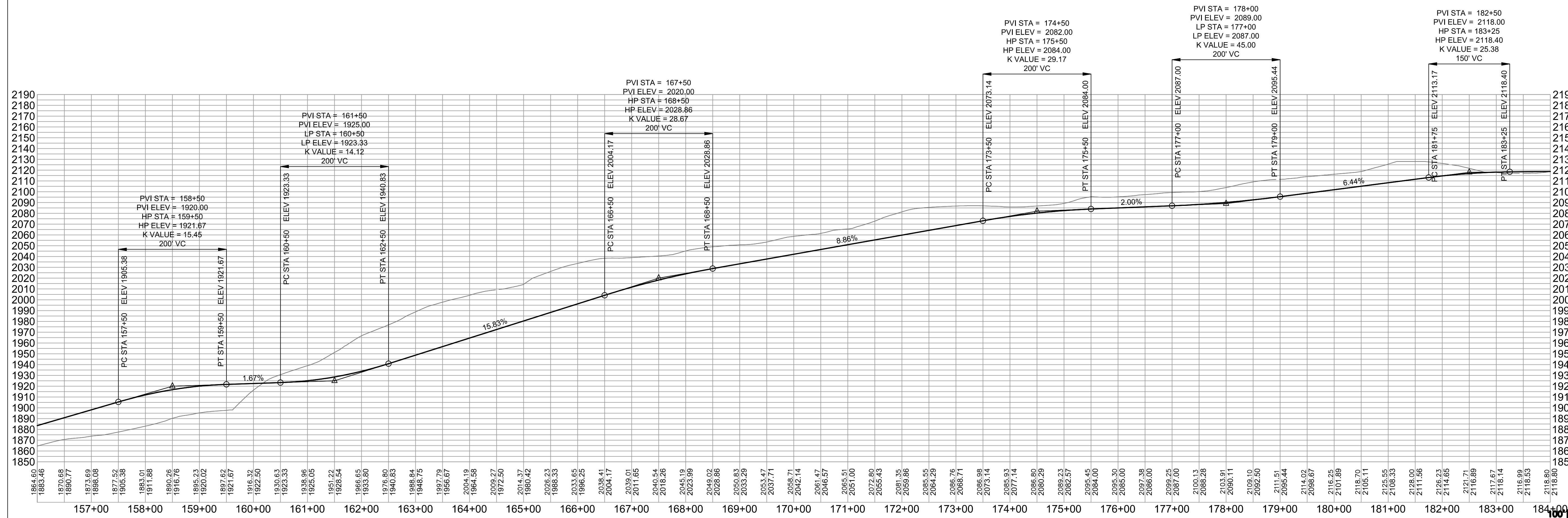

PROFILE  
HORIZONTAL SCALE: 1"=100'  
VERTICAL SCALE: 1"=50'

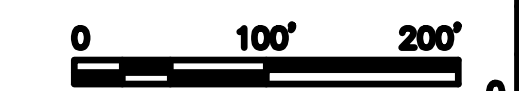

Consultants

Legend

Notes

## DRAFT

Revision	By	Appd.	YY.MM.DD
PERMIT DRAWINGS SUBMITTED FOR PROJECT TEAM REVIEW	EPL	SRB	18.03.09

Issued

File Name: P.E. STEPHEN R. BUSHEY Dwn. Chkd. Dsgn. YY.MM.DD

Permit-Seal

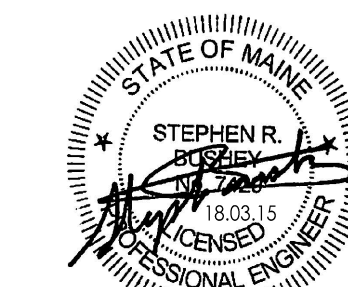

Client/Project  
ROXWIND LLC  
  
ROXBURY WIND PROJECT  
  
ROXBURY TOWNSHIP, MAINE

Title  
**CRANE ROAD PLAN AND PROFILE**  
(STA 156+00 TO 184+00)

Project No. 195601220	Scale AS NOTED
Drawing No.	Sheet Revision

C-N1.2







DRAFT

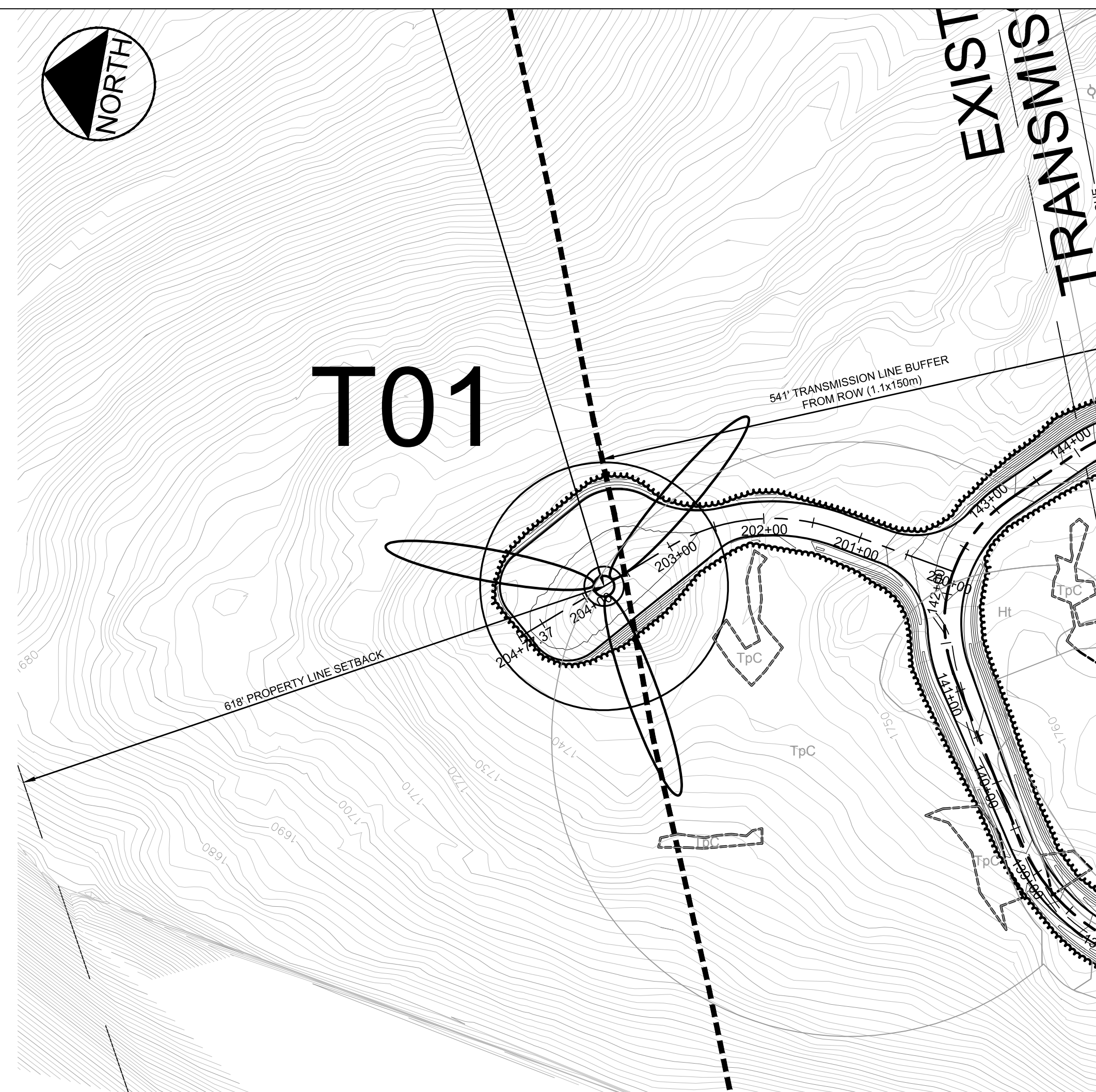

PLAN  
 SCALE: 1"=100'

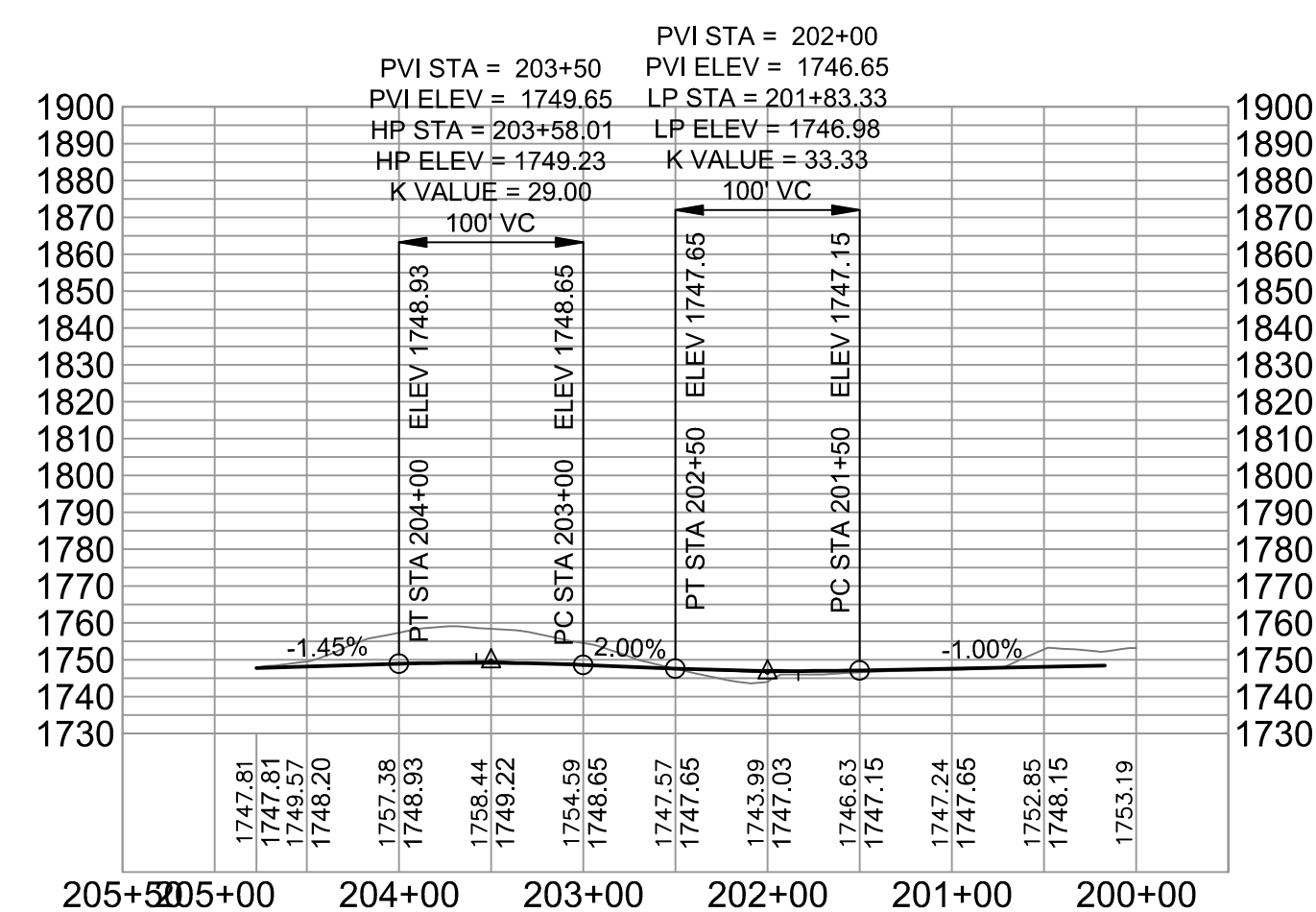

PROFILE  
 HORIZONTAL SCALE: 1"=100'  
 VERTICAL SCALE: 1"=50'

PERMIT DRAWINGS SUBMITTED FOR PROJECT TEAM REVIEW	EPL	SRB	18.03.09
Revision	By	Appd.	YY.MM.DD

Issued	By	Appd.	YY.MM.DD

File Name:	Dwn.	Chkd.	Dsgn.	YY.MM.DD
P.E. STEPHEN R. BUSHEY				

Permit-Seal

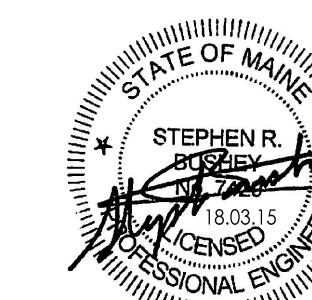

Client/Project  
 ROXWIND LLC

ROXBURY WIND PROJECT  
 ROXBURY TOWNSHIP, MAINE

Title  
 CRANE ROAD PLAN AND PROFIL  
 (STA 200+00 TO 204+77)

Project No.	Scale	
195601220	AS NOTED	
Drawing No.	Sheet	Revision

C-N1.4

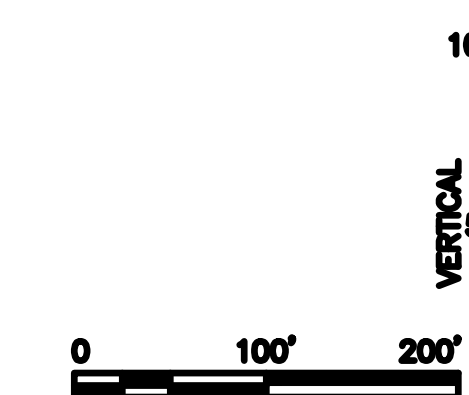

**STORMWATER MANAGEMENT  
NARRATIVE  
(framework taken from Section  
12 of SLODA application  
checklist)**

Roxbury Wind Project



Submitted to:  
Maine Department of  
Environmental Protection

Submitted by:  
RoxWind LLC

Prepared by:  
Stantec Consulting Services Inc.  
482 Payne Road  
Scarborough, ME 04074

March 20, 2018

**STORMWATER MANAGEMENT NARRATIVE  
(FRAMEWORK TAKEN FROM SECTION 12 OF SLODA APPLICATION CHECKLIST)**

**Table of Contents**

12.1 WIND POWER PROJECT SUMMARY..... 1

12.2 SURFACE WATER ON OR ABUTTING THE SITE..... 1

12.3 DOWNSTREAM PONDS AND LAKES ..... 1

12.4 GENERAL TOPOGRAPHY ..... 2

12.5 FLOODING..... 2

12.6 ALTERATIONS TO NATURAL DRAINAGE WAYS ..... 2

12.7 ALTERATIONS TO LAND COVER WITHIN THE WATERSHED ..... 3

12.8 MODELING ASSUMPTIONS ..... 3

12.9 MAPS..... 4

12.10 DRAINAGE PLANS ..... 4

12.11 RUNOFF ANALYSIS ..... 5

12.12 PEAK RUNOFF COMPUTATIONS ..... 5

12.13 VARIANCE SUBMISSIONS ..... 6

12.14 SIZING OF CULVERTS ..... 6

12.15 STORMWATER TREATMENT ..... 6

12.16 INFILTRATION SYSTEM ..... 7

12.17 DRAINAGE EASEMENT DECLARATIONS..... 7

12.18 STORMWATER QUALITY TREATMENT PLAN..... 7

12.19 OFF-SITE CREDITS ..... 8

12.20 RUNOFF TREATMENT MEASURES..... 8

12.21 CONTROL PLAN FOR THERMAL IMPACTS TO COLDWATER FISHERIES ..... 9

12.22 CONTROL PLAN FOR OTHER POLLUTANTS..... 9

**STORMWATER MANAGEMENT NARRATIVE  
(FRAMEWORK TAKEN FROM SECTION 12 OF SLODA APPLICATION CHECKLIST)**

**12.23 ENGINEERING INSPECTION OF STORMWATER MANAGEMENT FACILITIES ..... 9**

**12.24 COMPONENTS OF THE ROXBURY WIND PROJECT POST-CONSTRUCTION  
STORMWATER MAINTENANCE PLAN ..... 9**

**LIST OF APPENDICES**

**APPENDIX A POST CONSTRUCTION STORMWATER INSPECTION AND MAINTENANCE  
LOG ..... A.1**



**STORMWATER MANAGEMENT NARRATIVE  
(FRAMEWORK TAKEN FROM SECTION 12 OF SLODA APPLICATION CHECKLIST)**

Wind Power Project Summary

March 20, 2018

## **12.1 Wind Power Project Summary**

RoxWind LLC (Applicant) is proposing a small-scale wind energy project in the Town of Roxbury, Maine: the Roxbury Wind Project (project). The project consists of 4 wind turbine generators, underground and overhead collection lines, and approximately 1.7 miles of access and crane roads. The project area consists of roads and turbine sites on the North Twin Mountain ridge just south of Route 120 in Roxbury. The site will be accessed from Horseshoe Valley Road. The project area is identified within the D-5 area of Map 18 of the DeLorme Gazetteer.

The project area consists of undeveloped forestland that has been heavily logged. An existing logging road traverses the west side of the hill and logging equipment trails are located throughout most of the top of the ridge and along the hillside. Approximately 6.3 acres of impervious area in the form of roads and turbine pads will be created during construction. Following construction, approximately 3.5 acres of the constructed impervious area will be permanently revegetated. Approximately 2.8 acres will remain as new impervious area and will consist of approximately 9,000 LF of 12-foot-wide gravel maintenance road and remaining crane pads at each of the 4 turbine sites. The overall project footprint related to the roads and pad areas will amount to approximately 16.9 acres. The transmission line corridor will “occupy” another 0–1.5 acres. The total project area is estimated to be approximately 16.9–18.4 acres.

The following narrative describes and quantifies pre- and post-development stormwater characteristics of the project area. The accompanying discussion demonstrates that construction of the project will comply with the applicable Maine Department of Environmental (MeDEP) Stormwater Management Requirements in Chapter 500. The stormwater management measures for this development have been designed to meet the applicable Basic Standards, General Standards, and Flooding Standards of Chapter 500.

## **12.2 Surface Water on or Abutting the Site**

The development activities are located along the North Twin ridge top and hill side. The west side of the hill drains to Meadow Brook and ultimately the Ellis River, which flows to the Androscoggin River. The east side of the hill drains to the Swift River and ultimately the Androscoggin River. There are no known watershed resources of concern or impaired within the immediate downstream area of the site.

## **12.3 Downstream Ponds and Lakes**

The project is not within a lake or pond watershed.

**STORMWATER MANAGEMENT NARRATIVE  
(FRAMEWORK TAKEN FROM SECTION 12 OF SLODA APPLICATION CHECKLIST)**

General Topography

March 20, 2018

## **12.4 General Topography**

The topography of the land surface within the project area is mountainous terrain, as is common within this portion of the state. Along the ridge top, slopes range from approximately 5 to 25 percent. Elevations across the area range from approximately 1,200 feet above mean sea level at the base of the hill to 2,150 feet above mean sea level along the ridgeline. Two-foot aerial contour mapping has been used for the basis of design and analysis. Various existing drainage flow paths have been identified within the project limits as part of soils data collection and natural resources data collection.

## **12.5 Flooding**

Stantec has not reviewed in detail the 100-year flood zone mapping for Roxbury Township; however, based on inspection, no portion of the proposed project is expected to lie within any mapped floodplain.

## **12.6 Alterations to Natural Drainage Ways**

In the post-development condition, the existing drainage patterns will be maintained to the extent practicable by implementing stormwater management practices that mimic existing hydrology. The proposed access and ridgeline crane roads will be constructed to a width of 24 feet and 34 feet, respectively, during the construction period. Following construction, these roads will be permanently restored to a narrow width of 12 feet to provide a maintenance road access. The remaining construction road sections will be restored to a vegetated cover condition and also contain a shallow treatment swale running the length of the roads. The treatment swale is proposed as the primary method for water quality treatment. Forested buffers<sup>1</sup> were considered; however, because the buffers must be included in the calculation of the “occupied” project area, it was determined that an alternative form of treatment Best Management Practice (BMP), to be located within the road area, is necessary to reduce the overall project area to below the 20-acre permitting threshold. To keep the natural hillside drainage patterns intact to the extent practicable, the stormwater management design will also consist of incorporating numerous culverts, ditch turnouts, level spreaders, and plunge pools spaced where appropriate along the access and crane roads to collect runoff and then discharge to return the runoff to sheet flow or to otherwise maintain current hydrologic

---

<sup>1</sup> See Maine Department of Environmental Protection Volume III BMP Technical Design Manual – Chapter 5

## **STORMWATER MANAGEMENT NARRATIVE (FRAMEWORK TAKEN FROM SECTION 12 OF SLODA APPLICATION CHECKLIST)**

Alterations to Land Cover Within the Watershed

March 20, 2018

conditions. The project construction may also include the use of rock sandwich road sections that will effectively allow shallow subsurface flow to pass horizontally through roadway material to maintain the natural hydrologic conditions; however, the use of the rock sandwich section is likely to be limited.

### **12.7 Alterations to Land Cover Within the Watershed**

Following construction, approximately 3.5 acres of the 6.3 acres of impervious area temporarily created for gravel construction surfaces will be restored to permanent vegetative cover, resulting in approximately 2.8 acres of new, permanent impervious areas (12-foot-wide gravel roads, wind turbine foundations, and crane pads).

The following is a description of each development activity proposed:

1. **Wind Turbine Pads:** Each wind turbine pad will be constructed within cleared site limits of approximately 1 to 2 acres. The pad sites will contain a 25-foot-diameter concrete turbine foundation pedestal with a 16-foot-wide gravel ring surrounding the pedestal, a 75-foot by 35-foot permanent gravel crane pad, and 12-foot access drives into the pad area off the wind farm access road. Most of the construction area will be restored with erosion control mix and seeding with only the foundation pedestal, gravel ring, gravel crane pad, and access drives remaining as impervious area.
2. **Access and Crane Roads:** The project will include approximately 1.7 miles of access road (generally following an existing 10-foot-wide logging road) and new ridgeline crane road. During construction, the hillside access road will be constructed to a 24-foot-wide gravel surface for the passage of turbine equipment delivery vehicles and construction traffic. The crane road will be located along the ridge top and will be constructed as a 34-foot wide temporary gravel surface. Excepting for a short length of road that will be constructed at 40 feet wide to allow for crane assembly, the roads will be revegetated to a permanent width of 12 feet post-construction. The restoration of the crane road is expected to include a minimum 10-foot-wide to 20-foot-wide vegetative restoration strip and treatment swale on the downhill side of the permanent road, within the original 24- or 34-foot-wide area (i.e., the permanent road section includes a 2-foot-wide vegetated shoulder on the uphill side, 12-foot-wide gravel maintenance road, and 20-foot-wide vegetated level buffer edge and treatment swale on the downhill side)

### **12.8 Modeling Assumptions**

Our experience on previously permitted and constructed wind farms is that MeDEP has agreed that stormwater runoff modeling to determine pre- and post-development peak flows under the

## **STORMWATER MANAGEMENT NARRATIVE (FRAMEWORK TAKEN FROM SECTION 12 OF SLODA APPLICATION CHECKLIST)**

Maps

March 20, 2018

flooding standards is not strictly required for wind farm projects that do not contain an Operations and Maintenance (O&M) building site, dynamic reactive device (DRD), and substation area(s), as is the case with this project. Instead, a brief pre- and post-development curve number (CN) comparison analysis is substituted as evidence that the project will have an insignificant impact on the peak stormwater flows in the watershed. For this project, the overall change to CN for the watersheds is based on soils and vegetative cover.

Generally, the site soils are predominantly Hydrologic Soils Group (HSG) D soils, with limited HSG B and C soils. The ridgeline contains predominantly D soils and the lower sections of the hillside contain B and C soils.<sup>2</sup> The introduction of a small area of impervious area within the broader watershed will result in an insignificant impact to the overall CN coefficient for the watersheds. Thus, there is expected to be no measurable impact to peak discharge attributable to the project. This finding is consistent with other wind farm proposals previously reviewed and approved by MeDEP.

### **12.9 Maps**

Mapping used for this stormwater analysis is summarized below:

- Watershed worksheets on file with the Stantec engineer.
- Soils mapping obtained from the Natural Resources Conservation Service (NRCS) Soil Survey of Oxford County, Maine.
- Soils mapping developed from the Class L Soil Survey completed by Stantec for the areas affected by project construction.

### **12.10 Drainage Plans**

Stantec has prepared the preliminary road and crane pad plans for the proposed development area. The progress plans currently include existing and proposed topography and clearing limits. Additional information including general cover types, soil groups, watershed boundaries, existing features, primary drainage ways, locations of proposed turbine pads and new roads are also identified on the plans.

---

<sup>2</sup> See Class L soils survey results from Stantec.



**STORMWATER MANAGEMENT NARRATIVE  
(FRAMEWORK TAKEN FROM SECTION 12 OF SLODA APPLICATION CHECKLIST)**

Runoff Analysis

March 20, 2018

## **12.11 Runoff Analysis**

A specific pre- and post-development analysis of peak flows has not been performed due to the overall project area size; instead a CN comparison analysis supports the finding that there will be no significant impact to runoff peak flows resulting from the project. The analysis includes a brief computation for determining the increase of runoff CN values for the pre- and post-development project watersheds. A runoff CN of 55 to 77 can be used for the pre-development watershed based on HSG B soils and HSG D soils for a Woods condition<sup>3</sup>. The purpose of the CN analysis is to show that the proposed project activities result in an insignificant impact to the overall watershed CN. A watershed CN is an indicator for predicting direct runoff or infiltration from rainfall excess. A significant change (increase) in the CN might indicate an increase in stormwater runoff conditions. An insignificant change in the CN indicates there will be no impact to overall stormwater runoff conditions. A summary of the pre- and post-development CN values is provided in the following Section.

## **12.12 Peak Runoff Computations**

### **A. Curve Number Computation for Linear Portions of Project**

The soils and HSGs within the project area are based on the Class L Soil Survey completed by Stantec. Soils are generally HSG B, C, and D within the study area. For assessing the overall CN of the watershed, the engineer assumed a study area that extends 750 feet to each side of the project limits. This amounts to an area exceeding 300 acres. Based on the approximate watershed area an average predevelopment CN value of about 70. In the post-development condition, the minor increase of 2.8 acres of gravel surface with CN of 88 (avg.) results in an insignificant impact to the overall CN for the 300-acre area.

The weighted CN for the post development watershed changes insignificantly (< 0.5%) from the pre-developed condition to the post-developed condition since there is an insignificant change to the overall impervious cover types, i.e., 2.7 acres is less than 1% of the total study area for this analysis. On this basis, we can conclude that the impact due to the creation of the impervious areas by this development and its small change in land cover in relation to the overall size of the watersheds is negligible. This finding is consistent with many other larger wind projects, which have contained far more road or turbine pads and less permanent vegetative restoration.

---

<sup>3</sup> See USDA Technical Release 55 (TR-55) Chapter 2 Table 2-2c

**STORMWATER MANAGEMENT NARRATIVE  
(FRAMEWORK TAKEN FROM SECTION 12 OF SLODA APPLICATION CHECKLIST)**

Variance Submissions

March 20, 2018

## **12.13 Variance Submissions**

A variance from the peak flow standard is not necessary for the linear portions of the project. As stated previously, due to the small amount of impervious area created relative to watershed size, the CN analysis has demonstrated that there will be no significant impact to post-development runoff conditions. As a result, the project will not adversely affect downstream conveyance conditions or properties.

## **12.14 Sizing of Culverts**

All culvert sizing and placement has been based on the MeDEP Chapter 500.5.A Standards. These standards require that all projects discharging runoff in the form of concentrated flow must convert the runoff to sheet flow before leaving the project limits unless within an existing concentrated flow pattern or conveyance channel. To achieve this objective, flared ends and rip rap outlet aprons and level spreaders are detailed on the plans at locations where sheet flow dispersal is desired. The calculations for sizing the proposed culverts are underway and will be provided upon completion by the engineer. Detailed drawings for the proposed on-site conveyance structures, including drainage swales, culverts with inlet and outlet protection, and ditch turnouts, are shown on the Plan and Profile Drawings and Construction and Erosion Control Detail drawings in the Permit Plan Set. Stabilization methods will be designed, constructed, and maintained in accordance with the project's Erosion and Sedimentation Control Plan (E&S Plan), which is consistent with the *Maine Erosion and Sedimentation Control Best Management Practices*.

Please refer to the erosion control notes sheet for a detailed description of the site-specific erosion control measures and practices to be utilized during construction of the access road, crane road, pads, and collector system.

## **12.15 Stormwater Treatment**

Generally, water quality treatment will be provided by vegetated swales and permanent restoration of a vegetated edge along the length of the access and crane roads. The restored vegetated edge will extend 10 feet on the access road and 20 feet on the crane road. Runoff generated by the remaining 12-foot-wide maintenance road will sheet across the revegetated strip and collect in the treatment swale. The treatment swale will contain an 18-inch-deep filter media layer, as is customary for a filtering BMP. This treatment approach varies from the traditional use of undisturbed roadside buffers, ditch turnout buffers and level lip spreader buffers as it is necessary to maintain the overall project "occupied" area to less than 20 acres. The use

**STORMWATER MANAGEMENT NARRATIVE  
(FRAMEWORK TAKEN FROM SECTION 12 OF SLODA APPLICATION CHECKLIST)**

Infiltration System

March 20, 2018

of undisturbed buffers would require a project area greater than 3 acres, which would then trigger an overall project area that “occupies” in excess of 20 acres.

## **12.16 Infiltration System**

No formal infiltration systems are proposed. Because the proposed roads will be constructed largely from blasted rock fill, the design does not incorporate any underdrain pipe installation beneath the vegetated treatment swales. The absorption of runoff in the swales will result largely in water passing through the filter media, into the subbase conditions, where water is expected then to move laterally out through the blasted rock fill road section, with breakout at the toe of slope or into the roadside ditches for conveyance to culverts, turnouts, level spreaders, and plunge pools.

## **12.17 Drainage Easement Declarations**

No formal drainage easements are required as the use of buffers for water quality treatment is not proposed.

## **12.18 Stormwater Quality Treatment Plan**

The project lies within watersheds that directly contribute to river segments. Water quality has been evaluated for Basic Standards and General Standards.

### **A. Basic Standards Submissions**

In accordance with the Basic Standards, stormwater conveyance structures will be designed, constructed, and stabilized using Erosion and Sedimentation (E&S) BMPs. The stormwater conveyance structures will be maintained to prevent or correct any noted erosion problems to ensure their continued effectiveness. The Applicant's E&S Plan outlines the measures that will be utilized to prevent erosion from occurring, and to address any problems that may develop. The E&S Plan incorporates the applicable methods and materials presented in the *Maine Erosion and Sediment Control BMPs*, dated March 2003. The E&S Plan contains the details and specifications for general stabilization of the site. These measures will be used to protect exposed soils during construction and during the service life of the project. The primary erosion control

## **STORMWATER MANAGEMENT NARRATIVE (FRAMEWORK TAKEN FROM SECTION 12 OF SLODA APPLICATION CHECKLIST)**

Off-Site Credits

March 20, 2018

measure to be used during construction will be the use of Erosion Control Mix<sup>4</sup> that will be placed over much of the project's disturbed surfaces. The use of Erosion Control Mix has been found to be most effective for the type of soil disturbance activity proposed.

The stabilization measures for the site will include temporary and permanent E&S controls; appropriate design of swales, culverts, and erosion protection for earthen cut and fill slopes; and provisions for future maintenance of the site.

### **B. General Standards Submission**

The proposed development will have more than 1 acre of impervious area and will have more than 5 acres of developed area so compliance with the General Standards is required at a minimum. The development activity generally consists of roads that are considered linear. The standards for linear projects require that at least 75 percent of the impervious area within the project be treated. To achieve the water quality treatment goal, the project will employ a strategy including the restoration of a vegetated edge along the access and crane roads. This vegetated edge will also contain a linear treatment swale with filter media bottom. The intent is for runoff from the 12-foot-wide maintenance road to sheet across the vegetated surface and to be collected in the treatment swale. The 4 turbine pads will also contain vegetative surface restoration where any runoff emanating from the remaining pad, turbine foundation and access road will sheet across a restored meadow condition covering the pad site.

## **12.19 Off-Site Credits**

Off-site credits for total suspended solids (TSS) or phosphorous are not proposed for the project.

## **12.20 Runoff Treatment Measures**

The drainage design for this project will consist of revegetated roadside edges promoting sheet flow, vegetated treatment swales, vegetated and stone-lined conveyance swales, culverts, ditch turnouts, level spreaders, and plunge pools. Vegetated and stone-lined swales within earthwork cut sections will collect and direct runoff from a portion of the access road, crane road, turbine pads. The swales may discharge to level spreaders and/or plunge pools to convert shallow concentrated flows to sheet flow prior to the runoff leaving the project area.

---

<sup>4</sup> See Maine Department of Environmental Protection – Information Sheet: Erosion Control Mix for Mulch – [www.maine.gov/dep/blwq/docstand/stormwater/is-ecmixmulch.htm](http://www.maine.gov/dep/blwq/docstand/stormwater/is-ecmixmulch.htm)

**STORMWATER MANAGEMENT NARRATIVE  
(FRAMEWORK TAKEN FROM SECTION 12 OF SLODA APPLICATION CHECKLIST)**

Control Plan for Thermal Impacts to Coldwater Fisheries

March 20, 2018

## **12.21 Control Plan for Thermal Impacts to Coldwater Fisheries**

The development activities will not result in thermal impact to downstream conditions based on the insignificant impact to overall runoff conditions in the watersheds. The use of level spreaders and turnouts to disperse concentrated flow into wooded areas will also prevent thermal impacts.

## **12.22 Control Plan for Other Pollutants**

A control plan for other pollutants in stormwater runoff is not required.

## **12.23 Engineering Inspection of Stormwater Management Facilities**

The Applicant will ensure that a professional engineer or qualified representative inspects the construction site periodically to verify that the stormwater culverts, conveyance swales, level spreaders, and plunge pools are constructed in accordance with the plans and specifications shown on the permit plan set and that these structures are functioning properly. These inspections will commence with the initial earth moving activities on the site and will continue, as needed, during any period when construction activity affecting the stormwater management system occurs, until the site is permanently stabilized.

## **12.24 Components of the Roxbury Wind Project Post-Construction Stormwater Maintenance Plan**

The project will be solely-owned, operated, and maintained by RoxWind LLC.

### **A. Stormwater Management Measures to be Inspected and Maintained**

The stormwater management facilities to be maintained at the project site may include:

- Vegetated roadside edges;
- Vegetated stormwater conveyance swales;
- Ditch turn-outs, level spreaders, and plunge pools;

## **STORMWATER MANAGEMENT NARRATIVE (FRAMEWORK TAKEN FROM SECTION 12 OF SLODA APPLICATION CHECKLIST)**

Components of the Roxbury Wind Project Post-Construction Stormwater Maintenance Plan

March 20, 2018

- Culverts with inlet/outlet protection;
- Permanent maintenance road; and
- Revegetated areas and embankments.

### **B. General Inspection and Maintenance Requirements**

Generally, the proposed facility will be operated and maintained in a manner consistent with good utility practices, including quarterly visual inspections (from March through November or as directed below) and routine maintenance of stormwater management structures as needed.

Visual inspection and maintenance requirements for these facilities are identified below.

#### **1. Vegetated Stormwater Conveyance Swales:**

Visually inspect for any signs of existing or developing blockage of flow, trash, erosion, channeling, or excessive build-up of sediment. Vegetated swales/ditches will be mowed or otherwise maintained to control the growth of woody vegetation within the channel but no more than once per year. Rip rap swales/ditches will be visually inspected for signs of scour beneath rip rap or dislodging of any stones.

#### **2. Ditch Turn-outs, Level Spreaders, and Plunge Pools:**

Visually inspect semi-annually and following major storm events for the first year for signs of channelization. Repairs will be made immediately. After first year inspect annually for signs of channelization and debris/sand build-up. Debris will be removed as needed.

#### **3. Culverts with Inlet/Outlet Protection:**

Visually inspect culverts for signs of blockage at inlet and outlet. Remove any debris that is creating blockage as needed.

#### **4. Permanent Maintenance Road:**

The roadway will typically require little on-going maintenance due to the limited use of heavy vehicles although routine ATV and related traffic may result in erosive conditions. These areas will be visually inspected quarterly, and signs of existing or developing areas of channelized flow, erosion, rutting, trash, or unwanted vegetation will be removed/repared as needed.

#### **5. Revegetated Areas and Embankments:**

Revegetated areas and embankments will be inspected monthly. Any signs of erosion or inadequate revegetation of these areas will be corrected as needed. Re-seed and mulch any areas with less than 90% cover.



# **APPENDICES**

**STORMWATER MANAGEMENT NARRATIVE  
(FRAMEWORK TAKEN FROM SECTION 12 OF SLODA APPLICATION CHECKLIST)**

Appendix A Post Construction Stormwater Inspection and Maintenance Log

March 20, 2018

**Appendix A Post Construction Stormwater Inspection and  
Maintenance Log**



**STORMWATER MANAGEMENT NARRATIVE  
(FRAMEWORK TAKEN FROM SECTION 12 OF SLODA APPLICATION CHECKLIST)**

Appendix A Post Construction Stormwater Inspection and Maintenance Log

March 20, 2018

Roxbury Wind Project				
Stormwater Management System Inspection & Maintenance Log				
	Schedule			
	As-needed Inspection	Maintenance	Inspector Initials and Date	Inspector Comments
Revegetated Areas and Embankments:				
Inspect all revegetated areas and embankments	X			
Replant bare areas or areas with sparse growth		As Required		
Armor areas with rill erosion with an appropriate lining or divert the erosive flows to on-site		As Required		
Drainage Conveyance Systems:				
Inspect swales, level spreaders and plunge pools for evidence of erosion, debris, woody growth, and excessive sediment	X			
Remove any obstructions and accumulated sediments or debris		As Required		
Control vegetated growth and woody vegetation		As Required		

**STORMWATER MANAGEMENT NARRATIVE  
(FRAMEWORK TAKEN FROM SECTION 12 OF SLODA APPLICATION CHECKLIST)**

Appendix A Post Construction Stormwater Inspection and Maintenance Log

March 20, 2018

Roxbury Wind Project				
Stormwater Management System Inspection & Maintenance Log				
	Schedule			
	As-needed Inspection	Maintenance	Inspector Initials and Date	Inspector Comments
Repair any erosion of the swale lining		As Required		
Mow vegetated swales		Annually		
Remove woody vegetation growing through riprap		As Required		
Repair any slumping side slopes		As Required		
Replace riprap where underlying filter fabric is showing or where stones have dislodged		As Required		
Culverts:				
Inspect culvert inlet, outlet, and structure	X			
Remove accumulated sediment and debris at the inlet, at the outlet, and within the conduit		As Required		
Repair any erosion at the culvert's inlet and outlet		As Required		

**STORMWATER MANAGEMENT NARRATIVE  
(FRAMEWORK TAKEN FROM SECTION 12 OF SLODA APPLICATION CHECKLIST)**

Appendix A Post Construction Stormwater Inspection and Maintenance Log

March 20, 2018

Roxbury Wind Project				
Stormwater Management System Inspection & Maintenance Log				
	Schedule			
	As-needed Inspection	Maintenance	Inspector Initials and Date	Inspector Comments
Inspect access road surfaces and shoulders for erosion, false ditches, and excess accumulation of sand that could impede water flow				
Remove excess sand either manually or with a front-end loader		As Required		
Grade gravel roads and shoulders		As Required		
Water Quality Treatment Buffer:				
Inspect treatment buffers for evidence of erosion or concentrated flow	X			
Inspect and repair down slope of all spreaders for erosion	X	As Required		
Repair, reseed areas of erosion or damaged vegetation in the buffers		As Required		



**STORMWATER MANAGEMENT NARRATIVE  
(FRAMEWORK TAKEN FROM SECTION 12 OF SLODA APPLICATION CHECKLIST)**

Appendix A Post Construction Stormwater Inspection and Maintenance Log

March 20, 2018

Roxbury Wind Project				
Stormwater Management System Inspection & Maintenance Log				
	Schedule			
	As-needed Inspection	Maintenance	Inspector Initials and Date	Inspector Comments
Maintenance Needed and When:				

**1-C**

**Site Control Documentation**



*MEMORANDUM OF LEASE*

*THIS MEMORANDUM OF LEASE* is executed for the purposes of recording in the Oxford County Registry of Deeds and affects a Lease dated September 5, 2012 and Addendum to Lease dated February 28<sup>th</sup>, 2015, between **LINKLETTER TIMBERLANDS, LLC**, a Maine limited liability company with its principal office in Athens, Maine (hereinafter referred to as "LESSOR"), and **MAINE DISTRIBUTED POWER, LLC**, a Maine limited liability company with its principal office in Portland, Maine (hereinafter referred to as "LESSEE").

LESSOR has leased to LESSEE and LESSEE has leased from LESSOR certain property for the purposes described in the Lease, including the right to use and develop that portion of the Property preliminarily depicted on the map attached hereto as Exhibit B for the purposes described in the Lease located in the Town of Roxbury, County of Oxford, State of Maine, and described in the attached Exhibit A recorded in the Oxford County Registry of Deeds in Book 3640 at Page 226.

TERM OF LEASE. The Lease shall become effective on the Effective date and will remain in effect until the twenty-fifth (25<sup>th</sup>) anniversary of the Project COD and commenced on September 5, 2012. The Lessee shall have the option to renew the Lease for one additional twenty (20) year term.

SALE OR DIVISION OF PROPERTY: During the term of the Lease, Lessor shall neither sell any portion of the Property, nor divide the Property by any other means constituting a "division" pursuant to the subdivision laws of the State of Maine, [the rules and standards of the Maine Land Use Commission,] the ordinances of the municipality where the Property is located or any other applicable statute, law, ordinance, by-law or rule, without the prior written consent of Lessee in each instance. Should the Lessor, at any time during the term of the Lease, decide to sell all or any part of the Property to a purchaser other than the Lessee, such sale shall be under and subject to the Lease and the Lessee's rights under the Lease.

NON-INTERFERENCE: The primary purpose for which the Premises have been leased is for a wind power project, including but not limited to designing, constructing, maintaining and operating wind turbine generators and towers and related equipment, including anemometry equipment, facilities, infrastructure and substructures, including electrical energy measuring and related equipment ("WTGs"), towers, transmission and interconnection facilities and uses incidental thereto and all necessary appurtenances and the installation of anemometers. Lessee shall have the exclusive right to convert all of the wind resources on the Property. Lessor's activities and any grant of rights Lessor makes to any third party, whether located on the Property or elsewhere, shall not, now or in the future, interfere in any way with Lessee's exercise of any rights granted under the Lease. Lessor shall not interfere with the wind speed or wind direction over the Property that might cause a decrease in the output or efficiency of any WTG, including any WTG located on land adjoining the Property. Lessor must consult with and obtain Lessee's prior written approval as to the location of all structures measuring in height greater than one quarter of the WTG tower height, and within a radius of 20 rotor diameters from any WTG, whether located on or off the Property.

The above Memorandum is executed for the purposes of recording only and is not meant to alter or amend the Lease between the parties.

IN WITNESS WHEREOF, the parties have executed this Memorandum of Lease this 16 day of February, 2015.

WITNESS:

[Handwritten Signature]

LINKLETTER TIMBERLANDS, LLC

By: [Handwritten Signature]  
Robert Linkletter, Manager

[Handwritten Signature]

MAINE DISTRIBUTED POWER, LLC

By: [Handwritten Signature]  
Alec Jarvis, Manager

STATE OF MAINE

Somerset Ct., ss.

February 16, 2015

Personally appeared the above named ROBERT LINKLETTER in his capacity as Manager of LINKLETTER TIMBERLANDS, LLC and acknowledged the foregoing instrument to be his free act and deed in said capacity.

Before me,

[Handwritten Signature]  
Attorney at Law/Notary Public

Debra A. Linkletter  
My Commission Expires: 11/2/18



STATE OF MAINE

Cumberland ss.

February 16, 2015

Personally appeared the above named ALEC JARVIS in his capacity as Manager of MAINE DISTRIBUTED POWER, LLC and acknowledged the foregoing instrument to be his free act and deed in said capacity.

Before me,

[Handwritten Signature]  
Attorney at Law/Notary Public

ROBERT C. PATTON  
Notary Public, Maine  
My Commission Expires April 8, 2018





**EXHIBIT A**

Certain lots or parcels of land in the Town of Roxbury, County of Oxford, State of Maine, being more particularly bounded and described as follows:

In the deed from M. E. Hussey to Oxford Paper Company dated October 22, 1920 and recorded in Book 354, Page 465 as follows: Being lot numbered Three (3) in the Third Range of lots in said Roxbury and lot numbered Three (3) in the Fourth Range of lots in said Roxbury, containing two hundred (200) acres, be the same more or less, and

Also a certain parcel of land situated in Roxbury in said County of Oxford and being lot numbered two (2) in the Fourth Range of lots in said town of Roxbury. Said lot containing one hundred (100) acres, more or less.

Also conveying certain lots or parcels of land in said Roxbury bounded and described in the deed from Swain & Reed, Inc. to Oxford Paper Company dated December 12, 1955 and recorded in Book 559, Page 2 as follows: ..being all of Lot numbered One (1) in the Fifth (5<sup>th</sup>) Range of Lots and Lot numbered two (2) in the Fifth (5<sup>th</sup>) Range of Lots in said Roxbury, commonly known as the S.M. Locke premises or homestead<sup>2</sup>, subject to the easements, reservations and exceptions set forth in said deed, the description therein being incorporated by reference.

**EXCEPTING AND RESERVING** from Lot numbered one (1) in Range five (5) above named, the following piece or parcel of land, bounded and described as follows: Beginning at the Northwesterly corner of Lot numbered one (1) in Range five (5); thence running in an Easterly direction along said Lot line a distance of one thousand four hundred and forty-four (1,444) feet to a yellow birch tree; thence at right angles and running in a Southerly direction three hundred and thirty (330) feet; thence at right angles and running in a Westerly direction along an old wire fence nine hundred and twenty-four (924) feet; thence turning and running in a southwesterly course along an old wire fence one thousand four hundred and twenty-two (1,422) feet to a post on the town line between Roxbury and Rumford and at the southwesterly corner of Lot numbered one (1) in Range five (5); thence turning and running in a Northerly direction along the Westerly line of said Lot numbered One (1), Range five (5), one thousand six hundred and thirty-three (1,633) feet, more or less to the point of beginning.

ALSO, certain lots or parcels of land in said Roxbury being more particularly bounded and described in the deed from Charles P. Bartlett to Oxford Paper Company dated May 18, 1966 and recorded in Book 645, Page 421 as follows:

(a) Lots number three (3) and four (4) in the fifth (5<sup>th</sup>) range of lots in said town and lots numbered three (3) and four (4) in the sixth (6<sup>th</sup>) range of lots in said town, containing four hundred (400) acres, more or less.

EXCEPTING AND RESERVING from the aforesaid lots or parcels of land, described in the deed recorded in Book 645, Page 421, however, all of the pegmatite ore and all other minerals of every kind, which were previously conveyed by the Grantor to Dana G. Douglass, Jr. by deed dated December 1, 1950 and recorded in Oxford County Registry of Deeds, Book 509, Pages 94 and 95.

(b) Also another lot or parcel of land situated in the Town of Roxbury, County of Oxford and State of Maine, being Lot number two (2) in Range six (6) in said town and county, containing one hundred (100) acres, more or less.

(c) Also another certain lot or parcel of land situated in the Town of Roxbury, County of Oxford and State of Maine, being more particularly described as the northwesterly part of Lot number three (3) in the seventh (7<sup>th</sup>) range of lots in said Roxbury, containing fifty (50) acres, more or less, which premises are bounded on the south by land now or formerly of Melissa Burgess and now or formerly known as the C.L. Fox Farm; on the east by land now or formerly of A. F. Philbrick; on the north by land now or formerly of H. L. Mitchell and on the west by other land of the Grantor.

This conveyance is subject to an easement for power line purposes granted by the Grantor to the Central Maine Power Company August 11, 1961; the base line of which easement runs across and over Lot number four (4) in Range five (5), Lot number four (4) in Range six (6), and the portion of Lot number three (3) in Range seven (7) herein conveyed; for a more particular description of the aforesaid easement, reference is made hereby to the record thereof in Oxford County Registry of Deed, Book 603, Page 287.

Being a portion of the premises conveyed to Linkletter Timberlands, LLC by Bayroot, LLC in a Quitclaim Deed with Covenant dated December 6, 2004 and recorded in the Oxford County Registry of Deeds in Book 3640, Pages 226 - 231.



**MEMORANDUM  
of  
ASSIGNMENT of LEASE**

THIS MEMORANDUM OF ASSIGNMENT OF LEASE is executed for the purposes of recording in the Oxford County Registry of Deeds and affects a Lease dated September 5, 2012 and Addendum to Lease dated February 16, 2015, between LINKLETTER TIMBERLANDS, LLC ("LESSOR") and MAINE DISTRIBUTED POWER, LLC ("LESSEE"), on certain property located on Horseshoe Valley Road, in the Town of Roxbury, County of Oxford and State of Maine, and as further referenced in a Memorandum of Lease recorded in the Oxford County Registry of Deeds at Book 5219, Page 54, and as described in the attached Exhibit A.

By Assignment and Assumption Agreement dated February 18, 2016, MAINE DISTRIBUTED POWER, LLC assigned all its right, title and interest under said Lease to HORSESHOE VALLEY WIND LLC, a Maine limited liability company.

By Agreement dated March 16, 2017, HORSESHOE VALLEY WIND LLC assigned all its right, title and interest under said Lease to ROX WIND LLC, a Massachusetts limited liability company with its principal place of business in Cohasset, Massachusetts.

The above Memorandum is executed for the purposes of recording only and is not meant to alter or amend the Lease between the parties.

IN WITNESS WHEREOF, this Memorandum of Lease has been executed this 11 day of January, 2018.

WITNESS:

Maine Distributed Power, LLC,  
By: Horseshoe Valley Wind LLC, Manager

By:   
John Richardson, Manager

Horseshoe Valley Wind LLC

By:   
John Richardson, Manager

Rox Wind LLC  
By: Palmer Management Corporation



By:   
Gordon Deane, President



State of Maine  
Sagadahoc, ss.

January 11, 2018

Personally appeared the above named John Richardson, Manager of Horseshoe Valley Wind, LLC and acknowledged the foregoing instrument to be his free act and deed in his said capacity.

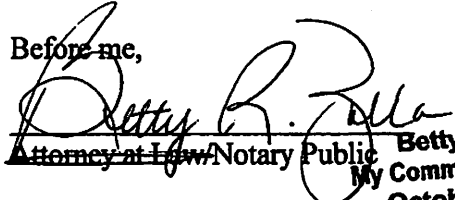
Before me,  
  
~~Attorney at Law~~ Notary Public Betty R. Zolla  
My Commission Expires  
October 5, 2018

State of Massachusetts  
NORFOLK, ss.

January 16, 2018

Personally appeared the above named Gordon Deane, President of Palmer Management Corporation, and acknowledged the foregoing instrument to be his free act and deed in his said capacity.

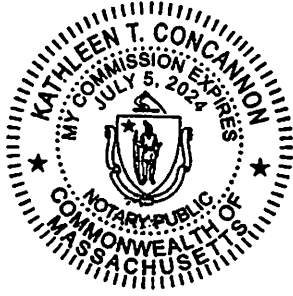

Before me,  
  
~~Attorney at Law~~ Notary Public



**Section 2**  
**Noise**